

ECE 445  
SENIOR DESIGN LABORATORY  
DESIGN DOCUMENT

---

# Particle Image Velocimetry

---

**Team #8**

HANFEI YAO (hanfeiy3@illinois.edu)  
YIHUI CHEN (yuhuic3@illinois.edu)  
YUEMING YUAN (yy28@illinois.edu)  
SIYUAN QIAN (siyuanq4@illinois.edu)

Sponsor: Timothy Lee

TA: Lijin Ma

March 26, 2024

# Contents

- 1 Introduction 1**
  - 1.1 Problem . . . . . 1
  - 1.2 Solution . . . . . 1
  - 1.3 Visual Aid . . . . . 2
  - 1.4 High-level requirements list . . . . . 2
  
- 2 Design 3**
  - 2.1 Block Diagram . . . . . 3
  - 2.2 Physical Design . . . . . 4
  - 2.3 Flowing System . . . . . 5
    - 2.3.1 Description . . . . . 5
    - 2.3.2 Requirements and Verification . . . . . 5
  - 2.4 Illumination System . . . . . 6
    - 2.4.1 Description . . . . . 6
    - 2.4.2 Requirements and Verification . . . . . 6
  - 2.5 Image Acquisition System . . . . . 6
    - 2.5.1 Description . . . . . 6
    - 2.5.2 Requirements and Verification . . . . . 6
  - 2.6 Interactive User Interface . . . . . 7
    - 2.6.1 Description . . . . . 7
    - 2.6.2 Requirements and Verification . . . . . 7
  - 2.7 Data Visualization System . . . . . 8
    - 2.7.1 Description . . . . . 8
    - 2.7.2 Requirements and Verification . . . . . 8
  - 2.8 Tolerance Analysis . . . . . 9
  
- 3 Cost and Schedule 10**
  - 3.1 Cost . . . . . 10
  - 3.2 Schedule . . . . . 11
  
- 4 Ethics and Safety 13**
  - 4.1 Ethics . . . . . 13
  - 4.2 Safety . . . . . 13
  
- References 15**

# 1 Introduction

## 1.1 Problem

Understanding how fluids move is crucial for many scientific and engineering applications. Nowadays, Particle Image Velocimetry (PIV) has evolved to be the dominant method for velocimetry in experimental fluid mechanics and has contributed to many advances in our understanding of turbulent and complex flows. However, we found out that the PIV equipment for experimental use was not straightforward enough for lower-grade students to understand the basic principle, also it had some restrictions on the environment and a relatively high cost. As a result, we plan to design a low-cost, easy-maintaining, and portable device that can demonstrate how PIV works in a simple way without many restrictions on the environment. We also add some interactive functions so it can give a deep impression on students and raise their interest in fluid dynamic study.

## 1.2 Solution

We propose to develop a device that can detect the state of particle motion in a flowing channel and present it in an intuitive way. Our design includes some distinct subsystems to realize relatively accurate and real-time measurements. Within the design, the Flowing Channel Subsystem ensures continuous air circulation through a sophisticated channel system driven by a blower and we plan to use small and light particles like styrofoam to be the tracer particles. The Laser and Optical Subsystem incorporates an adjustable laser source and optical components, such as lenses and mirrors, to illuminate a certain area in the flowing channel, in order to gain clear images of particles. The Image Acquisition Subsystem, equipped with a digital camera, captures and aligns particle images, forwarding them to an Image Processing System for precise velocity calculations, data analysis, and data visualization. The User Interface and Data Visualization Subsystem offers a user-friendly platform with a display for real-time fluid images and velocity field visualizations, enabling efficient monitoring and analysis of fluid dynamics. This holistic solution caters to applications demanding accurate and timely fluid velocity information without duplicating details from the specified components. Our PIV device also can provide some fun parts to help them understand how it works and raise their interest in fluid dynamics.

### 1.3 Visual Aid

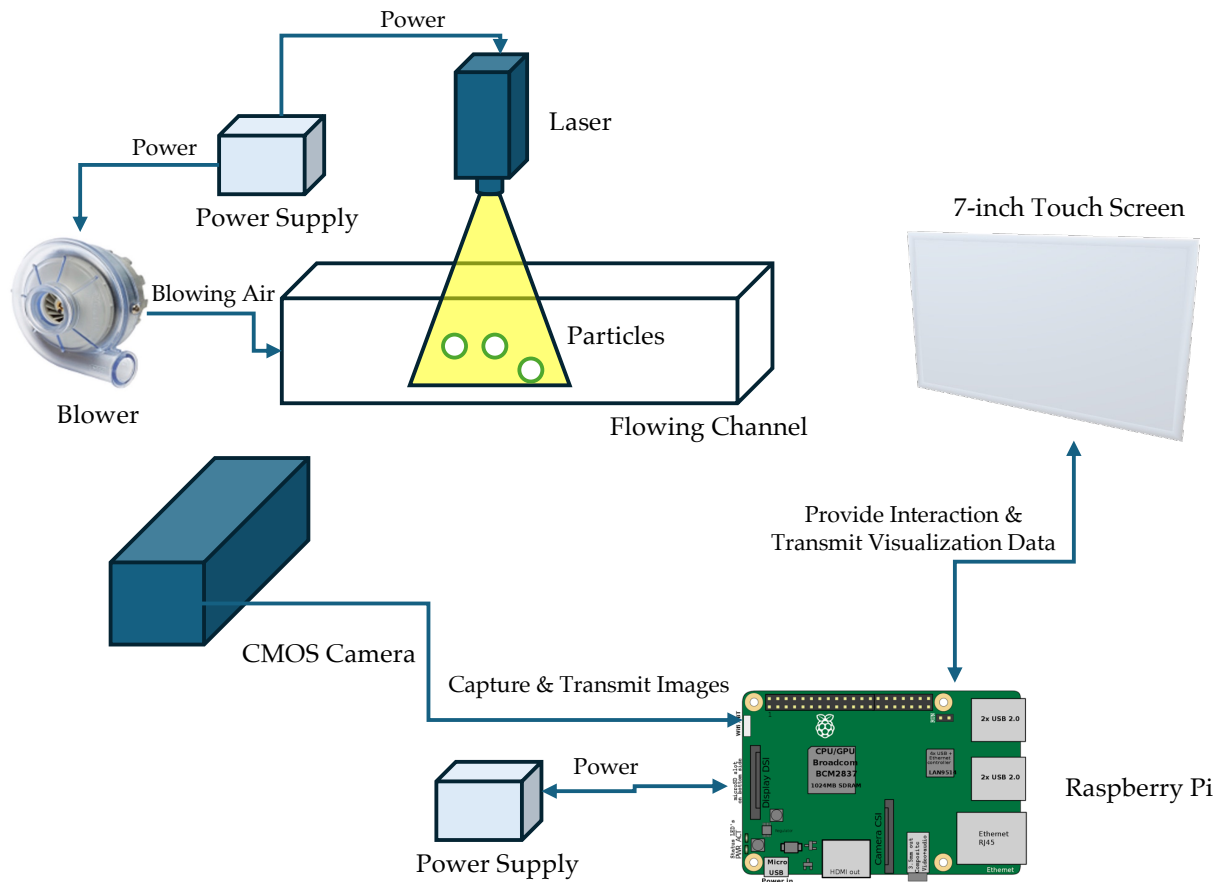

Figure 1: Visual Aid

### 1.4 High-level requirements list

- The system needs to be able to estimate the velocity magnitude and direction of the particles when estimating the particles, and we would like the velocity magnitude to be within 20% error and the angular deviation to be within 20 degrees when comparing the results of our measurements with the professional results.
- The system should offer an interactive experience with a user-friendly interface that includes real-time visualizations, e.g., particle images, particle velocities, and calculated flow rate of fluids.
- The instructor can control the device manually and demonstrate how the PIV device works directly or choose to control the device like how the users do. Under the instruction and supervision, students should be able to control the PIV demonstration, e.g., toggling on or off the measurement and changing the flow rate of fluids, with a real-time graphical user interface (GUI).

## 2 Design

### 2.1 Block Diagram

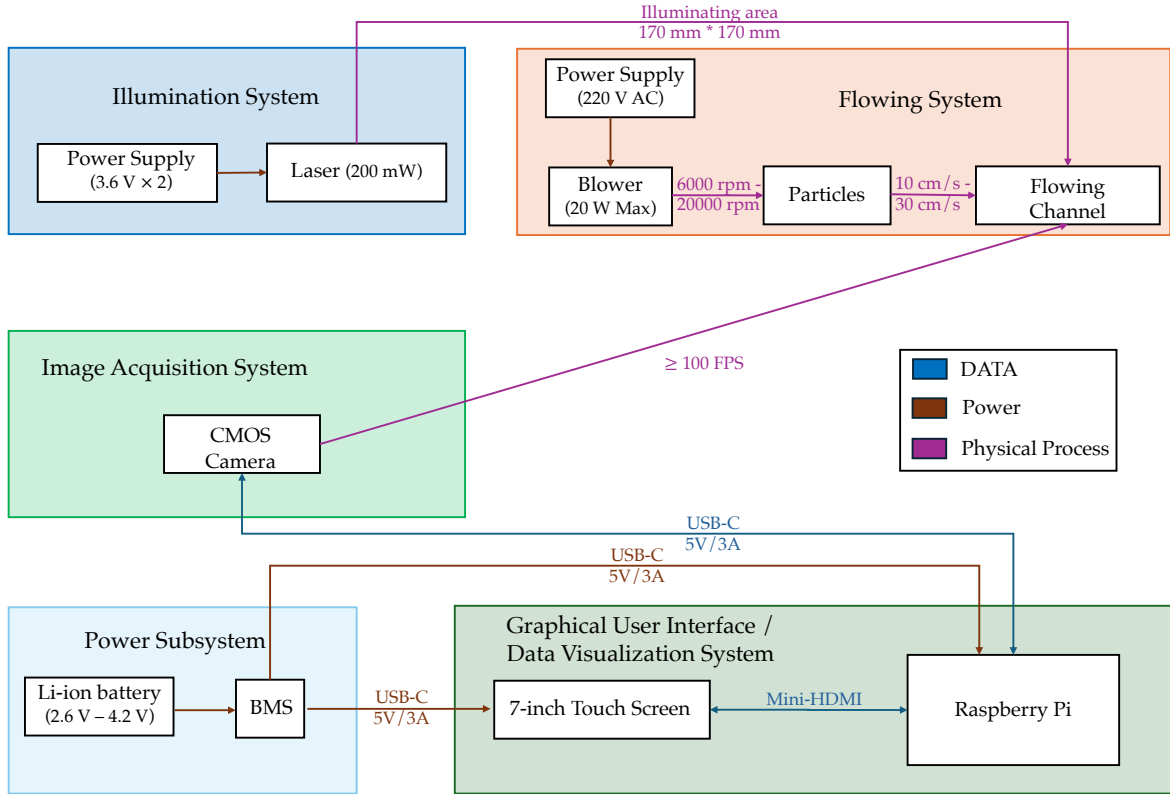

Figure 2: Block Diagram

To address the high-level requirements, we propose the high-level design shown in Fig. 2. We use double pulsed laser and a CMOS camera to perform accurate estimation of fluid velocity. We provide user-friendly instantaneous visual feedback on particle images, velocities, and calculated flow rates on a 7-inch touchscreen driven by a Raspberry Pi. Our design offers the flexibility to fine-tune a variety of parameters that directly impact the measurement of fluid flow rates, which helps illustrate the principles of fluid dynamics in a hands-on experience.

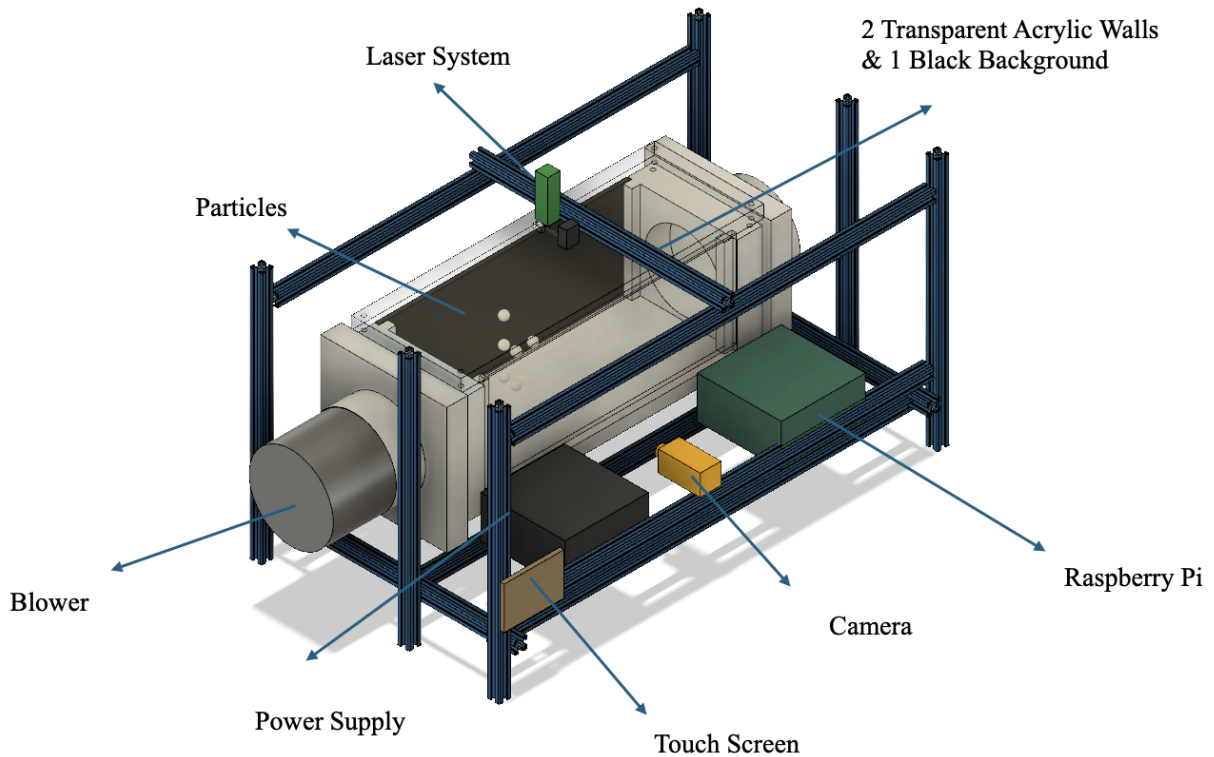

Figure 3: Design Overview

## 2.2 Physical Design

In this section, we will describe the Design Overview as shown in Figure 3. our design consists of the following parts, the gray pipe in the figure is our flowing system, its body is a closed pipe, it is connected to a blower with a maximum power of 20 W at one end, and the body of the pipe is covered by three transparent acrylic panels in the front, back and top to ensure light transmission, considering the assembly problem, we designed some structures for assembly. The front and top of the channel are covered by two transparent acrylic panels to ensure light transmission, the background is a black board, and considering the assembly problem, we have designed some structures for assembly. On the outside of the tube is a mechanical support structure made of aluminum profiles, the black box is a power supply, capable of providing 220 V power, and the yellow one is a high-speed camera, with an accuracy of more than 200 fps, attached to the aluminum profiles by means of a support piece. The green box is a Raspberry Pi, also attached to the aluminum profile through a support, and the Laser System on top contains a Laser Pointer and a lens to achieve the effect of presenting a Laser Sheet, which are also attached to the aluminum profile through a support.

## 2.3 Flowing System

### 2.3.1 Description

Transparent container that allows fluid to flow through. The container we intend to use is a hollow acrylic cylinder.

There is a manually operated 20 W Max blower that ensures that the air and particles can circulate through the flowing channel. We can measure and control the flow rate of the air. We put the particles in the flowing channel before we turn on the blower. The Flowing System must ensure that a relatively closed environment that other air disturbances in the environment will not affect the flow. In the system, the particles can flow at a speed of 10 cm/s - 30 cm/s.

For the particle selection, Jingsong [1] has provided some standards: particles should have a close to sphere shape in order to give a homogeneous image at any orientation. Particles should also be distributed evenly in the field so that the same accuracy can be obtained throughout the whole image area. This also guarantees that the two correlated images will not see a dramatic change in particle density. Such a sudden change in image density can introduce a large number of unmatched image pairs, and hence, introduce measurement "noise" to the result. So the shape should be as round as possible and the size distribution should be as uniform as possible and there should be a sufficiently high light scattering efficiency. Also, the tracer particles can should have a volume fraction of less than  $10^6$  [2] in order to eliminate the effect it would bring to the flow.

So the material we intend to use is styrofoam balls, the main advantage of this material is its strength, durability and lightweight properties, and under the action of the blower, this small ball can move through the pipe relatively easily.

### 2.3.2 Requirements and Verification

Requirements	Verification
1.The particles can flow at a speed of 10 cm/s - 30 cm/s	1.We can use a high-speed camera to take successive pictures of the ball in motion so that we can calculate the instantaneous speed of the ball and thus determine whether the ball speed can reach the required speed.
2.The inner space of the channel is closed and the small ball will not be blown out.	2.Turn on the blower continuously for a few minutes and observe if any of the small balls are blown out of the channel.
3.The channel should have 15 cm in diameter and 1 m in length.	3.First, the dimensions are determined in the modeling software, and second, the actual dimensions are determined using precision measuring equipment such as vernier calipers.

## 2.4 Illumination System

### 2.4.1 Description

A laser source that provides a laser beam for illuminating particles in the fluid and ensures that the laser source is position adjustable. And contains an optical system including lenses, mirrors, and filters for creating a clear spot and image. The laser needs a power of 200 mW and uses two 3.6 V rechargeable batteries to provide power.

### 2.4.2 Requirements and Verification

Requirements	Verification
Synchronize with the illumination system	Check whether the input image is clear enough to do the data visualization.
Illuminate the flowing channel and particles well	Open the blower and turn on the laser, check whether the we can see the particles in the output of the camera.

## 2.5 Image Acquisition System

### 2.5.1 Description

A camera is used to capture images of the particles in the fluid, sending the captured pictures to an image processing system, which, is used to calculate the particle velocity. At the same time the camera makes sure to align the particles in the fluid channel. The camera should have high spatial resolution, high sensitivity, short and accurate inter-frame time, and sometimes high frame rates. The frame rate of the Camera should be not lower than 100 fps. The camera needs 5 V / 3 A power input via USB-C cable and transmit information via USB 2.0 cable.

### 2.5.2 Requirements and Verification

Requirements	Verification
High resolution and high frame rate	Record input images file size or detailed information in computer, it should have around 190 fps at the resolution of 1280*1024 or 270 fps at the resolution of 1280 * 720.
Synchronize with the illumination system	Check whether the input image is clear enough to do the data visualization.



Work well with Raspberry Pi	Connect to the Raspberry Pi and check whether it can deal with the input of the camera and do the data visualization and give a result to the GUI surface.
-----------------------------	--

## 2.6 Interactive User Interface

### 2.6.1 Description

The Interactive User Interface features a 7-inch touchscreen that presents customized GUI software for an enhanced user experience. The GUI software is pivotal in translating user interactions into actionable commands for software backend and offering visual feedback to the user. The GUI is tailored to real-time PIV control and monitoring, which is essential for communicating information to the user and enabling precise fine-tuning of system operations.

Power supply for hardware components in this subsystem comes through a 5V/3A USB-C connection, sourced from the Power Subsystem. The power supply ensures that the screen and the Raspberry Pi can maintain the responsiveness and reliability of the GUI.

The GUI software is designed to provide users with comprehensive control over the PIV functions. Through the GUI, users can initiate and terminate the image acquisition and data visualization processes and conveniently adjust the parameters [3] of the CMOS camera, such as contrast and brightness, which might directly impact the accuracy of fluid velocity estimation. The objectives of the GUI software focus on enabling on-the-fly adjustments to the system, ensuring that users can conveniently interact with the PIV system.

The Raspberry Pi outputs to the touchscreen via a mini-HDMI connection, which supports the display of high-resolution (1024 × 600) graphics and ensures that the visual output is clear and vibrant.

Our choice of a 7-inch touchscreen is a balance between an adequate display size for user interaction and the system portability. A 7-inch touchscreen operates efficiently with minimal power consumption, which contributes to the overall energy efficiency of the system. Furthermore, a 7-inch touchscreen fits well within our budget constraints without substantially sacrificing display quality or system functionality. We select the Raspberry Pi for its capability of running substantial GUI and computational software, its sufficient community support and availability of development tools, and its compact size which makes it an ideal component of a PIV system. A Raspberry Pi is also affordable and widely available.

### 2.6.2 Requirements and Verification

Requirements	Verification
--------------	--------------

GUI response must appear on the touchscreen within 50 ms after the user input is received at the device driver level.	Measure input response time using a software timer from the moment of touch to the action being reflected on the GUI.
GUI software must have an error rate of less than 0.1% for command execution.	Use a test script to execute a large number of commands and track the success rate over the total number executed.
GUI must allow users to navigate to any primary function within 3 clicks from the home screen.	Conduct a test where users are observed navigating to different functionalities from the home screen. Record the number of clicks and verify that the primary functionalities are accessible within 3 clicks.

## 2.7 Data Visualization System

### 2.7.1 Description

The system first processes the images and calculates basic information, including the velocity magnitude and the angular deviation. The captured images of the particles are transferred to the Raspberry Pi for further processing and visualization. Here, we use Python to do the image processing and use the library OpenPIV to calculate PIV.

We will also provide multiple visualizations of the calculated PIV. The basic figure, static visualization, will show the velocity vectors in different parts of the fluid. For better illustration, we will use gradient colors to display the velocity more intuitively. We will also provide an dynamic visualization. Combining the data measured in successive images, the system will generate a video of about 20 - 30 fps to show the dynamic variations.

These visualizations will also be done in Python on Raspberry Pi, and will be shown on the touch screen to interact with.

### 2.7.2 Requirements and Verification

Requirements	Verification
The error of calculated velocity magnitude at a single point is less than 20% and the angular deviation is less than 20 degrees compared with the designed one.	Compare the calculated result we get from the Python program on Raspberry Pi with the expected velocity we have in the flowing system.

The static visualization shows an accurate vector (as defined above) in more than 75% areas of the picture.	Compare the visualized vectors with the theoretical result.
The dynamic visualization displays the fluid within 3 seconds delays.	Test the visualization system for 30s, and compare the dynamic visualization and the recorded video of the actual fluid.

## 2.8 Tolerance Analysis

The velocity is calculated by the following formula:

$$V = \frac{\Delta X}{\Delta t}$$

$$\Delta X = \frac{D_p A}{R}$$

where  $\Delta t$  is the time interval between successive images.  $D_p$  is the average displacement of particles between successive images, measured in pixels;  $A$  is the size of the area being imaged;  $R$  is the resolution of the digital camera, measured in pixels.

The main error may come from the following sources: 1. Error in  $\Delta t$ . We require the digital camera to take successive photos in a short time. If it happens to have a delay in taking photos, the actual  $\Delta t$  will be different from the expected one. 2. Error in  $\Delta X$ . This error includes errors in measuring the displacement between the particles ( $D_p$ ) and the error in measuring the size of the imaged area ( $A$ ).

To achieve our expected precision of the measurements (within 20% error), we need to ensure:

1. The inter-frame time accuracy of the camera. Assume the displacement measurement is accurate and we use a camera of 60 fps, namely  $\Delta t = \frac{1}{60} \approx 0.01667$ s. The tolerated inter-frame time interval is between  $\frac{1}{1 \pm 0.2} \Delta t \approx 0.01389$  s – 0.02083 s.
2. The accuracy of the displacement measurement. Assume we use a camera of 60 fps and its inter-frame time is exactly 0.01667 s. We consider two cases here, the minimal estimated velocity 10 cm/s and the maximum estimated velocity 30 cm/s. When the velocity is 10 cm/s, we need to ensure  $\Delta X < 0.2 * V * \Delta t = 0.0333$  cm in two successive photos. Similarly, when the velocity is 30 cm/s, we need to ensure  $\Delta X < 0.1$  cm.

### 3 Cost and Schedule

#### 3.1 Cost

We assume that each person in our group works at least 10 hours a week on our project. Given that a Graduate Research Assistant at UIUC typically earns around \$40 per working hour, the total labor cost for our team will be

$$4 \times 40 \times 10 \times 10 \times 2.5 = \$40000$$

<b>Parts</b>	<b>Manufacturer</b>	<b>Cost</b>
Labor Cost		¥ 289136
Camera	Zhonganweishi	¥ 898
Styrofoam Balls	Xinkang Industry	¥ 14
Laser	Qilan	¥ 99
Aluminum profiles and fittings	Zhongda Aluminum Industry	¥ 125
Power Supply	Shanke	¥ 220
Blower	Yizhan firefight Industry	¥ 120
Touch Screen	Makebit	¥ 189
Raspberry Pi Package	Raspberry Pi Foundation	¥ 408
<b>Total</b>		<b>¥ 291209</b>

### 3.2 Schedule

Week	Hanfei Yao	Yihui Chen	Yueming Yuan	Siyuan Qian
3/18-3/24	Explore mechanical algorithms for PIV system	Check the simple and low-cost implementation of PIV	Explore the image processing and OpenPIV usage	Explore low-cost single-board computer and touchscreen options
3/25-3/31	Build a small model to test different particles	Selection for our camera and laser	Write Python script for the basic components and test on laptop	Consider GUI functionalities and order Raspberry Pi and touchscreen
4/1-4/7	Build and test the overall simple model	Basic function testing with the particles and phone camera	Install required software on Raspberry Pi and do unit tests on Raspberry Pi	Initialize Raspberry Pi OS and test touchscreen integration
4/8-4/14	Build and test the optic system with Yihui	Test and adjust the laser and camera	Implement the static visualization	Implement and test basic functionalities of the GUI
4/15-4/21	Build parts for the real mechanical system	Test and adjust the laser and camera improve the degree of synergy	Verify the static visualization and implement the dynamic visualization	Implement GUI functionality for user fine-tuning of the CMOS camera
4/22-4/28	Assemble the parts and test the whole system	Assemble the system, improve image quality physically by adjust the mechanical design	Complete the implementations and add GUI control	Perform final software adjustments and test functionalities on the touchscreen with Yueming
4/29-5/5	Test the whole system	Test the whole system	Test the whole system	Test the whole system
5/6-5/12	Prepare for the demo	Prepare for the demo	Prepare for the demo	Prepare for the demo

5/13-5/19	Prepare for the demo	Prepare for the demo	Prepare for the demo	Prepare for the demo
-----------	----------------------	----------------------	----------------------	----------------------

## 4 Ethics and Safety

In this project, we consider following ethics and safety concerns:

### 4.1 Ethics

- Privacy. The IEEE and ACM[4] codes also require engineers to respect the public's privacy. Since our design includes a voice control system, we need to ensure that the information we obtain will not be disclosed for other uses.
- Educational impact. Since our project will be applied to education, especially to demonstrate PIV to children, we need to ensure the system has a positive educational impact, reducing confusion and avoiding any harm to the users. For this reason, we plan to create materials that explain the principles of the PIV measurement and operation manual of the control system in an age-appropriate manner.

### 4.2 Safety

The IEEE[5] code emphasizes the importance of prioritizing safety and health in engineering project, "to hold paramount the safety, health, and welfare of the public." This is strongly relevant to the most of the system in our design.

- Laser Safety. Safety notes in the LD-PS/5[6] states that The laser must only be used when integrated into a system that does not allow laser radiation to exit the system. Any eye and skin exposure to the light must be strictly prevented. Never operate the device without the cylindrical divergent lens. Never point the laser beam at humans animals or flammable materials. Fire, serious injury, or death might result from this action. Never adjust the laser while it is turned on. Safety goggles are suggested for use while operating.
- PM Safety. When the blower is blowing air, it can carry some particulate matter. The United States Environmental Protection Agency[7] declares that Exposure to such particles can affect both your lungs and your heart. Numerous scientific studies have linked particle pollution exposure to a variety of problems, including: premature death in people with heart or lung disease; nonfatal heart attacks; irregular heartbeat; aggravated asthma; decreased lung function; increased respiratory symptoms, such as irritation of the airways, coughing or difficulty breathing. People with heart or lung diseases, children, and older adults are the most likely to be affected by particle pollution exposure.
- Blower Safety. The operating blower can work at a speed of 20000 RPM. The OSHA training[8] states that using a compressed air blower presents potential hazards that can do serious harm to the user, as well as to other people working in close proximity. Flying chips, dust, and particles can be sent flying through the air at a high rate of speed and strike someone, causing cuts and abrasions to their skin or an eye. And if a compressed air blower is activated when placed directly against or near the skin or other body parts of a person, the high-pressure stream of air can actually

pierce the person's skin, inject air or chemicals into their bloodstream, rupture an eardrum, or permanently damage an eyeball.



## References

- [1] J. Liu. "DEVELOPMENT AND ANALYSIS OF A LOW SPEED PARTICLE IMAGE VELOCIMETRY SYSTEM." (1998), [Online]. Available: [https://trace.tennessee.edu/cgi/viewcontent.cgi?article=11834&context=utk\\_gradthes](https://trace.tennessee.edu/cgi/viewcontent.cgi?article=11834&context=utk_gradthes) (visited on 03/06/2024).
- [2] R. Adrian. "particle imaging techniques for experimental fluid mechanics." (1991), [Online]. Available: <https://www.annualreviews.org/content/journals/10.1146/annurev.fl.23.010191.001401> (visited on 03/06/2024).
- [3] Raspberry Pi, *Plug and play raspberry pi usb webcam*, Accessed: 2024-03-27, 2023. [Online]. Available: <https://www.raspberrypi.com/tutorials/plug-and-play-raspberry-pi-usb-webcam/>.
- [4] ACM. "ACM Code of Ethics." (2018), [Online]. Available: <https://www.acm.org/code-of-ethics> (visited on 03/06/2024).
- [5] IEEE. "IEEE Code of Ethics." (2016), [Online]. Available: <https://www.ieee.org/about/corporate/governance/p7-8.html> (visited on 03/06/2024).
- [6] Optolution. "LD-PS/5: OEM laser module for Particle Image Velocimetry (PIV)." (None), [Online]. Available: [https://optolution.com/media/ld-ps\\_datasheet.pdf](https://optolution.com/media/ld-ps_datasheet.pdf) (visited on 03/06/2024).
- [7] U. S. E. P. Agency. "Particulate Matter (PM) Pollution." (2023), [Online]. Available: <https://www.epa.gov/pm-pollution/health-and-environmental-effects-particulate-matter-pm> (visited on 03/06/2024).
- [8] O. training. "Controlling Hazards Associated with Compressed Air Blowers." (2016), [Online]. Available: [https://oshatraining.com/wp-content/uploads/OSHA\\_Training\\_Toolbox\\_Talk\\_-\\_Controlling\\_Hazards\\_Associated\\_with\\_Compressed\\_Air\\_Blowers.pdf](https://oshatraining.com/wp-content/uploads/OSHA_Training_Toolbox_Talk_-_Controlling_Hazards_Associated_with_Compressed_Air_Blowers.pdf) (visited on 03/06/2024).