



3D model of a satellite footprint over the Earth

ECE 445 Senior Design Project

Design Document



Group members:

Zihua Gong

Lunan Ke

Wenhan Jiang

Kuangji Chen

Advisor: Prof. Pavel Loskot

27.03.2024

Contents

Contents	1
1 Introduction	2
1.1 Problem Statement	2
1.2 Solution Overview	2
1.3 Visual Aid	3
1.4 High-level requirements	3
2 Design	4
2.1 Design overview	4
2.2 Block Diagram	4
2.3 Subsystem Descriptions	5
2.4 Tolerance Analysis	12
3 Cost	14
3.1 Labor	14
3.2 Parts	14
3.3 Grand Total	14
4 Schedule	16
5 Ethics and Safety	18
5.1 Safety	18
5.2 Ethics	18
References	20

1 Introduction

1.1 Problem Statement

Educational institutions, aerospace enthusiasts, and researchers face a significant challenge in effectively visualizing and demonstrating the dynamic interactions between satellites and the Earth. While traditional models and computer simulations provide a foundational understanding, they often fall short of offering the physical interaction and direct observation components crucial for deepening engagement and comprehension. The inherent complexity of satellite dynamics requires a more immersive approach to education and demonstration.

For us adults, we can easily get access to knowledge of satellite orbitals either through formal papers or online media. However, even videos and animation, the most vivid ways of demonstration, could be too abstract for teenagers and kids, whose interest to science matters a lot.

Therefore, there is a pressing need for an accurate, hands-on representation of satellite operations in relation to the Earth. This solution should effectively illustrate critical aspects of a certain satellite orbit, such as orbit altitude adjustments, Earth rotation and the casting point from the satellite to the Earth. By bridging this educational gap, we can foster a deeper understanding of satellite technology, inspire the next generation of aerospace professionals, and support the continued innovation and growth within this vital sector.

1.2 Solution Overview

We propose to create a 3D hardware demonstrator that physically represents the interaction between a satellite and the Earth. This model will feature a stationary satellite (in x and y axis) with the capability to adjust its altitude along a one-dimensional axis(z). The Earth model, placed on a L-shape stand with gears and controlling circuits in it, will rotate, simulating the planet's rotation. This setup aims to offer a more intuitive understanding of satellite positioning, Earth's rotation, and their interplay, enhancing educational outcomes and interest in aerospace and earth sciences.

1.3 Visual Aid

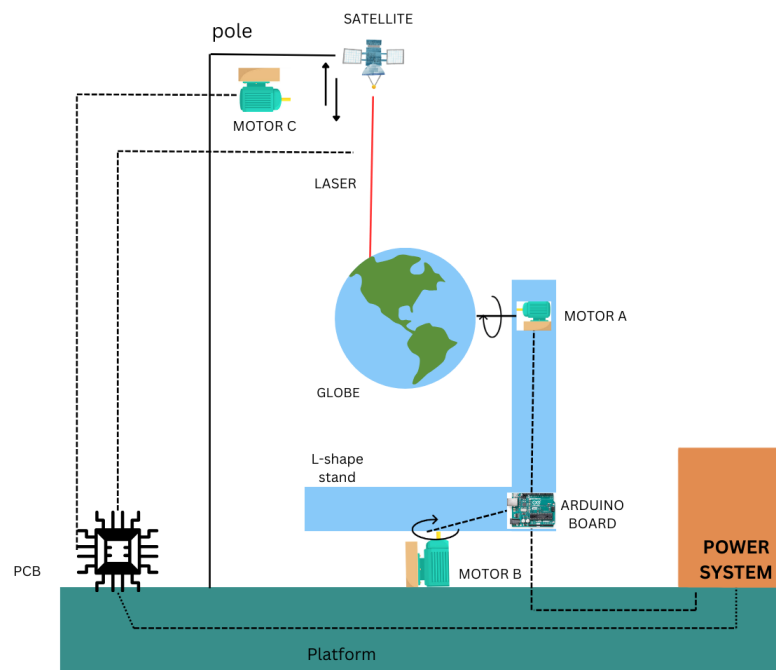

1.4 High-level requirements

- The globe we use will be of proper size so that it will not be too large for the motors to drive or too small for poor visualization, we set the standard of the globe of 30 cm (about 11.81 in) in diameter.
- To ensure the safety and endurance of work, we will use low-power laser and make the whole device as light as possible while keep it solid enough to avoid problems in rotation.
- Since the focus of our work is to demonstrate the satellite footprint, we must make sure that the footprint is correct. Therefore, the least accuracy of the position controlling of motors should be within 1.8 degrees, otherwise will result into a huge error in earth position.

2 Design

2.1 Design overview

In order to project a trajectory over a globe. We decide to fix the relative position of the satellite from the globe, while the globe itself can rotate in two dimensions to achieve the smooth movement of the satellite. Meanwhile, we will alter the distance between the satellite and the center of the globe to represent the change in altitude of the satellite trajectory. With an initial starting coordinate and a given trajectory, our circuit can turn it into a signal of motion to the motors to correctly represent the trajectory.

2.2 Block Diagram

2.2.1 System Overview

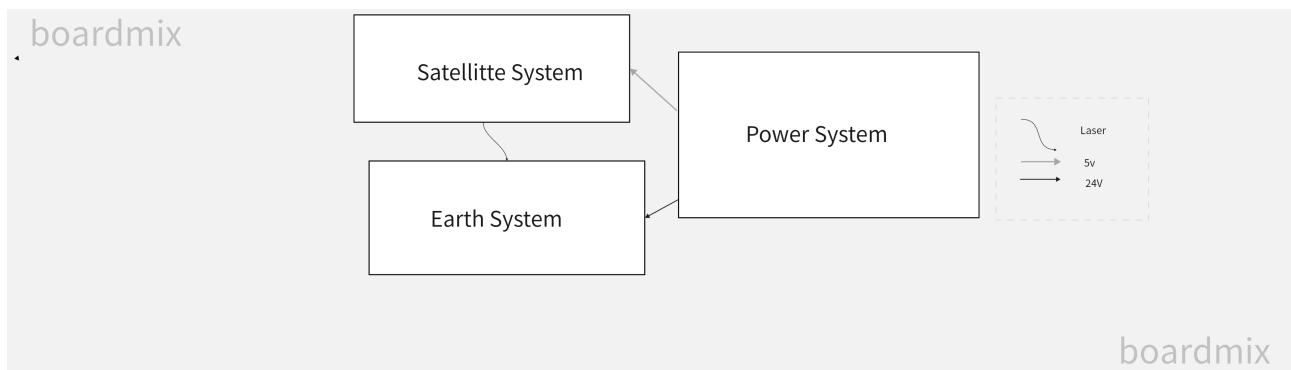

Figure 2.1: System Overview

2.2.2 Earth Subsystem

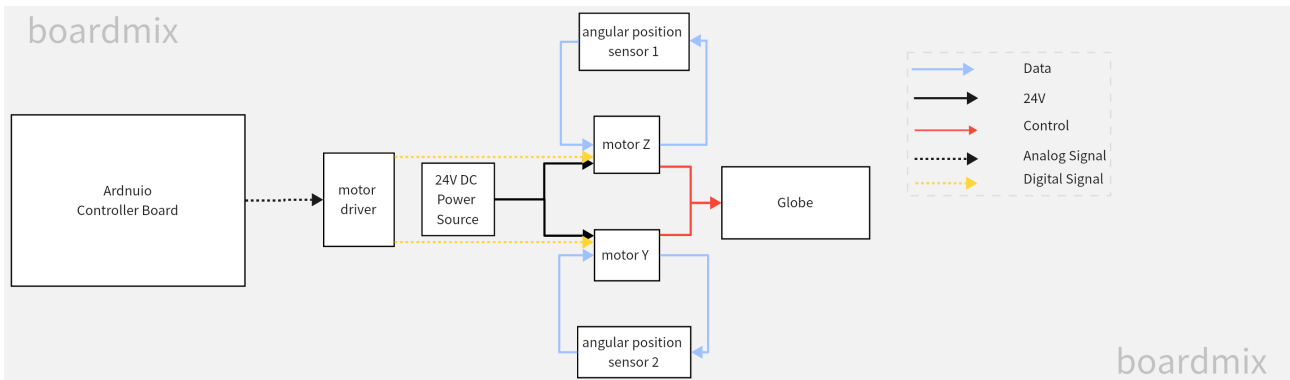

Figure 2.2: Earth Subsystem

2.2.3 Satellite Subsystem

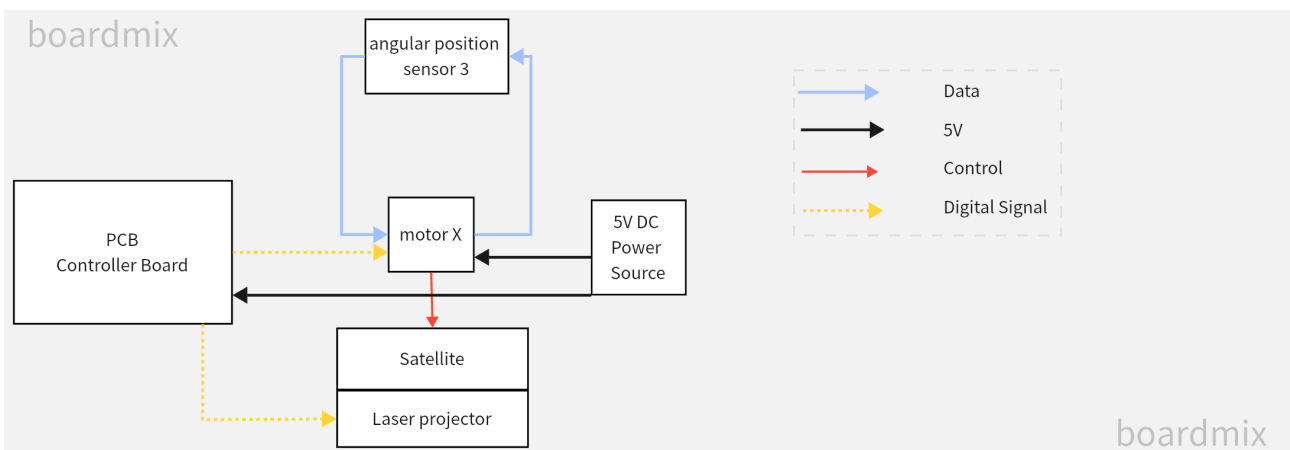

Figure 2.3: Satellite Subsystem

2.3 Subsystem Descriptions

2.3.1 Earth Subsystem

Input: digital signal from controlling board

Output: Motion of the globe

Components: Motor drivers that supports the motion of the corresponding motor, two motors X Y that control the 3-dimensional motion of the globe, two angular sensors that detects the angular position of the system.

3D model

To achieve the 2-dimensional motion of the globe surface, we adopt the designs shown below to manage it with two motors. In this case, two stepper motors, motor Z and motor Y can realize two canonical angular movements of the globe and further control the latitude and longitude change of the trajectory.

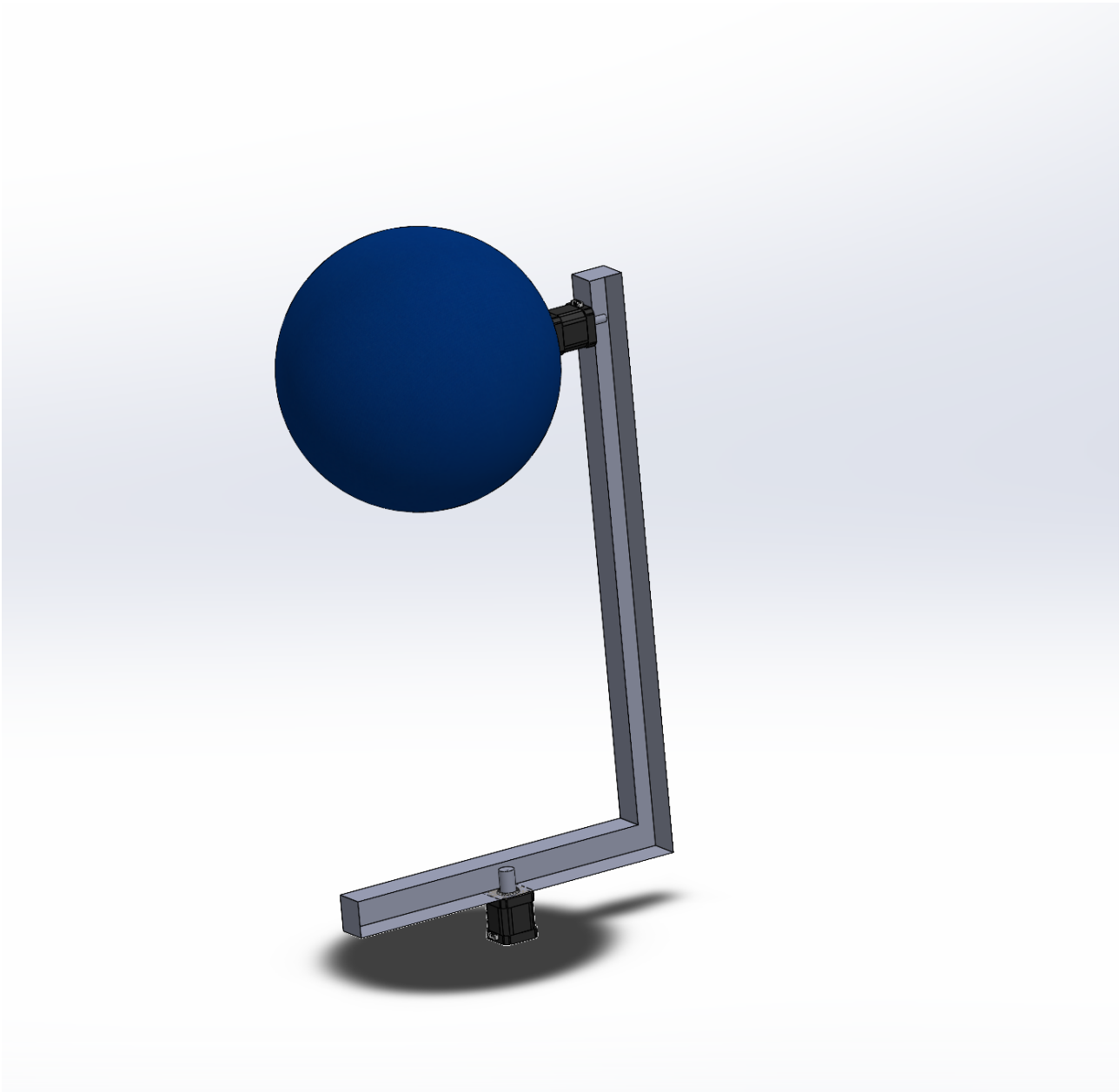

Figure 2.4: 3D-model of Earth Subsystem

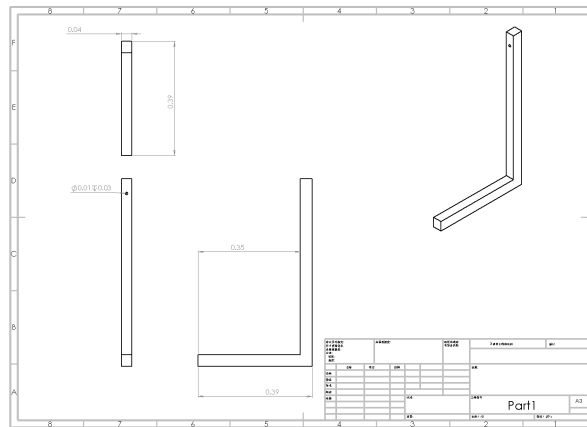

Figure 2.5: CAD for the L-shape stand

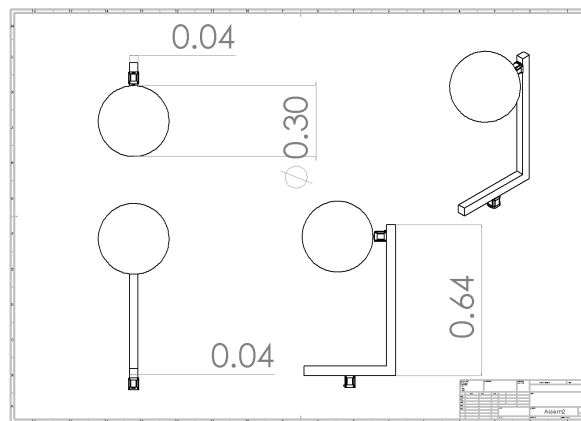

Figure 2.6: CAD for Earth Subsystem

Besides, we use two angular position sensors to detect the current state of the globe for accurate controlling. The stepper motors should be 42 stepper motors with 24 V DC power source and controlling by the LN298 motor drivers. The LN298 should be controlled by the Arduino. The least accuracy of the position controlling of motors should be within 1.8 degrees. Within such error, there will not be many differences between the one projected and the real one.

Requirements and Verification

Table 2.1: Requirements and Verifications

Requirements	Verifications
1. Motor drivers can successfully receive the control signal from the control board and turn it into a voltage signal that powers the motors.	1. We will design a test orbit and send its parameters to the controlling board. If the motion of the orbit performs differently from our design, then we need to adjust the motor structure or correct our algorithm.
2. Angular detect sensors can correctly measure the angular movement. In our design, we integrate it into the motor itself, together with the motor drive. The sensor will detect angular movement continuously and show it over the screen.	2. We will program a test signal in advance to verify the correctness of the sensor. We will run the same program for ten times to make sure that the sensor and reset function works well.
3. Motors can correctly perform the orbital movement of the satellite. This process requires the correct algorithm and the correct operation of motors.	3. We will first examine the basic structure of the motors and check whether its main structure is complete. Besides, by switching two motors and examining the difference of the shown orbit, it can reveal the potential individual differences between two motors, which can help us to adjust them.
4. The motors can correctly reset to initial state to perform next orbit. This function is integrated into the motor drive. Our motor drive can utilize the angular sensor to detect the current angular position to help it reset to initial state.	4. We will apply ten different orbits to our earth system and then send the reset signal to the motor drive. We will check the final state of the earth system whether it enforces the function correctly.

Table 2.1 continued from previous page

Requirements	Verifications
5. The error of the motors should be within 1.8 degrees.	5. We will utilize the internal self-calibrated function to calibrate the motor.

2.3.2 Controlling Board Subsystem

Input: orbital parameters, other function commands

Output: Control signals

Components: Arduino board, PCB board

Our control circuit will accept the initial coordinate and trajectory function as input. We will use an Arduino board to achieve the control system of the globe. For example, our circuit should turn the coordinate changes in the orbit into the angular movement of the motors. Controlling signal will be sent to the motor driver and then control the movement of the motors. The platform we choose here is Arduino as it can run C scripts, which can be quite beneficial for us to make programming. With this we can deal with the mathematical input correctly and effectively. The controlling board will take orbital parameters as its input. They include semi-major axis a , orbit eccentricity e , argument of perigee ω , right ascension of ascension node Ω , then we need to derive the derivative of the orbit in Cartesian coordinate system to obtain the relationship between two angular velocity input, which are further processed into digital signal and sent to motor drives. The relationship between coordinates is shown in table 2.2. Besides, we use introduce another PCB board to control the stepper motor that control the altitude and the laser projector.

Table 2.2: Requirements and Verifications

Requirements	Verifications
1. Our controlling board enforces the algorithm correctly and output the right signal.	1. We will design an algorithm to test our coordinate transform algorithm and control algorithm. For different part of the overall algorithm, we will develop different methods to test the different function. For coordinate transform part, we will monitor the output and compare it with the calculated result to show whether it is correct. For control part, we will monitor the signal output from PCB or Arduino board to check whether the function is correctly enforced.
2. PCB board can correctly control the laser projector and the stepper motor. Stepper motor can correctly control the altitude of the satellite.	2. A pre-calculated orbit will be applied to the control system and then transmitted to the stepper motor. We will then check whether the PCB part works well.
3. Other control command can be enforced successfully, including reset, shutdown and start signal.	3. We will perform them successively after programming to check whether they are correctly enforced.

2.3.3 Satellite Subsystem

Input: orbital parameters, other function commands

Output: Satellite Vertical Movements and Laser projection

Components: PCB board, Vertical Motor, Laser components

In our design, two dimensions of the satellite itself is fixed (its relative position to the globe center) and the only changing dimension is its altitude. We achieve this by adopting a vertical stepper motor and a position sensor. Given the changes in altitude from the given trajectory, the stepper motor can receive controlling signal from the control board and control the vertical movement of the satellite. Besides, we will use a laser to mark the movement of trajectory over the globe surface. The stepper motors should be 42 stepper motors with 24 V DC power source and controlling by the LN298 motor drivers. The LN298 should be controlled by the Arduino. The laser here we use should be a low-power one. Laser with higher power may lead to physical

injury in our eyes. Besides, the weight of satellite system should be less than 500g to ensure the motor can successfully control the movement of the satellite. Otherwise, there will be a high errors in the vertical movement of the satellite. Besides, a overweight structure may lead to instability in the system and cause other systemic problems.

Table 2.3: Requirements and Verifications

Requirements	Verifications
1. The satellite model can move vertically by the motor to indicates the real altitude of satellite over the earth surface and synchronize the earth movements.	1. Verify the satellite's vertical movement: Command the satellite to adjust its altitude, monitor actual altitude readings, and confirm synchronization with Earth's movements.
2. The laser components can project a laser point on the earth surface to indicates the real position of the satellite projection point.	2. Validate laser projection: Activate the laser components, observe the projected point on the Earth's surface, and ensure alignment with the satellite's actual position.
3. The PCB can realize point 1 and 2 successfully.	3. Confirm PCB integration: Send control commands to adjust altitude and activate laser projection via the PCB, monitoring system responses to ensure accurate functionality without errors.

2.3.4 Power Subsystem

Input: DC9V1A Power Cord, DC24V3A Power Units

Output: Arduino MEGA2560 R3, 57 Stepper Motor

We use one 5V DC power source to supply controlling board and one 24V DC power source to supply the motors. 5V and 24V is the standard input requirement of the Arduino board and motors. Any power source providing different voltage supplies may lead to malfunction of the system.

The power requirements for all the components from the device are shown below:

Devices	Voltage/Current Requirements
Arduino MEGA2560 R3	VIN: 6-20V input to the board. MAXIMUM current per I/O: 20mA MAXIMUM current per +3.3V: 50mA
57 Stepper Motor	2.4A, 24V DC

Figure 2.7: Power Subsystem requirements

To support the devices, we purchased one DC9V1A power cord and two DC24V3A power units.

Table 2.4: Requirements and Verifications

Requirements	Verifications
1. The three motors should be powered by DC24V3A power units, which should guarantee the capability of motors to rotate the globe and the module.	1.If the globe can be driven to rotate with correct and accurate angle and speed as we want, the power supply for motors is qualified.
2. The Arduino should hold enough ports for three motors to be controlled regarding the angle and speed.	2.Three motors can share the GND and 5V ports in Arduino, while three digital ports are needed for each motor. One Arduino holds 16 digital ports, which should be enough for monitoring the motors.
3. The Arduino should be powered by an independent DC9V1A power cord.	3. Arduino is working well with a DC9V1A power supply to provide a 5V output voltage for the driven parts of motors.

2.4 Tolerance Analysis

2.4.1 Motor Drivers and Voltage Tolerance

Tolerance for Control Signal

If the control signal from the board has a standard deviation (σ) due to noise or other factors, calculate how this affects the voltage output of the motor drivers. For example, if $\sigma_{control} = 0.1V$ and the driver amplifies by a factor of 2, then $\sigma_{output} = 2 * \sigma_{control} = 0.2V$.

Voltage Output Range

Assuming the motor requires $24V \pm 10\%$, the acceptable range is 21.6V to 26.4V. Evaluate if the driver's output falls within this range under all conditions.

2.4.2 Angular Detection Sensors

Sensor Accuracy and Precision

Define the maximum allowable error (e.g., ± 0.9 degrees) to stay within the 1.8 degrees system tolerance. If the sensor has a standard deviation σ_{sensor} , ensure that $3\sigma_{sensor}$ (covering 99.7 % of cases) is less than or equal to this error.

Impact of Error on System Performance

Calculate the impact of sensor error on the globe's positioning. For example, if the globe's circumference is 100 units, a 0.9-degree error translates to $0.9/360 * \text{circumference} = \text{misalignment}$.

2.4.3 Stepper Motors

Step Angle and Accuracy

For a 42-type stepper motor, if the step angle is 1.8 degrees, one step corresponds to this angle. Assess the impact of missing or inaccurately executing a step. If the tolerance is $\pm 5\%$ per step, the actual step might vary between 1.71 to 1.89 degrees.

Cumulative Error

For a sequence of n steps, calculate the maximum cumulative error. Assuming independence, the total error could be $\sqrt{n} * \text{step}_{error}$ at most.

2.4.4 System Integration

Cumulative System Error

Combine errors from all components. If they're independent, total error $\sigma_{total} = \sqrt{\sigma_{motor}^2 + \sigma_{sensor}^2 + \sigma_{driver}^2}$. Ensure that this combined error does not exceed the system's tolerance.

Worst-Case Scenario

Evaluate the system's performance under the worst-case scenario, where all components perform at their maximum error limits simultaneously.

3 Cost

3.1 Labor

Table 3.1: Labor Costs

Name	Hourly Rate	Hours	Total	Total x 2.5
Zhihua Gong	180 CNY	128	23040 CNY	57600 CNY
Wenhan Jiang	180 CNY	128	23040 CNY	57600 CNY
Lunan Ke	180 CNY	128	23040 CNY	57600 CNY
Kuangji Chen	180 CNY	128	23040 CNY	57600 CNY
			Total	230400 CNY

3.2 Parts

Table 3.2: Parts

Part	Vendor	Cost/unit (CNY)	Quantity	Total Cost (CNY)
Arduino	Taobao	295 CNY	1	295 CNY
57 stepper motor	Taobao	50 CNY	3	150 CNY
57 stepper motor driver	Taobao	70 CNY	3	210 CNY
Dupont thread	Taobao	7 CNY	2	14 CNY
9V1A power supply	Taobao	9 CNY	1	9 CNY
24V3A power supply	Taobao	25 CNY	2	50 CNY
Power cord	Taobao	3 CNY	1	3 CNY
			Total	731 CNY

3.3 Grand Total

Table 3.3: Grand Total

Name	Cost
Labor	230,400¥
Parts	731¥

Table 3.3 continued from previous page

Name	Cost
-------------	-------------

Total	231,131¥
--------------	-----------------

4 Schedule

Table 4.1: Project Schedule and Task Allocation

Week	Task	Responsibility
03/25/24	Design Document Due	All
	Finalize Design Document	Zhihua
	Purchase Arduino and motor	Kuangji
	Draw CAD and prepare 3D printing	Lunan
	Calculate orbital projection	Wenhan
04/01/24	Teamwork Evaluation I due	All
	PCB design	Zhihua
	Purchase Satellite model and laser adjustment	Kuangji
	Finish 3D printing	Lunan
	Program auduino and connect them to motor	Wenhan
04/08/24	Individual Progress Report Due	All
	Test PCB with satellite movement and laser	Zhihua
	Test Earth rotation and stand structure	Lunan
	Test and Fine-tune motor	Wenhan,Kuangji
04/15/24	Design Document Revision Due	All
	Finalize Design Document Revision	Zhihua
	Assemble the L-shape stand for globe and the platform	Lunan
	Connect and Test the Arduino-motor unit	Wenhan,Kuangji
04/22/24	Assemble the pole for satellite	Lunan
	Connect and Test the Arduino-motor unit	Zhihua,Wenhan,Kuangji
04/29/24	Assemble all components	Lunan
	Do whole-part test of all circuit and elements	Zhihua,Wenhan,Kuangji

Table 4.1 continued from previous page

Week	Task	Responsibility
05/06/24	Mock Demo	All
	Make sure that all parts go well	All
	Prepare for final demo and presentation	All
05/13/24	Final Demo and presentation	All
	Final Individual Design Report Due	All
05/20/24	Final Report Due	All
	Teamwork Evaluation II due	All

5 Ethics and Safety

In the development and implementation of our 3D hardware demonstrator for visualizing satellite-Earth interactions, ethical and safety considerations are paramount. We commit to prioritizing the safety, health, and welfare of the public in our project activities. Specifically, we will ensure that our demonstrator does not pose physical risks to users, such as electrical hazards or moving parts that could cause injury. To prevent accidental or intentional misuse, we will implement safety features like enclosed moving parts and secure electrical connections and provide comprehensive user guidelines.

5.1 Safety

Regarding safety and regulatory standards, our project will comply with relevant state and federal regulations, industry standards, and campus policies. This includes adhering to electrical safety standards (e.g., UL standards), mechanical safety standards (e.g., ANSI standards), and any specific regulations regarding educational tools and devices. We will review and follow the guidelines set by the Consumer Product Safety Commission (CPSC) and the Occupational Safety and Health Administration (OSHA) to ensure our project meets all required safety criteria.

Potential safety concerns include electrical safety (risk of shock or fire), mechanical safety (risk of pinching or other injuries from moving parts), and laser safety (if applicable, ensuring the laser used for satellite positioning does not pose a risk to eyesight). To mitigate these risks, our design will include protective casings for electrical components, safety guards around moving parts, and the use of low-power, eye-safe lasers, compliant with the International Electrotechnical Commission (IEC) standards for laser safety.

5.2 Ethics

Ethically, we recognize the importance of presenting accurate and unbiased educational content, thereby upholding the integrity and respect for intellectual property stipulated in the IEEE Code of Ethics. Our project will incorporate measures to ensure the educational materials and software used are freely and ethically sourced or developed in-house, with proper attribution and licensing where applicable.

To be more precise, we will follow the codes listed below:

- 1. to hold paramount the safety, health, and welfare of the public, to strive to comply with ethical design and sustainable development practices, to protect the privacy of others, and to disclose promptly factors that might endanger the public or the environment;

- 2. to improve the understanding by individuals and society of the capabilities and societal implications of conventional and emerging technologies, including intelligent systems;
- 3. to avoid real or perceived conflicts of interest whenever possible, and to disclose them to affected parties when they do exist;
- 4. to avoid unlawful conduct in professional activities, and to reject bribery in all its forms;
- 5. to seek, accept, and offer honest criticism of technical work, to acknowledge and correct errors, to be honest and realistic in stating claims or estimates based on available data, and to credit properly the contributions of others;
- 6. to maintain and improve our technical competence and to undertake technological tasks for others only if qualified by training or experience, or after full disclosure of pertinent limitations;
- 7. to treat all persons fairly and with respect, and to not engage in discrimination based on characteristics such as race, religion, gender, disability, age, national origin, sexual orientation, gender identity, or gender expression;
- 8. to not engage in harassment of any kind, including sexual harassment or bullying behavior;
- 9. to avoid injuring others, their property, reputation, or employment by false or malicious actions, rumors or any other verbal or physical abuses;
- 10. to support colleagues and co-workers in following this code of ethics, to strive to ensure the code is upheld, and to not retaliate against individuals reporting a violation.

By consciously integrating these ethical and safety considerations into our project design and execution, we aim to provide an educational tool that is not only innovative and engaging but also safe and respectful of ethical standards.

References

1. The block diagrams in this document were created using **boardmix** online platform. Available: <https://boardmix.cn/app/editor>.
2. *IEEE Code of Ethics*. Retrieved March, 2024. Available: <https://www.ieee.org/about/corporate/governance/p7-8.html>
3. *Stepper Motor guide* [Online] <https://blog.csdn.net/zhangdatou666/article/details/132644047?spm=1001.2014.3001.5501>