

ECE 445 Design Document

SnapLog Camera

Tianshu Wei
Xiaofei He
Shuai Huang

Introduction

Problem

Journaling can be repetitive and stressful for children who are asked to record their daily activities for schoolwork, as well as adults who may follow their habits for personal or professional reasons. Not only does it take time, but it also requires mental work to recall, note down, and often describe the events of the day coherently. This approach might be especially tedious when considering the possibility of spending that time on more fun or productive tasks. There is a need for a more simplified, less intrusive manner to capture these everyday events that does not interfere with the enjoyment of the experiences itself.

Solution

SnapLog's core feature is the ability to generate a timelapse—a series of images shot at regular intervals that, when combined, provide a dynamic overview of your day. The camera is set to take an image every few minutes, and each one is quickly and securely delivered to your smartphone. Using a dedicated operation, these photographs are creatively stitched together to produce a cohesive video story, capturing the spirit of your day in an interesting and instructive style. As the day comes to an end, the app finalizes the timelapse, encoding it into a film that can be reviewed or shared, providing a unique way to contemplate and archive your daily journey.

Visual Aid:

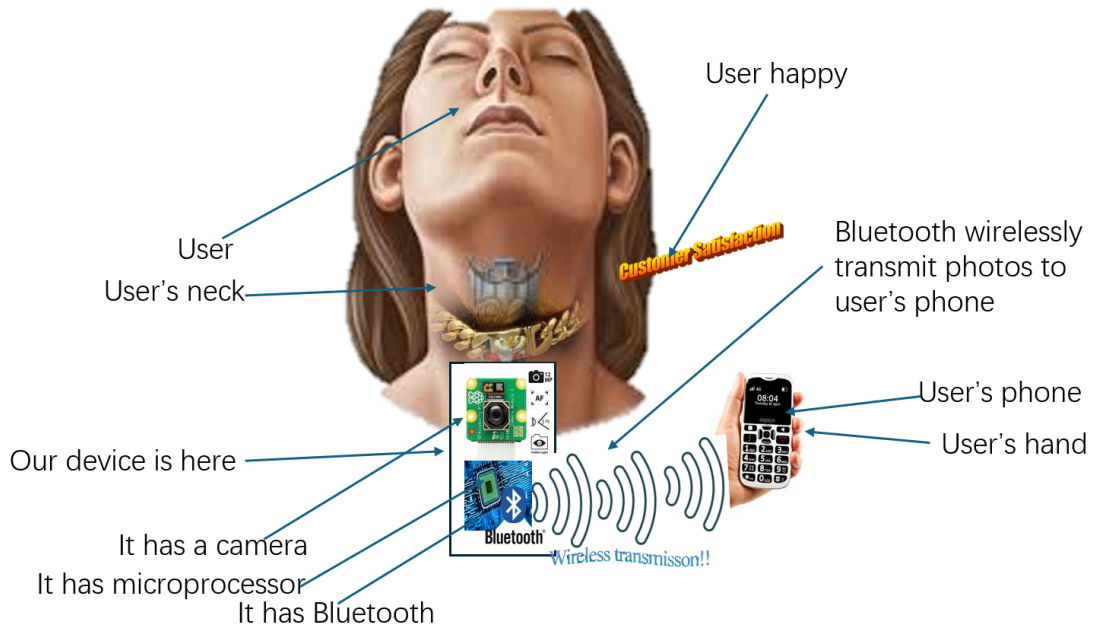

High-level requirements list:

1. The camera is able to take pictures and send them to the host device. The camera will take a photo and transmit it wirelessly, and automatically, to another device. The delay should be within 5 minutes.
2. The camera should be able to take pictures automatically within a certain configurable interval, maximum 5 minutes.
3. Finally, the software on our host device should be able to convert pictures taken in the last 24 hours into video that could be viewed on the device.

Design

Block Diagram:

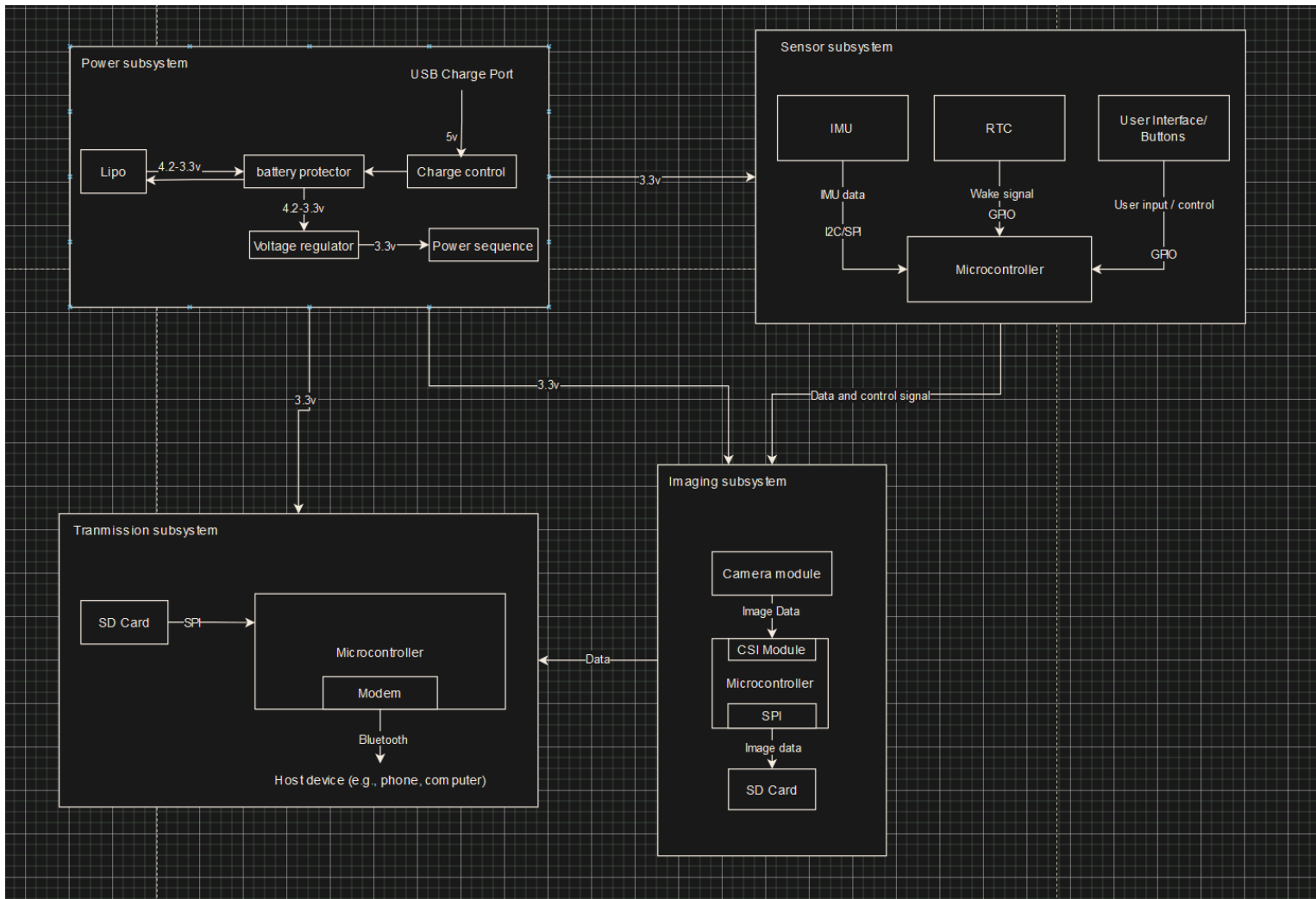

Subsystem Overview:

Our design consists of a few subsystems and each of them perform their own functionalities in order to work together and accomplish the goal of imaging and wirelessly communicating.

Power subsystem: This subsystem controls power to the other subsystems. As the prototype we are developing is aimed to be carried around, it will be powered by a lithium polymer battery. Due to the fact that lithium polymer batteries can be harmed in conditions of overcharging and undercharging, we will design a subsystem to combat this issue. The protection module in our power management module is designed for this task. Another issue of using a battery as a power source is that the voltage will fluctuate. In particular, a lithium battery will have its voltage fluctuate between 3.3v to 4.2v based on its charge level. As a result, we will also incorporate a voltage regulator in our power management submodule to address this issue.

Imaging subsystem: This subsystem capture photo and send the data of it to transmission subsystem. This subsystem handles the task of creating the image. It consists of a camera module, the microcontroller, and a SD card for caching data. The camera module will be controlled from the microcontroller and will communicate with our microprocessor to transfer the data it captured to store it.

Sensor subsystem: This subsystem help the imaging subsystem to enhance the photo quality. This subsystem helps our prototype to sense the world. It consists of the IMU, RTC, and the microcontroller. It helps us to stabilize and enhance the image. It also helps us to set up a proper wake alarm for the microprocessor for it to enter sleep mode to conserve battery life.

Transmission subsystem: This subsystem transmits photo data to the user's phone. The transmission subsystem will finally take the captured image from cache and wirelessly transfer it to the host machine. The data will be sent over bluetooth protocol stack as it is one of the most widespread protocols enabled by consumer electronic devices.

Subsystem Requirements:

Power subsystem: This subsystem should be able to supply other subsystems with at least 3.3v 200mA. This will be tested by using an appropriate resistor and multimeter measuring voltage and current over the resistor that is connected to the output.

Imaging subsystem: This subsystem should be able to generate raw imaging data that is able to be read by the microcontroller. This will be tested using in-program debug functionalities such as serial output or JTAG of the microcontroller.

Sensor subsystem: This subsystem should be able to generate raw sensor data and wake signals that are able to be read by the microcontroller. This will be tested using in-program debug functionalities such as serial output or JTAG of the microcontroller.

Transmission subsystem: The transmission subsystem should be able to wirelessly transmit images to other devices using bluetooth. This will be tested by visually examining the output of the receiving program to see if it is correct.

Tolerance Analysis:

As modern components are designed with power fluctuations in mind, the minimum power supply voltage before brown-out will typically be 3.0V, and highest possible intake voltage will typically be 3.6V. So the voltage tolerance will be $\pm 0.3V$.

Since in this project we are using lithium battery as a power source, the voltage it is capable of supplying is $V_{batt} = 3.7V \pm 0.5V$, and some of its range is well beyond acceptable voltage for our microprocessors, our power module have to be able to step down this voltage to an acceptable range. In this project, we are using regulator to achieve this goal, and the voltage shared by the regulator will be:

$$V_{regulator} = V_{batt} - V_{microcontroller} = 3.7V - 3.0V = 0.7V \geq 0.7V$$

This suggests that a silicon semiconductor should suffice this goal of ours.

Hardware design:

Power:

We are planning to use a Texas Instrument Power Management Integrated Chip to achieve our requirement for this subsystem, specifically TPS65014. Attached is a block diagram of the integrated chip:

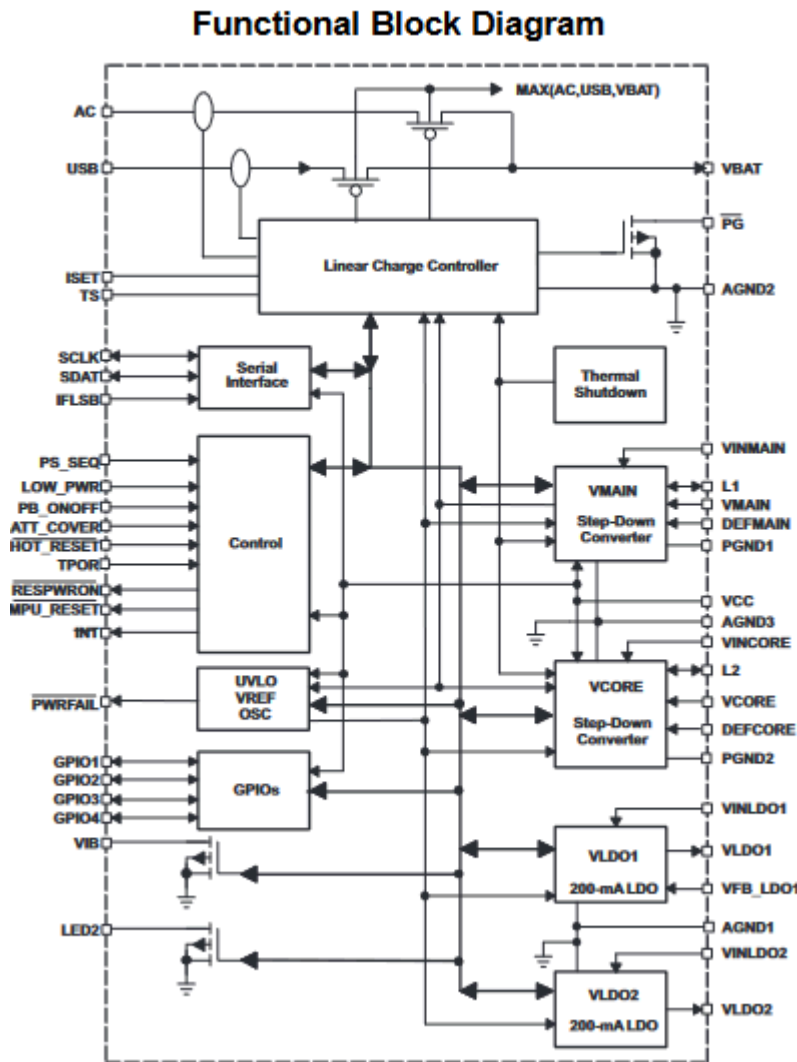

This chip has an integrated linear lithium battery charge controller, 2 linear regulators, and 2 buck converters that are capable of outputting 200mA each and individually adjustable in the range of 0-3.3v and switchable. The chip also offers functions such as power saving mode, external power buttons, and other features such as over-voltage or over-current protection and thermal controls. It satisfies all requirements of our design. The chip has a package of VQFN which helps us to control the cost down.

Pin Configuration and Functions

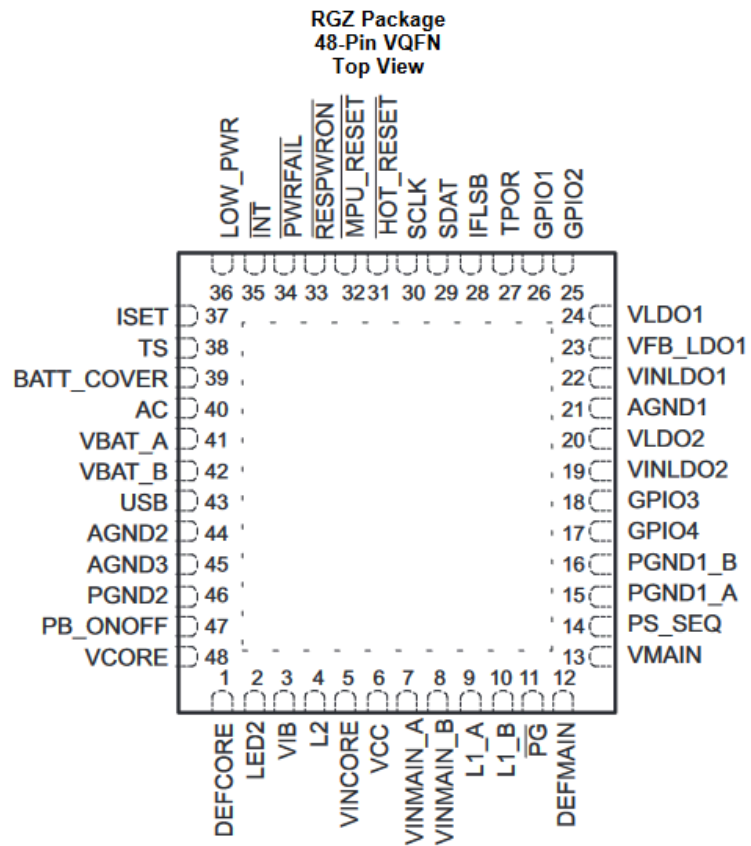

NC – No internal connection

Microcontroller subsystem:

The selected microcontroller is the ESP32-S3 FN8, a low-power MCU-based system-on-chip (SoC) known for its Bluetooth Low Energy (BLE) support. This choice facilitates the SnapLog camera in wirelessly transmitting pictures to user devices, reducing the frequency of battery recharges. Below is the symbol and the pinout of the chip.

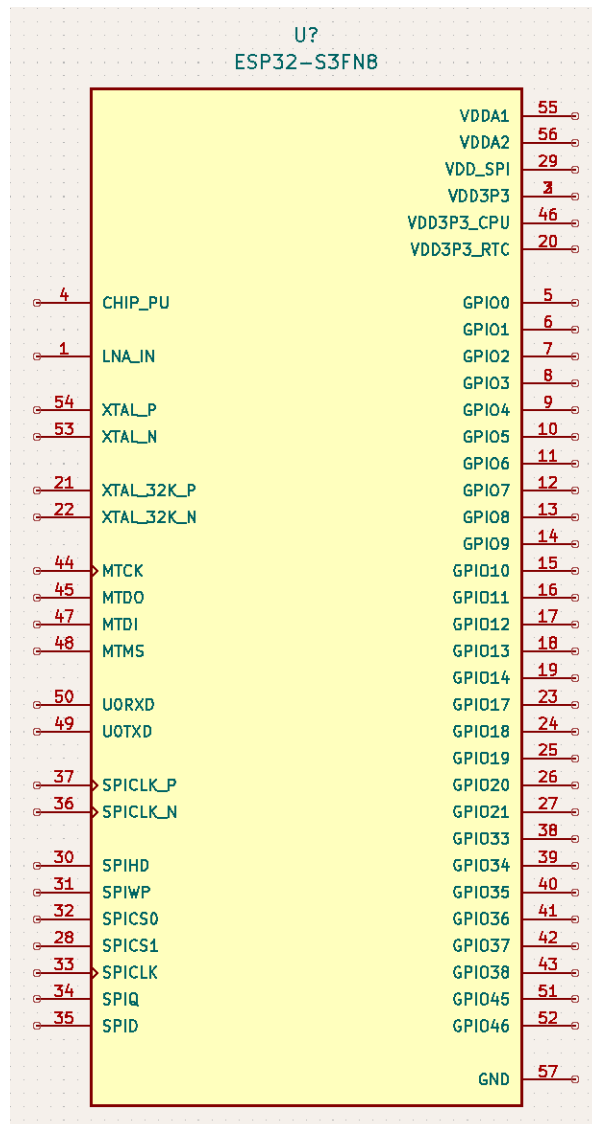

Camera and Sensor:

The module is powered through distinct power domains - analog (AVDD), digital core (DVDD), and I/O (DOVDD). The camera is likely to have features like autofocus (controlled by AF-VDD) and may support additional functionalities like strobe flash synchronization, depending on the exact circuit design and software implementation.

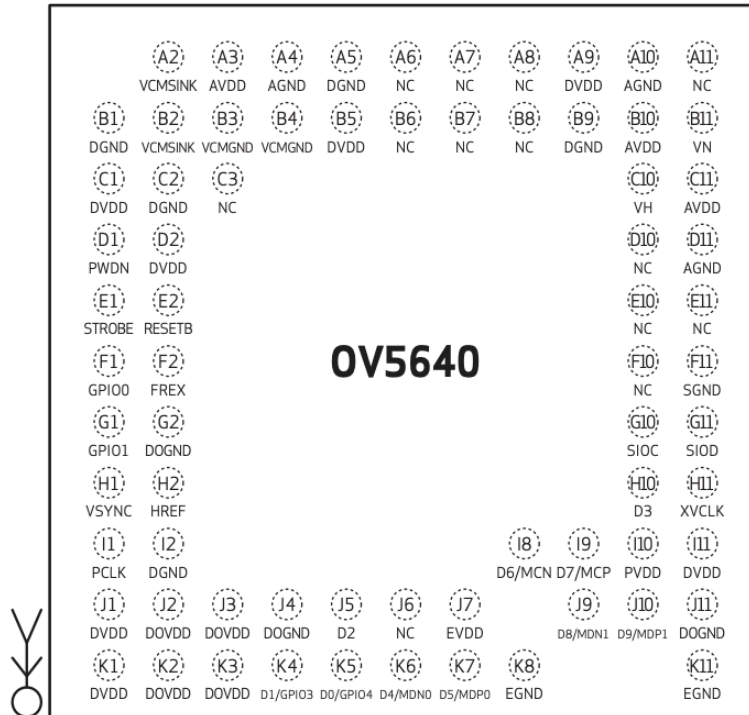

5640 CSP DS 1 1

The microcontroller interfaces with the camera using Serial Camera Control Bus (SCCB) for configuration and commands, and it receives pixel data through a parallel camera interface.

Project timeline

Date	Task	Person
Feb 12-26	<ul style="list-style-type: none"> - Brainstorm and research parts - Make timeline - Bringup board design - Order PCB 	Everyone
Feb 26- Mar 4	<ul style="list-style-type: none"> - Design review & first round PCB review - Wait for PCB - Solder development PCB - Hardware bringup - Debug and update PCB design for class order - Design document presentation 	Everyone
Mar 4 - Mar 11	- (Official) first round class PCB order	Everyone
Mar 11 - Mar 18	Spring Break	Everyone
Mar 18 - Mar 25	<ul style="list-style-type: none"> - (Official) second round class PCB order - Solder first batch PCB and debug - Prototype firmware and software test 	Everyone
Mar 25 - Apr 1	<ul style="list-style-type: none"> - (Official) third round class PCB order - System integration test 	Everyone
Apr 1 - Apr 8	<ul style="list-style-type: none"> - (Official) fourth round class PCB order - Buffer week for failures and expanding tasks 	Everyone
Apr 8 - Apr 15	<ul style="list-style-type: none"> - (Official) fifth round class PCB order - Product assembly - Final system integration 	Everyone
Apr 15 - Apr 22	<ul style="list-style-type: none"> - Mock demo & team contract fulfillment - Final demo 	Everyone
Apr 22 - Apr 29	- Final presentation & final paper due	Everyone
Apr 29 - May	- Have fun	Everyone

Cost Analysis:**BOM:**

Qty	Value	Part	Cost
Power Subsystem			
3	1u	Capacitor	Free
1	0.1u	Capacitor	Free
1	10u	Capacitor	Free
1	2.2u	Capacitor	Free
1	22u	Capacitor	Free
2	/	LED	Free
1	/	USB_B_Micro	0.85
2	/	Conn_01x02	Free
1	/	Conn_01x04	Free
1	/	Conn_01x06	Free
1	10u	Inductor	Free
1	6.2u	Inductor	Free
1	10k	Resistor	Free
1	100	Resistor	Free
1	10	Resistor	Free
2	10k	Resistor	Free
8	1M	Resistor	Free
2	/	SW_Push	Free
1	/	SW_DIP_x01	Free
1	TPS65014	TPS65014	8.83
1	/	OV5640-FPC	6.41
1	/	LP5951MG-2.8	0.48
1	/	LP5951MG-1.5	0.48
Microcontroller & RF Subsystem			

1	/	ESP32-S3FN8	2.28 mouser link
---	---	-------------	----------------------------------

Labors:

Beside material, our main cost for this project will be on labor cost. With the involvement of three brilliant masterminds, the cost of labor is extremely high. Using survey-reflected requirement for labor cost which ended up being \$200/hr, our labor involved being 40hrs/week, and project spanning of 12 weeks with 2 weeks of paid-time-off, this comes to a total cost of $40 * \$200 * 12 * 3 = \96000 pre-tax, rounding to \$100,000 for this project.

Risk Analysis

In our product, the lithium battery could be hazardous if handled improperly. Conditions such as over-voltaging/over-charging(>4.4V), under-voltaging (<2.5V), could cause irreversible damage to the lithium battery and pose a risk of battery catching on fire. Luckily, we selected a power management IC that is capable of protecting against all of these risks. The integrated chip will automatically monitor these voltages and temperature of battery to protect against these situations, and minimize the risks.

Ethics and Safety

Assess the ethical and safety issues relevant to your project. Consider both issues arising during the development of your project and those which could arise from the accidental or intentional misuse of your project. Specific ethical issues should be discussed in the context of the IEEE and/or ACM Code of Ethics. Cite, but do not copy the Codes. Explain how you will avoid ethical breaches. Cite and discuss relevant safety and regulatory standards as they apply to your project. Review state and federal regulations, industry standards, and campus policy. Identify potential safety concerns in your project.

1. Data Security:

The ACM Code of Ethics emphasizes the importance of system designers and developers being vigilant about data privacy and security. Principle 1.6 - "Respect Privacy" obliges computing professionals to preserve the integrity and security of personal data; this principle will guide us in implementing end-to-end encryption for data transfer from the SnapLog camera to the phone application. Moreover, Principle 1.7 - "Honor confidentiality" reinforces our commitment to ensuring that personal data is accessible only to authorized individuals.

2. Accuracy and Reliability:

Principle 2.5 - "Give comprehensive and thorough evaluations of computer systems and their impacts, including analysis of possible risks" will be the cornerstone for developing SnapLog's imaging and timelapse algorithms. This principle underlines the necessity of creating systems that are reliable and that accurately represent the data they process. We will conduct extensive testing to ensure that the representation

of time and events in the timelapses is a true reflection of reality, without any distortion.

3. Hardware Safety:

In accordance with Principle 1.2 - "Avoid harm to others," the physical design of SnapLog will be user-friendly and free of potential hazards, such as sharp edges. We will adhere to industry safety standards to ensure that the device is safe to wear and use. Additionally, Principle 3.1 - "Ensure that the public good is the central concern during all professional computing work" will inform our approach to designing a device that is not only safe for the user but also considers the well-being of those indirectly affected by its use.

4. Wireless Communication:

The Federal Communications Commission (FCC) regulates interstate and international communications by radio, television, wire, satellite, and cable. Devices that utilize Bluetooth technology must adhere to FCC rules to ensure they do not cause harmful interference with other wireless services.

Reference:

Association for Computing Machinery (ACM). (2018). ACM Code of Ethics and Professional Conduct. <https://www.acm.org/code-of-ethics>

Federal Communications Commission. (2021). FCC Regulations.

<https://www.fcc.gov/wireless/bureau-divisions/broadband-division/bluetooth-technology>