

Ready-to-Serve Trash Bin Design Document

Team #19

Dongming Liu
Josh Litao
Owen Xu

TA: Jason Zhang
February 22, 2024
ECE 445

Table of Contents

- 1 Introduction.....3**
 - 1.1 Problem..... 3
 - 1.2 Solution..... 3
 - 1.3 Visual Aid..... 4
 - 1.4 High-Level Requirements..... 4
- 2 Design..... 5**
 - 2.1 Block Diagram..... 5
 - 2.2 Physical Design..... 5
 - 2.3 Motion and Object Detection System Overview and Requirements..... 6
 - 2.3.1 Control System..... 6
 - 2.3.2 Power System..... 7
 - 2.4 Trash Bin System Overview and Requirements..... 7
 - 2.4.1 Control System..... 7
 - 2.4.2 Power System..... 11
 - 2.4.3 Motor System..... 12
 - 2.5 Tolerance Analysis..... 12
- 3 Cost and Schedule..... 14**
 - 3.1 Cost Analysis..... 14
 - 3.2 Schedule..... 15
- 4 Ethics and Safety..... 17**
- 5 Citations..... 19**

1 Introduction

1.1 Problem

Throwing away trash is a simple task that many people take for granted. However, those with little to no mobility as a result of a disability, hospitalization, natural aging, or other health conditions struggle to carry out this necessary task. According to the CDC, 12.1 percent of U.S. adults have a mobility disability with serious difficulty walking or climbing stairs [1]. As a result, these people either require an assistant to dispose of their trash for them, which may not always be feasible, or they are forced to hold their trash and let it accumulate by their side. Letting trash accumulate is a sanitary concern that could escalate into further problems. A trash bin could be placed next to the person, but this solution has various problems. An open trash bin would allow the odor of the trash to spread throughout the room, and a bin with a lid could pose difficulty for users whose conditions make them unable to open the lid directly with their hands or use their foot to press the pedal.

1.2 Solution

In order to eliminate the problems with existing trash bins for people with limited mobility, we propose a trash bin that would be ready to take a user's trash once they perform a particular hand gesture to call it. A camera will be part of the motion and object detection system. This system to detect the hand gesture would be placed somewhere in the room where it would be able to monitor whether the user needs the trash bin to pick up their trash. The trash bin would be attached to a set of wheels to allow it to move. The lid of the bin would also be controlled to open and close. Once the camera detects that the user wishes to dispose of trash, the camera system would wirelessly communicate with the bin to prompt the bin to move toward the user. Upon arriving at the user, the lid would open, ready to collect the user's trash. Once the user has disposed of trash into the bin, the lid would close, and the bin would return to its resting position. This solution simplifies the process of throwing trash by only requiring the users to call it and drop their trash into the bin.

1.3 Visual Aid

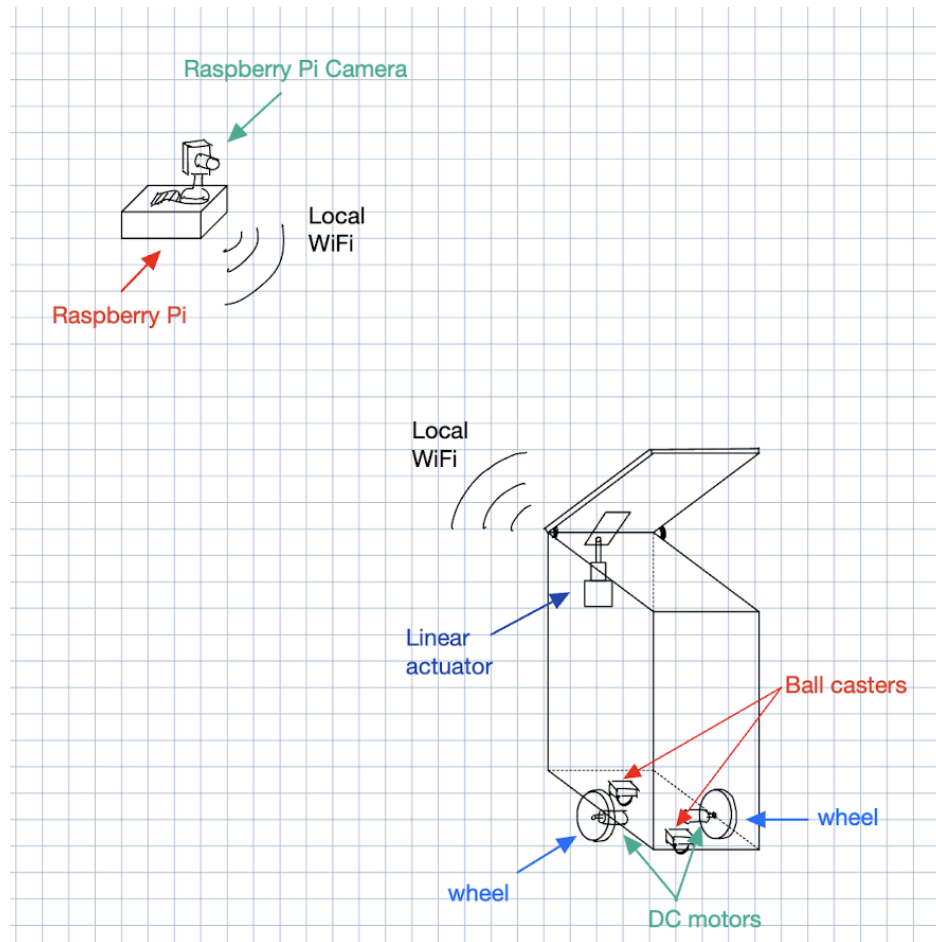

Figure 1: High Level Overview of the Ready-to-Serve Trash Bin

1.4 High-Level Requirements

- The camera system must be able to recognize a person's gesture for calling the trash bin. The camera will only recognize one single gesture, which will be similar to the one when someone is hailing a taxi.
- The trash bin must be able to travel close to the user and return back to its resting position. The distance the bin stops is $25 \text{ cm} \pm 5 \text{ cm}$, a side to side distance.
- The lid of the trash bin must open when collecting trash from the user and remain closed at all other times, including traveling to and from the user. The bin should react in 2 seconds before it begins to travel. And the speed of the bin should be in the range of 1-1.5 m/s. Once the bin reaches the destination, the lid should open in less than 1 second. The lid will remain open for 30 seconds before gradually closing in 1 second and then travel back to the bin station at the same speed as it comes.

2 Design

2.1 Block Diagram

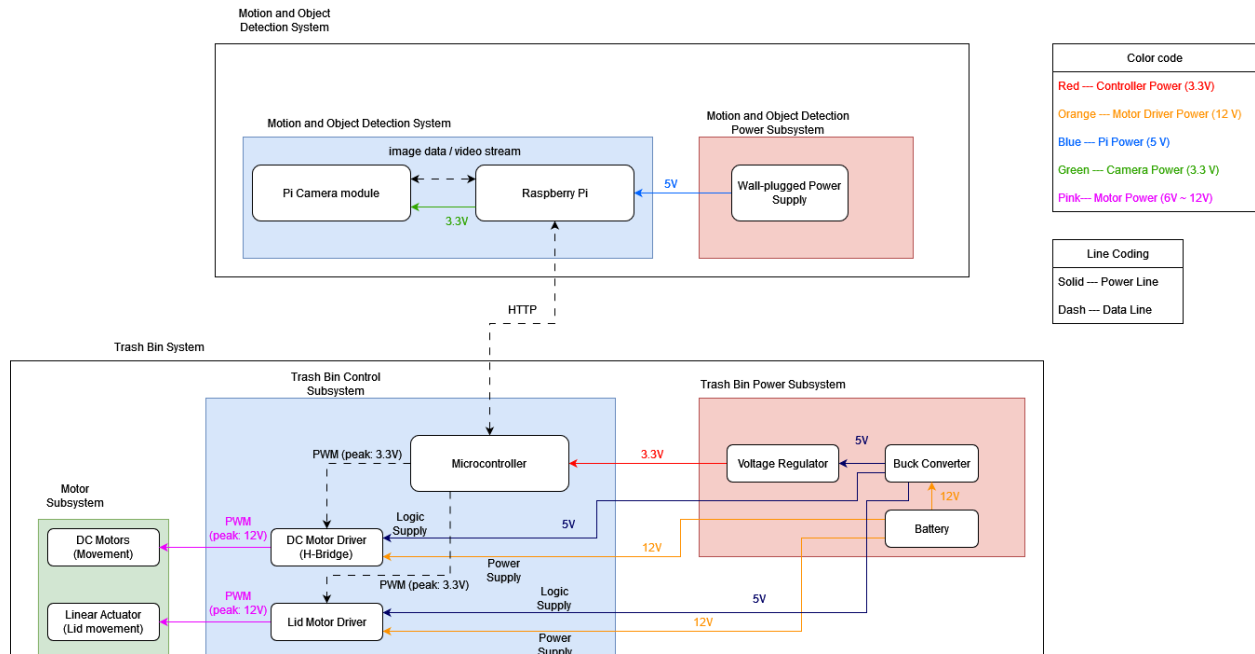

Figure 2: Block Diagram

2.2 Physical Design

The trash bin used in the project has a dimension (L x W x H) of 14.17 x 10.62 x 16.92 Inches (0.3599 x 0.2697 x 0.4298 m). The wheels used in the project have a radius of about 3 inches (0.0762 m). We asked the machine shop to build a chassis for the base (bottom) of the trash bin. The chassis holds a battery holder, PCB with MCU and motor drivers, two DC motors, two metal ball casters, and the trash bin. The DC motors are placed at the centers along the long side (L) of the trash bin. Both metal ball casters are placed in the center of the width (W). Each of the caster is placed on each edge of the long side. The linear actuator is placed vertically near the hinge of the trash lid; it is responsible for opening and closing the lid. The raspberry pi and the connected camera module are placed on the ceiling. It will be positioned to a point where the camera is able to capture the entire moving space.

2.3 Motion and Object Detection System Overview and Requirements

2.3.1 Control System

The Raspberry Pi uses a wall-plug powered camera module (Smraza Raspberry Pi 4 Camera Module) to capture and analyze the environment using computer vision, which will be implemented with YOLOv7. Once the Raspberry Pi recognizes the specific hand gesture, it sends commands with HTTP requests to the trash bin control system via WiFi. It sends the path to the trash bin to the destination. A pre-implemented graph of the room will be imported into the Raspberry Pi unit. Once the camera detects someone is calling the bin, it will use a simple BFS algorithm to find the path leading the bin to that person. The bins, after reaching the destination will report to Raspberry Pi, which will then send the command of opening the lid. After 30 seconds, Raspberry Pi will send another command to close the lid. Then, depending on whether the bin has a new destination to travel to, Raspberry Pi will either send the bin to the new location or back to resting points. For each command Raspberry Pi sends to the bin, the Raspberry Pi unit waits until the trash bin responds (an HTTP response).

Requirement	Verification
<p>The Raspberry Pi needs to continuously power the Raspberry Pi camera module with a voltage of $3.3V \pm 0.2V$</p>	<p>Power on the Raspberry Pi. Look for the Pi camera connector (a rectangular 15-pin connector near the 3.5mm audio jack with the label “camera”)</p> <p>Turn on a multimeter. Put the negative probe on PIN 1 of the connector and the positive probe on PIN 15. Then, check the voltage readings from the multimeter and see whether it is within the range of $3.3V \pm 0.2V$.</p> <p>Note: PIN 1 is the left furthest pin from the label “camera” and PIN 15 is the right furthest pin from the label “camera”.</p>
<p>The RTT (Round Trip Time) of the communication should be no more than 700ms.</p>	<p>Power on the MCU and flash the code to the MCU. The code will output the IP address of the MCU on the serial monitor on the Arduino IDE.</p> <p>Power on the Raspberry Pi and open the terminal on Pi. Type ping ip_address_of_mcu -c <n> in the terminal, where n is specified as the number of packets. By default, n = 20. The time section of the ping output is the RTT of the communication between Pi and MCU. Compare the output and see whether it is within the limitation.</p>

2.3.2 Power System

A power adapter (iRasptek Raspberry Pi 4 Power Adapter) will power the Raspberry Pi 4B and the Raspberry Pi camera module. The Raspberry Pi 4B will receive power from its USB-C port and supply power to the camera module through its onboard camera module port.

Requirement	Verification
The power adapter should continuously provide at least 5V	Connect the USB-C output to a USB-C power tester and connect the USB-C tester to the Raspberry Pi. Then, verify the voltage reading and power reading.
The power adapter should continuously supply at least 15 W	Connect the USB-C output to a USB-C power tester and connect the USB-C tester to the Raspberry Pi. Then, verify the voltage reading and power reading.

2.4 Trash Bin System Overview and Requirements

2.4.1 Control System

The control system of the trash bin system is responsible for receiving commands from the motion and object detection system and sending control signals to the motors. It also collects the feedback from the motors to better adjust the control. It is powered by the power system of the trash bin system. The MCU maintains feedback recollections and control calculation at a rate of 100 ± 10 Hz. The MCU distinguishes different commands and adjusts the speed, by controlling the duty cycle of the PWM signals to the motor drivers. The motor drivers amplify the incoming PWM signals based on their referenced voltages and output to the motors. The MCU we planned to use is ESP32-S3-WROOM-1-N16R8. This model has 16 MB on-chip flash and 8 MB PSRAM, and it helps provide more space for storing our program. ESP32-S3 has a built-in WiFi and Bluetooth module, introducing remote control and wireless communication [2]. The motor drivers controller we use is L298N. The L298N chip supports a large range of voltage source and current [3]. It is also easy to use. The schematic in Figure 5 is based on the module schematic from [4].

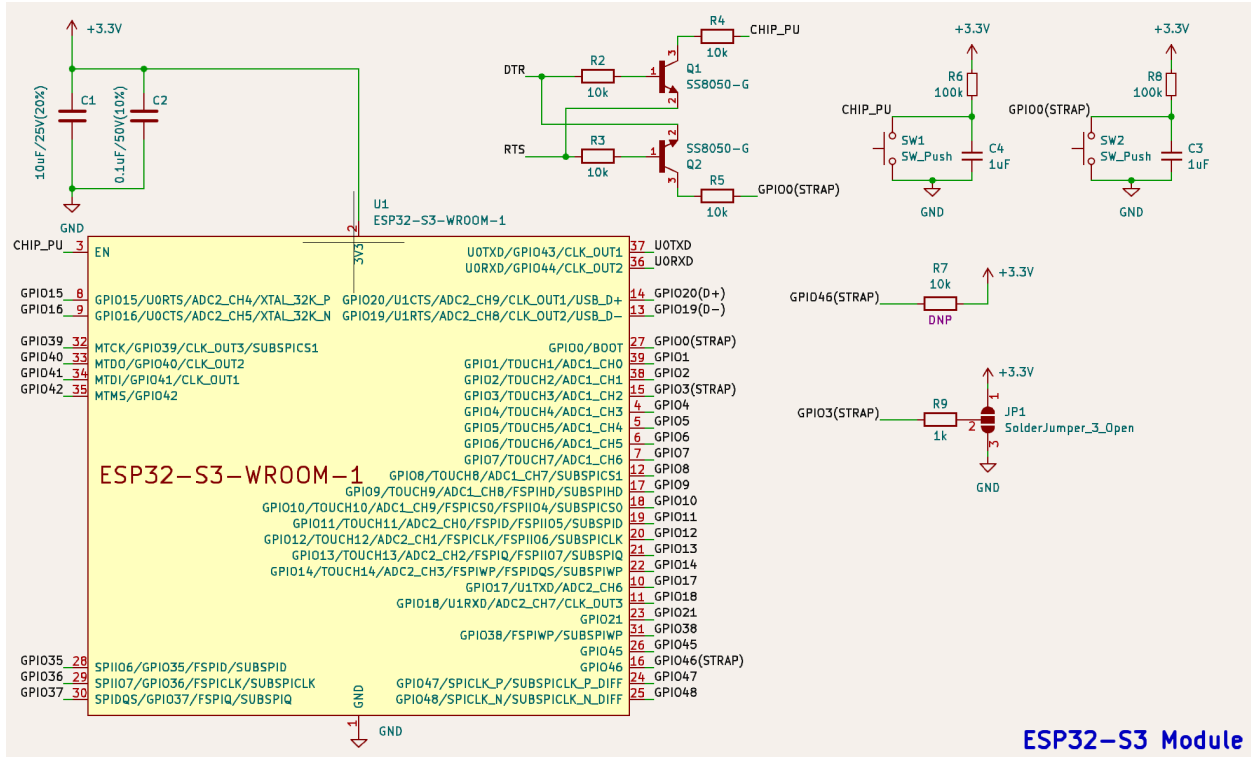

Figure 3: Microcontroller Schematic

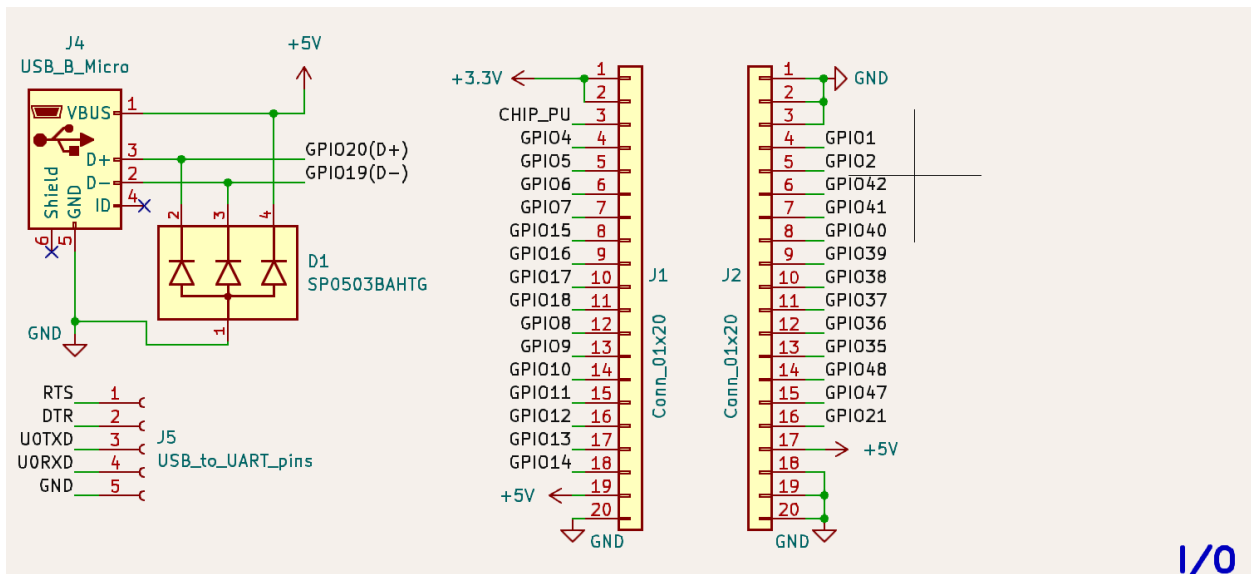

Figure 4: I/O Schematic

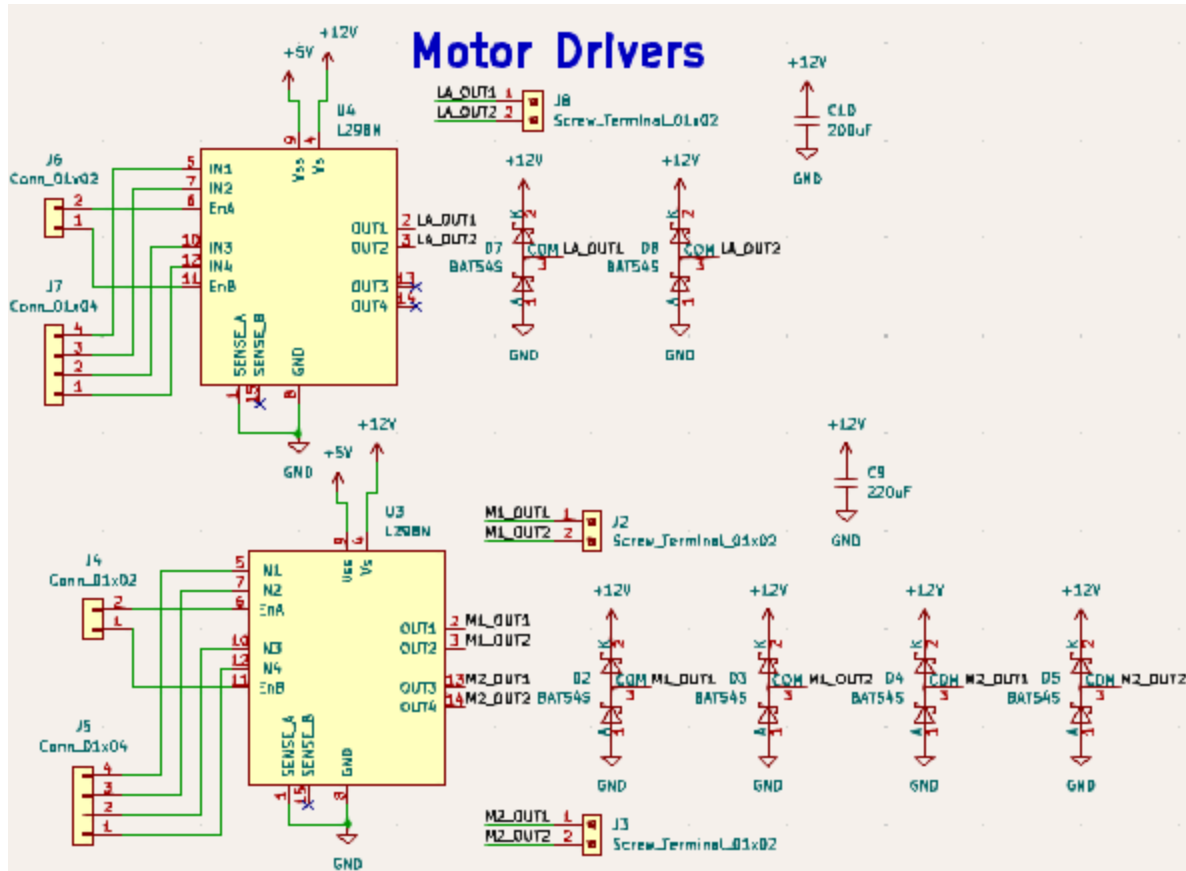

Figure 5: Motor Drivers Schematic

Requirement	Verification
The MCU needs to ensure a persistent WiFi connection	<p>Connect the USB of the MCU board to a laptop.</p> <p>Write and upload a program that continuously verifies the WiFi connection every 1 to 2 seconds using Arduino IDE. The program writes messages of successful connection and connection failure to the Arduino serial monitor.</p> <p>Write a Python script that records the output of the serial port that connects to the MCU and outputs a log file once execution finishes.</p> <p>Run the MCU program and the Python script simultaneously for at least 30 minutes. Once the Python script finishes running, check the</p>

	<p>log and see if the log contains any message regarding connection failure.</p> <p>To test the stationary and moving condition, we will verify to see if the connection is stable under the following scenarios:</p> <ul style="list-style-type: none"> - The bin is behind the wall and/or in the other room next to the router position.(stationary) - Some obstacles or people are around the bin.(stationary) - The bin is moving towards or away from the router. (moving)
<p>The MCU needs to receive at least 90% of the requests (commands) coming from the Motion and Object Detection System.</p>	<p>Connect the USB of the MCU board to a laptop.</p> <p>Write a Python script that periodically sends different requests (commands) to the MCU. By default the testing period would be every 2 ± seconds. Put a serial print statement in the command handler code, and upload the code to the MCU</p> <p>Reuse script for recording the Arduino serial monitor and outputting a log.</p> <p>Let the MCU and Python script run for at least 30 minutes. Once the Python script finishes running, check the log and see if total commands received is at least 90% of total commands sent.</p>
<p>The MCU needs to distinguish different commands, set the correct duty cycles of the PWM signals, and output the PWM signals to the motor drivers.</p>	<p>Connect the PWM output pins of the MCU to an oscilloscope and the USB port of the MCU to the laptop.</p> <p>Writing a testing function in Arduino IDE. The function takes in inputs from the serial port and change commands (to simplified the testing, each command has an integer ID)</p> <p>Check the waveform on the oscilloscope and see if the PWM cycle is adjust accordingly</p>

2.4.2 Power System

The power system of the trash bin system needs to provide the right voltage levels to the ESP32 microcontroller and the motor drivers. Our motors require 12 V DC. Additionally, the motor driver runs on 5 V logic, whereas the microcontroller runs on 3.3 V logic. As a result, we will have to convert between different voltage levels. We decided that we will power the trash bin with a 12 V battery since we are using 12 V motors. The 12 V battery output would directly connect to the motor drivers to provide power to the motors. Our microcontroller runs on 3.3 V and requires a current input of about 0.5 A [2]. If we perform this voltage conversion through a linear regulator, it would dissipate 4.35 W of power, which would be inefficient and significantly heat up the board. These concerns are discussed more in detail in Section 2.5 Tolerance Analysis. Because of the large voltage drop and the need for an intermediate voltage, we need to use a buck converter to first step down the voltage to 5 V. The TPS562201 buck converter can take in 12 V and output 5 V with a maximum output current of 2 A [5]. This 5 V output then connects to the motor drivers to supply the logic voltage. Finally, we connect the 5 V output from the buck converter to the voltage regulator to output a regulated 3.3 V to the microcontroller. We chose the TLV1117LV as it has a variation that can output 3.3 V at 1 A, which is sufficient for the microcontroller [6].

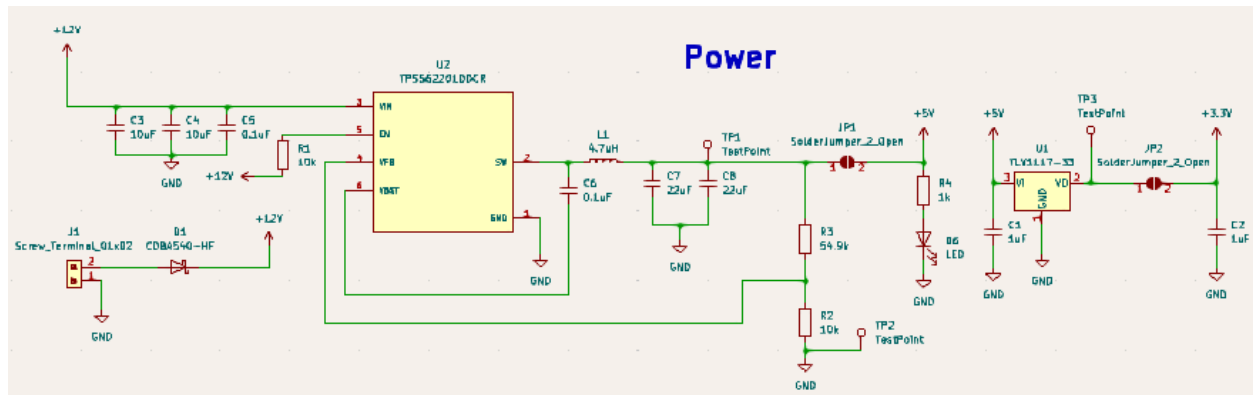

Figure 6: Power Schematic

Requirement	Verification
The power system needs to provide a voltage with a range from 6V to 12V to the DC motor and a voltage with a range from 6V to 12V to the linear actuator.	Using a digital multimeter, measure the output voltage of the battery.
The buck converter of the power subsystem should supply a voltage of 5 V \pm 0.5 V.	Using a digital multimeter, measure the output voltage of the converter.

The voltage regulators of the power subsystem should supply a voltage of $3.3V \pm 0.2V$ and a current of $550\text{ mA} \pm 0.50\text{ mA}$ to the MCU.	Using a digital multimeter, measure the output voltage of the LDO. Using a digital multimeter, measure the output current of the LDO.
--	--

2.4.3 Motor System

The motor system controls the movement of the trash bin. It is powered by the power subsystem and controlled by the control subsystem. The two DC-g geared motors help the trash bin move around in the space (forward, backward, left turn, right turn). The linear actuator controls the opening and closing motion of the trash bin lid.

Requirement	Verification
The DC motor can work in the range of 6V and 12 V	<p>Connect the positive and the negative ends of the motor to the voltage source and multimeter.</p> <p>Set the voltage source to 6V, check the output from the multimeter, and see if the motor is turning</p> <p>Repeat this process for 7 to 12V voltage source</p>
The linear motor can work in the range of 6V to 12 V	<p>Connect the positive and the negative ends of the motor to the voltage source and multimeter.</p> <p>Set the voltage source to 6V, check the output from the multimeter, and see if the motor is turning</p> <p>Repeat this process for 7 to 12V voltage source</p>

2.5 Tolerance Analysis

The diameter (d) of the wheel is about 6 inches (0.1524 m). When the motor is not loaded, the RPM of the motor is at least 150.

$$C = \pi d = 0.1524 * \pi = 0.47878\text{ m}$$

$$\text{Speed per second} = \text{RPM} * C = 150 * 0.47878 / 60 = 1.19634\text{ m/s}$$

With no load, the speed of the DC motor is 1.19634 m/s. It is close to the lower end of the average walking speed.

Torque and force analysis for the DC gear motors of overall design:

- τ_w = the torque of motor (Nm)
- R_w = the wheel radius (m)
- μ_w = static friction coefficient of the wheels against the floor
- μ_c = static friction coefficient of the metal caster against the floor
- m_T = total mass (kg)
- F_N = normal force (N)
- F_g = weight/gravitational force (N)
- F_{wf} = static friction of the wheel (N)
- F_{cf} = static friction of the metal caster (N)
- g = gravitational acceleration constant (m/s²)

Two DC gear motors are at the same position, and they exert the same amount of torque. We can derive the following formula based the Newton's Second Law of rotational motion:

$$2\tau_w = F_{wf} * R_w \quad (1)$$

In rolling without slipping, the static friction of the wheels cannot exceed the static friction of the total mass. The static friction of the total mass is the normal force times the friction coefficients. Given that we have two different types of wheels (one is metal, and the other is plastic).

Assuming the internal friction and friction from the bearing are negligible, we have:

$$F_{wf} \leq F_N * (\mu_w + \mu_c) \quad (2)$$

Based on Newton's Second Law, $F_g = m_T * g$. Given that the entire trash bin is not accelerating up and down, $F_g = F_N$.

So the static friction of the total mass can be computed with the following formula:

$$m_T * g * (\mu_w + \mu_c) \quad (3)$$

Putting this into the inequality equation (2)

$$\frac{2\tau_w}{R_w} \leq m_T * g * (\mu_w + \mu_c) \quad (4)$$

Rearranging (4), we can determine the required torque of the DC gear motors based on our target mass

$$\frac{2\tau_w}{R_w * g * (\mu_w + \mu_c)} \leq m_T \quad (5)$$

The wheels have a radius of 3 inches (0.762m). The wheels and metal caster have a friction coefficient of approximately 0.5 when rolling on the hospital flooring. We estimate that the summing mass of our finished product and its load is about 5 to 6 lbs (2.3 kg to 2.8 kg). With this information, in theory, we need both motors to provide a torque of at least 0.373 Nm.

Since we are using a voltage regulator to step down the battery voltage to a fixed voltage for the microcontroller, we have to verify that we will not draw too much power and risk overheating the component. The microcontroller needs about 0.5 A of current delivered from its power source, and it takes in a voltage of 3.3 V. Our battery voltage is 12 V to meet the needs of the motors. From these requirements, we can calculate the power that the regulator would have to dissipate:

$$P_D = i_{out}(v_{in} - v_{out}) \quad (6)$$

Using (6) with the parameters the regulator would have, we find that it would consume 4.35 W of power, which is a large amount for a small component. Knowing how much power the regulator would dissipate, we calculate the junction temperature to see how it would compare to the maximum junction temperature on the datasheet. For this analysis, we use [7] as a representative for typical voltage regulators we would consider.

$$T_j = P_D \Theta_{ja} + T_a \quad (7)$$

The junction-to-ambient thermal resistance is about 100 °C/W. We use an ambient temperature of 38°C, which could happen if the circuit heats up. Therefore, the junction temperature, according to (7), will be 473°C, which is higher than the maximum temperature of the linear regulator. Therefore, we would need a buck converter to step down the voltage before applying it to the voltage regulator.

3 Cost and Schedule

3.1 Cost Analysis

Description	Manufacture	Part Number	Quantity	Cost
Raspberry Pi Model 4B	Raspberry Pi	SC0193	1	\$61.79
Raspberry Pi Camera	Smraza	SM39	1	\$16.99
Raspberry Pi 4 Power Adapter	iRasptek	MKE-0513500H	1	\$9.99
ESP32-S3-WROOM-1-N16R8	Espressif Systems	ESP32-S3-WROOM-1-N16R8	1	\$3.90
Trash Bin	Mainstays	MS202376BLK	1	\$10.62

Motor Driver Chip	STMicroelectronics	L298N	2	\$11.20
3.3-V LDO Regulator	Texas Instruments	TLV1117LV	1	\$0.35
2-A Synchronous Buck Converter	Texas Instruments	TPS562201	1	\$0.44
4.7 μ H Fixed Inductor	Vishay Dale	IHLP2525CZER4R7M01	1	\$1.15
12 V DC Motor	Weiheng Transmission Technology	JGB37-520	2	\$5.75
12 V Linear Actuator	Rtisgunpro	MN	1	\$19.99
Metal Ball Caster	DFRobot	FIT0007	2	\$2.50
Push button	KMR231NG ULC LFS	C&K	2	\$0.55
TVS DIODE	SP0503BAHTG	Littelfuse Inc.	1	\$0.86
NPN Transistor	SS8050-G	Comchip Technology	2	\$0.29
Total				\$166.66

We assume the hourly salary is \$40/hr and expect that we can have a salary of $40\$/hr * 2.5 * 65 hr = \6500 per person. There are three members in the team, so the total cost for labor is $\$6500 * 3 = \19500 . Adding the costs of the parts, the total cost of our project is $\$166.66 + 19500 = \19666.66 .

3.2 Schedule

Week	Task	Person
2/26 - 3/1	Design Review	All
	Design PCB (ESP32S3 schematic)	Dongming
	Design CV system	Owen
	Design PCB (Power system and Motor Drivers)	Josh
3/4 - 3/8	First Round PCBway Order, Teamwork Evaluation I	All
	Writing MCU code (motor controlling)	Dongming
	Design and Train the CV system	Owen
	Finish initial PCB design, Assist with MCU motor code	Josh

3/11 - 3/15	Spring Break	All
3/18 - 3/22	Initial testing	All
	Writing MCU code (motor controlling)	Dongming
	Train and test the CV system	Owen
	Test Hardware, PCB Revisions, Assist with MCU motor code	Josh
3/25 - 3/29	Individual Progress Reports, Second PCBway Order	All
	Writing MCU code (communication) and integrating motor code	Dongming
	Test on camera video streaming and signal input/output, design algorithms of finding the path to distance	Owen
	Finish PCB Revisions, Assist with testing	Josh
4/1 - 4/5	Begin integration and tests	All
	Writing MCU code (communication) and integrating motor code	Dongming
	Test on sending output command	Owen
	Start Board Integration Tests	Josh
4/8 - 4/12	Final Integration Tests, Finalize Assembly	All
	Overall testing for MCU controls and MCU communication	Dongming
	Overall testing	Owen
	Overall testing for hardware	Josh
4/15 - 4/19	Mock Demo, Team Contract Fulfillment, Final Debugging	All
4/22 - 4/26	Final Demo, Mock Presentation	All
4/29 - 5/3	Final Presentation, Final Paper Due, Lab Notebooks Due	All

4 Ethics and Safety

To ensure a successful project, it is important that we follow the IEEE Code of Ethics. Our project has some safety and privacy concerns that we must address as per Section I.1 of the Code [8]. Since our product is targeted towards those with limited mobility, we need to take care that our product accommodates for their safety as well.

The power subsystems for both the Trash Bin System and the Motion and Object Detection Systems have different safety concerns that must be addressed. The trash bin would be powered by batteries, which could overheat, cause a fire, or create a shock. To minimize the chance of batteries overheating, we will ensure that the power needs of our motors, drivers, microcontroller, do not exceed what the batteries can provide. The Raspberry Pi and the camera would be using a plug to receive power from a 120VAC outlet. Since electric shocks will be severe with this voltage, we need to warn the user of the dangers.

When the trash bin is moving, it could potentially collide with people and obstacles. Since the trash bin is only moving at walking speeds, which is about 1 m/s, and the trash bin will not be too heavy, the impact of a collision would be minor. Additionally, people would have ample time to react with the trash bin traveling at a low speed. When planning the path to destination, the bin will prefer to walk along the middle of the corridor, as people with immobility tend to walk against the wall, such path planning can reduce the possibility that the bin collides with them. Another concern related to movement is objects getting caught in the wheels and gear motors, which would damage both the drive system and object caught. While there is not much we can do on our end, we would have to warn the user of moving parts and rely on the user to keep the trash bin's path clear.

Since the product is designed to collect trash, various kinds of solid and liquid materials will enter our product, which could potentially create sparks and other hazards if they come in contact with the electronics. To mitigate this risk, the electronics would be housed underneath the trash bin where they will be separated from the trash inside the bin. During normal operation, the user should not be able to easily access the circuit. And it is the duty of the users to check regularly the situation of the battery to ensure the whole system is in good condition.

Since the lid of the bin is automatically controlled, the lid may jam people's fingers when they are throwing trash. To avoid this issue, we will extend the time of the lid remaining open to cooperate with the fact that people with limited mobility may need more time to finish throwing all their trash. Moreover, the lid will close gradually which will give people enough time to react and reduce the impact if a jam occurs. And in the worst case, since the bin is made with light-weight materials, a jam will not be severe.

A privacy concern must be addressed since we are using a camera in this project. The camera is only used to capture users' hand gestures and will have no local or online storage for these photos, which means all the information the camera has is for one-time use. The camera will not need to capture photos to improve the machine learning output, as the model will be trained with a huge data size which significantly outnumbered the number of pictures the camera captures in daily use, making the new learning progress have little effect. The camera will also not transmit photographic data to other devices. The only data that the camera system sends out is whether a gesture to call the trash can was made.

5 Citations

- [1] “Disability Impacts All of Us.” Centers for Disease Control and Prevention. <https://www.cdc.gov/ncbddd/disabilityandhealth/infographic-disability-impacts-all.html>. (accessed February 6, 2024).
- [2] *2.4 GHz Wi-Fi (802.11 b/g/n) and Bluetooth® 5 (LE) module*, Espressif Systems, 2023, v1.3. [Online]. Available: https://www.espressif.com/sites/default/files/documentation/esp32-s3-wroom-1_wroom-1u_datasheet_en.pdf.
- [3] *Dual full-bridge driver*, STMicroelectronics, 2023, Rev. 5. [Online]. Available: <https://www.st.com/content/ccc/resource/technical/document/datasheet/82/cc/3f/39/0a/29/4d/f0/CD00000240.pdf/files/CD00000240.pdf/jcr:content/translations/en.CD00000240.pdf>.
- [4] *L298N Dual H-Bridge Motor Driver*, Handson Technology. [Online]. Available: <https://www.handsontec.com/dataspecs/module/L298N%20Motor%20Driver.pdf>
- [5] *TPS56220x 4.5-V to 17-V Input, 2-A Synchronous Step-Down Voltage Regulator in 6-Pin SOT-23*, Texas Instruments, 2020, Rev. B. [Online]. Available: <https://www.ti.com/lit/ds/symlink/tps562201.pdf>.
- [6] *TLV1117LV 1-A, Positive Fixed-Voltage, Low-Dropout Regulator*, Texas Instruments, 2023, Rev. C. [Online]. Available: <https://www.ti.com/lit/ds/symlink/tlv1117lv.pdf>
- [7] *Low Dropout Linear Regulator*, Diodes Incorporated, 2022, Rev. 5-2. [Online]. Available: <https://www.diodes.com/assets/Datasheets/AZ1117C.pdf>
- [8] “IEEE Code of Ethics.” IEEE. <https://www.ieee.org/about/corporate/governance/p7-8.html>. (accessed February 7, 2024).