

ECE 445
SENIOR DESIGN LABORATORY
DESIGN DOCUMENT

Automatic Bike Light System

Team #21

NEERAJ KUMAR
(nskumar2@illinois.edu)

JEREMY QUINTEROS
(jeremyq2@illinois.edu)

BRIAN WOLHAUPTER
(brianaw2@illinois.edu)

TA: Zhicong Fan

February 22, 2022

Contents

1	Introduction	1
1.1	Problem and solution overview	1
1.2	Visual aids	1
1.3	High-level requirements list	2
2	Design	3
2.1	Block Diagram	3
2.2	Physical Design	4
2.3	Power System	4
2.4	Sensor System	6
2.4.1	Ambient Light sensor	6
2.4.2	Headlight Detectors	8
2.4.3	Motion Detection Sensor	9
2.4.4	Handlebar Toggle Switches	10
2.5	Lighting System	11
2.5.1	Front Indicator	11
2.5.2	Rear Indicator	11
2.5.3	Front Headlight	12
2.6	Microcontroller	13
2.7	Tolerance Analysis	15
3	Cost and Schedule	15
3.1	Cost Analysis	15
3.1.1	Labor	15
3.1.2	Parts	16
3.2	Schedule	17
4	Discussion of Ethics and Safety	18
4.1	Potential Ethical and Safety Issues	18
	References	19
	Appendix A Expanded views of module housings	20

1 Introduction

1.1 Problem and solution overview

A bicycle light is one of the most effective ways to improve bicyclist safety while riding at night. Unfortunately, it can be difficult to remember to turn a conventional light on until the rider is in motion, at which point the rider has to either blindly reach for the button on the front and rear light, or take their eyes off the road and look for it in the dark, neither of which is safe. Additionally, it is easy to forget to turn the lights back off, especially if the bike is parked in a well lit area. This results in draining the battery faster than necessary.

Our project addresses these issues by using a series of sensors and a microcontroller to activate and deactivate the lights on the bike. When the system is not in motion, it will turn the lights off, preserving battery life, and then turn them back on when the bike is in motion and it is dark enough to warrant turning the lights on. If the cyclist wants to manually turn the system off or turn the headlight on to provide better illumination of the road ahead, a toggle switch on the handlebars allows the rider to do so without having to take their eyes off the road or remove their hands from the handlebars.

1.2 Visual aids

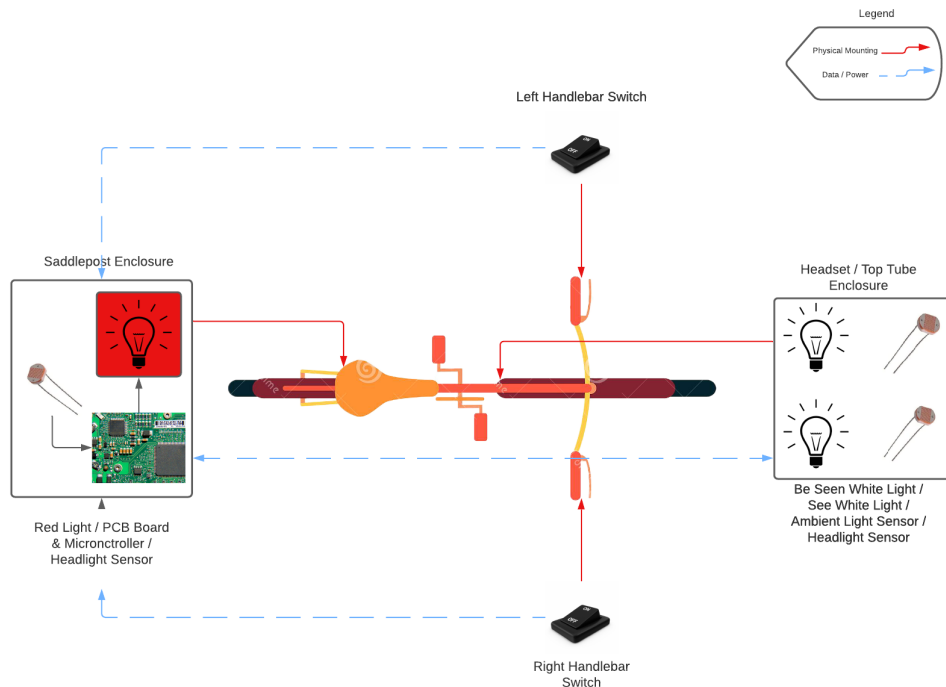

Figure 1: Automatic Bike Light System Visual Aid

1.3 High-level requirements list

To adequately address the problems described above and be considered a success, our project must meet several high level requirements.

- The system must transition from its deep-sleep mode into full operation within 15 seconds of the bicycle being in motion, and transition back to deep-sleep after being stationary for 5 minutes.
- The system must turn on the flashing indicators when the ambient light levels reach that of dusk for more than 10 seconds. The light level at dusk is being defined as 500 lux [1].
- The system should raise the brightness of the indicators in a vehicle is detected within 30 meters.
- The system should activate or deactivate in accordance with the user input from the first handlebar toggle switch. The system should also turn the headlight on or off, depending on the user input from the second handlebar switch.

2 Design

2.1 Block Diagram

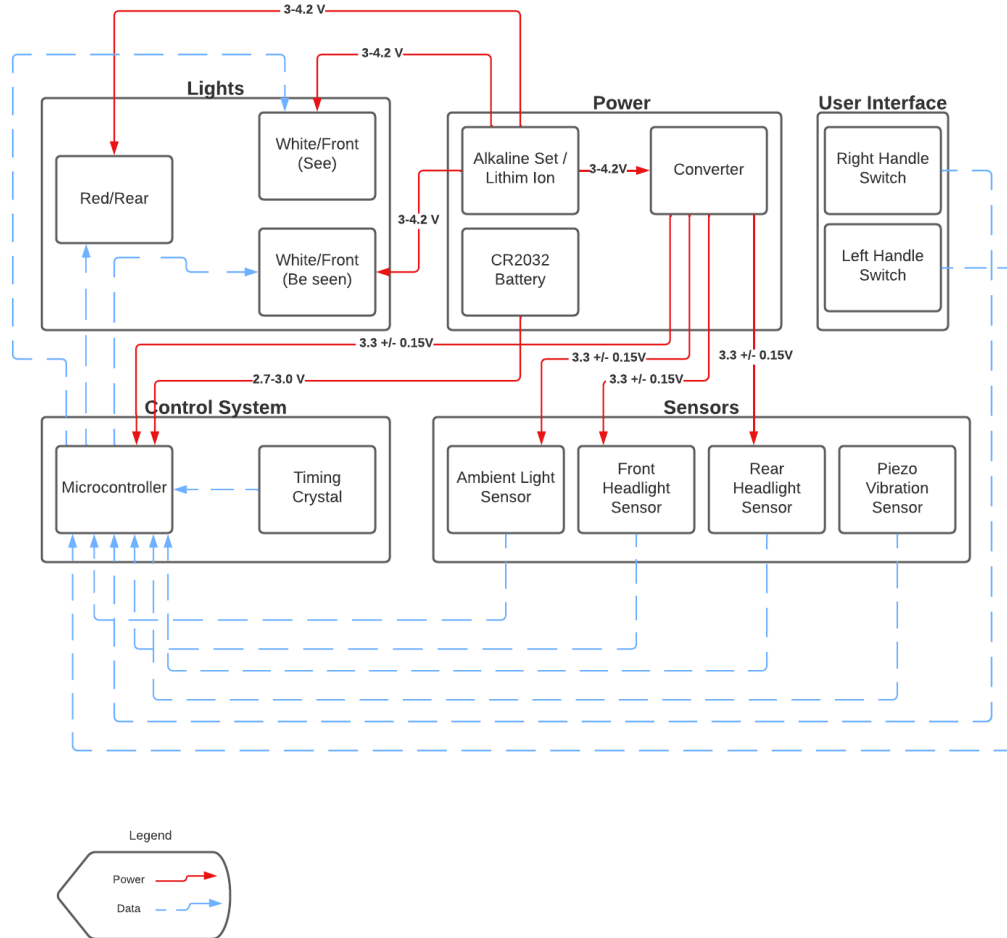

Figure 2: Automatic Bike Light System Block Diagram

The block diagram above shows the interactions between the main systems of our project. The power system provides power for all of the other systems, and due to the way our real time clock is implemented, it must have a backup battery. The primary battery is a large lithium ion battery pack, but when it is depleted, the microcontroller can be powered by a separate smaller battery in order to provide power while the main battery is being recharged. The lighting system is responsible for alerting nearby pedestrians and motorists of the bicyclist's presence. This is accomplished by a flashing white light on the front of the bike, and a flashing red light on the rear of the bike. The lighting system also has to be able to illuminate the road ahead, so there is a higher power LED array in the front to provide a steady light source. The lights are controlled by the microcontroller, which is responsible for interpreting data from the sensor system, maintaining a real time clock, and responding appropriately according to the inputs received from the

sensor systems. Finally, the sensor system as a whole is responsible for monitoring relevant conditions such as light levels, vibration, or user input, and sending that data to the microcontroller.

2.2 Physical Design

Besides the PCB, the only major physical design we have to do is designing the housing. Shown in figure 3 is the housing for the main PCB, battery pack, rear indicator, and rear headlight detection sensor. The PCB itself will be set into the indentation in the backing plate, shown in figure 4. The whole assembly will be held together with 4-6 screws, depending on how sturdy the initial prototypes feel. Larger images of the housing and backing plate are located in appendix A.



Figure 3: Rear module housing



Figure 4: Backing plate

2.3 Power System

The power system is responsible for making sure that all components receive the voltage and current that they need. The basis of our power system is a pair of 18650 lithium ion batteries connected in parallel. The decision to use rechargeable rather than primary cells was driven by the desire to reduce waste, and was supported by the ability of lithium ion cells to store enough energy to allow for more than 5 hours of continuous use between charges. Since the output voltage of the batteries varies based on the state of charge [2], provisions were necessary to avoid damaging sensitive electronic components. One option was to implement a master voltage regulator that would maintain a constant voltage out of the battery module, but this would have to be able to deliver upwards of one amp of current. This is not impossible, but it would be large and potentially expensive.

Instead, we specified as many components as possible with acceptable voltage inputs that include the direct output voltage of the batteries. The only systems that require voltage regulators are the photodetection systems because they use a voltage divider to set the reference voltage. Figure 5 shows the circuit schematic for the 3.3V converter contained within the front lighting and detection module. Because the converter is only powering

the comparator and providing a stable voltage for the voltage divider and switches, we only need one of them in the front module.

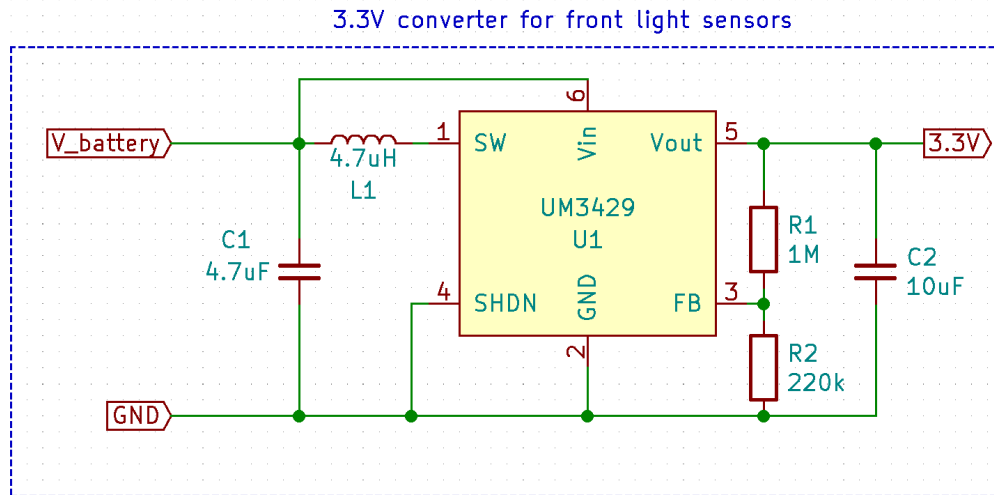

Figure 5: Front 3.3V converter

We also decided to regulate the voltage going into the microcontroller because the voltage on an input pin cannot exceed $V_{DD}+0.3V$. The output of the Li-Ion battery module will never drop below 3.0V when in use, and the photodetection circuits output up to 3.3V, so the voltage regulator is not completely necessary, but to avoid problems in the future, we decided to add the voltage regulator going into the microcontroller.

The second part of the power system is the backup CR2032 battery (figure 6). This battery is responsible for powering the microcontroller when the main battery module is either fully depleted or removed for charging. Maintaining a constant power supply for the microcontroller is necessary for the implementation of a real time clock. If the power supply to the microcontroller is interrupted for an extended period of time, then the real time clock will begin to fall behind. To address this, we added a small backup battery connected to only the microcontroller, which allows the real time clock to maintain time even when the main battery is removed. If the microcontroller input voltage falls below 2.7 volts, the schottky diode will begin conducting, and power will be restored to the microcontroller only. This will allow the time to be maintained on the real time clock.

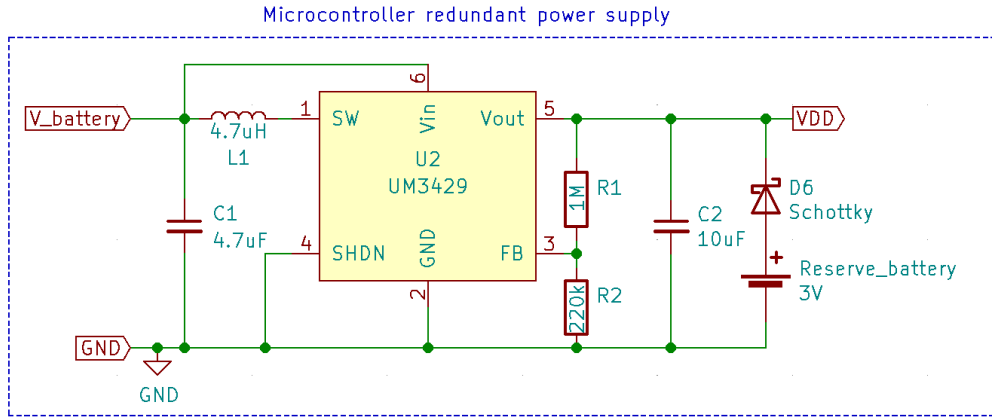

Figure 6: Microcontroller power supply with backup battery

Requirements	Verification
The converter must maintain an output voltage of $3.3 \pm 0.15V$.	With the Li-Ion battery providing an input voltage, a voltage differential probe on an oscilloscope will be used to measure the output voltage. The system passes if the output voltage remains within the acceptable range
Converter must remain under safe temperature conditions, under $100^{\circ}C$	During aforementioned voltage regulation test, use IR thermometer to monitor and chart component temperature. Ensure it does not exceed $100^{\circ}C$.
The microcontroller must maintain an output voltage greater than 1.8V, even in the event of the main battery being removed	Monitor the output voltage of the power supply in reference to ground, and disconnect the main battery. The system passes if the output voltage does not fall below 1.8V

Figure 7: Power system requirements and verification

2.4 Sensor System

2.4.1 Ambient Light sensor

The ambient light sensor is responsible for detecting how bright the surrounding environment is, and if it gets darker than a set value, it notifies the microcontroller that it may be appropriate to turn on the lighting system. The sensor utilizes a photodiode to directly detect the light levels, and the current produced by the photodiode is run through a resistor to produce a voltage. This voltage is then compared to a reference voltage from a voltage divider, and if the voltage from the voltage divider is greater than the voltage from the photodiode, the comparator outputs a logical high, which the microcontroller

detects. By using a potentiometer rather than a pair of fixed resistors in our voltage divider, we have the ability to tune the cut-off brightness by adjusting the potentiometer, rather than replacing individual resistors.

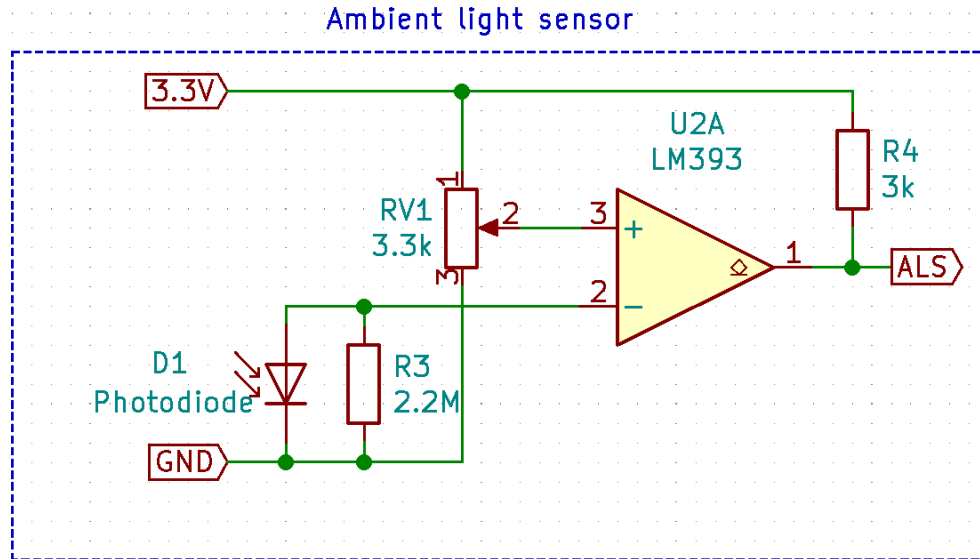

Figure 8: Ambient light sensor circuit

Requirements	Verification
<p>The ambient light sensor should change its output from a logical low to a logical high when the ambient light level falls below 500 lux.</p>	<p>Using the Light Meter LM-3000 iPhone app, verify that the light level in front of the ambient sensor is above 500 lux. Once this has been established, use a voltage differential probe on an oscilloscope to measure the comparator output voltage relative to ground. If the output voltage is less than 0.5V, continue to the next section. Turn off the lights, and verify with the iPhone app that the light level is below 500 lux. Once this is established, use the voltage differential probe to measure the comparator output voltage relative to ground again, and verify that the output voltage is greater than 3.0V. The system passes if it meets both requirements.</p>

Figure 9: Ambient light sensor requirements and verification

2.4.2 Headlight Detectors

The headlight detectors are identical to the ambient light sensor from an electronic hardware perspective. The only differences are the specific tuning of the potentiometer and the physical placement of the photodiode in the sensor housing. Where the ambient light sensor is located at the surface of the housing to give it as much light as possible, the headlight detectors are set into the housing to restrict the light that can reach the photodiode. By setting the photodiode at the back of a small tube, only rays of light that originated from nearly straight ahead can reach the photodiode. Light coming from sources overhead (street lights) or wide angles (porch lights) will not be able to reach the sensor. This allows the sensor to only detect light that comes from sources similar to a headlight.

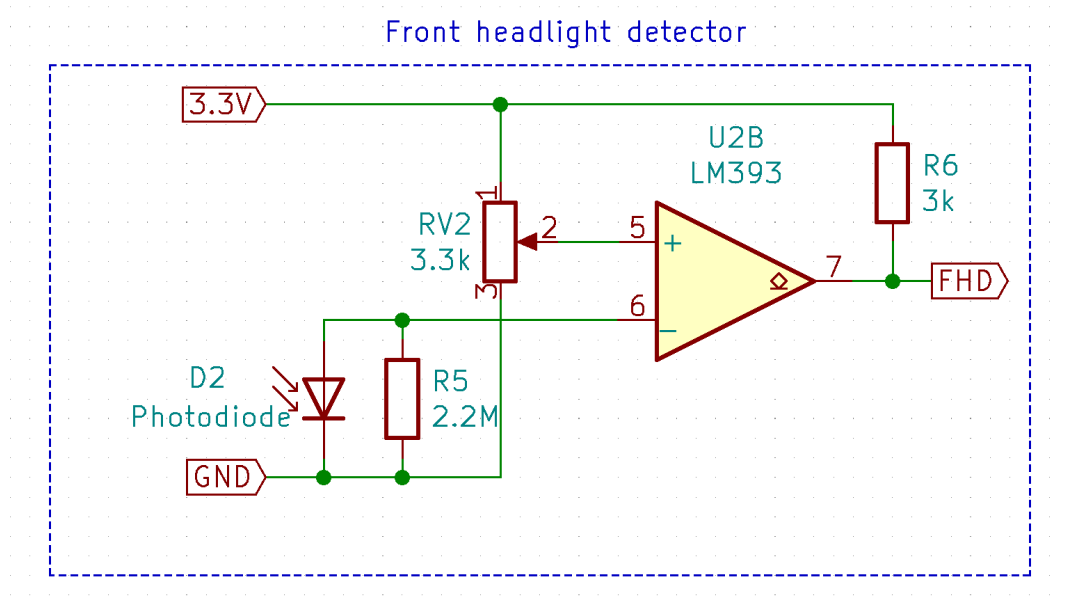

Figure 10: Front headlight detector

Requirements	Verification
<p>The headlight detection sensor should cause the indicator LEDs to increase in brightness if a car is detected within 30m.</p>	<p>In a fully dark parking lot (at least 1 hour after sunset, and as far away from any lights as possible), park a car 30m away from the front of the bicycle. Have one person remain in the car to turn the headlights (not the daytime running lights or the fog lights) on and off. With the front of the bike directly facing the car, note the brightness of the flashing indicators. Have someone turn on the headlights, and within 1 second, the indicators should flash brighter. Repeat this same process with the bike in the same place, but facing away from the car. The system passes if the headlights cause the indicators to become brighter in both test cases.</p>

Figure 11: Headlight detection sensor requirements and verification

2.4.3 Motion Detection Sensor

The motion detection sensor is just a piezoelectric film that is connected to an interrupt I/O port on the microcontroller. When the bicycle is moved, or in motion, the vibrations will cause the film to bend a small amount, which induces a voltage. This signal is sent to the microcontroller, and serves as an interrupt signal to wake the microcontroller out of its deep sleep mode.

The decision to use a piezoelectric film to detect motion rather than an accelerometer or other motion sensor came down to power consumption. Since this sensor has to always be on, minimizing its power consumption is critical to extending battery life. Since a piezoelectric element produces its own voltage, it does not need to consume any power to be monitoring for vibrations. All peripheral systems can be shut down, and the film will still send a signal to the microcontroller if it bends from a vibration. An accelerometer on the other hand would require a constant power supply, which would discharge the battery over time.

Requirements	Verification
<p>The motion detection sensor should activate the system within 15 seconds of the bicycle moving</p>	<p>Lock the bike onto a bike rack. Let the system go to sleep. At night, the system can be determined to be in sleep mode because the lights will be off. Once the system is asleep, unlock the bike, and remove it from the bike rack. Begin riding the bike, and within 15 seconds of riding, the lights should come on. If the lights come on within 15 seconds of riding, the system passes.</p>
<p>The motion detection sensor should put the system to sleep after 5 minutes of being stationary. Note: to avoid having to stand around for 5 minutes waiting for it to go to sleep, we will modify the software parameters to go to sleep after 30 seconds of inactivity. This is not practical in the real world, but demonstrates the system for our purposes.</p>	<p>Once the lights are on, put the bike back in the bike rack. Within 30 seconds of walking away, the lights should shut off. If they do so within the specified time, the system passes the test.</p>

Figure 12: Motion sensor requirements and verification

2.4.4 Handlebar Toggle Switches

The handlebar toggle switches are responsible for taking user input and sending it to the microcontroller. One switch is a main power switch. It will force the system into its deep sleep mode, regardless of what the sensors are saying is appropriate. The other state for that switch puts the sensors back in control of the system state. The second switch is used to toggle the headlight on and off. On well lit streets and bike paths, it may not be necessary to have the headlight on, so the user can turn it off to preserve the battery.

Requirements	Verification
<p>One of the toggle switches should force the system to sleep, regardless of the input from the ambient light sensor.</p>	<p>First, verify that the system is active by riding the bike in the dark to turn on the light system. Then, toggle the switch. The lights should turn off within one second. Once the system has turned off, toggle the switch back on, and within 15 seconds, the lights should turn back on. If the system turns off and back on, the switch passes the test.</p>
<p>The second toggle switch should turn on the headlight.</p>	<p>First, verify that the system is active by riding the bike in the dark to turn on the light system. Then, toggle the switch. The headlight should turn on within one second. Toggle the switch again, and the headlight should turn off. If the light turns on and off within the specified time, the switch passes the test.</p>

Figure 13: Toggle switch requirements and verification

2.5 Lighting System

2.5.1 Front Indicator

The front flashing indicator (Fig.[14]) is a set of 3 flashing white LED's placed on the front of the bike. They are necessary to alert cars and pedestrians in front of the bike that the bike is present. The LEDs are controlled by a current regulator, which is necessary to control the brightness of the LEDs. If the headlight detectors determine there is a car in front of the bike, the microcontroller can increase the brightness of the front indicator to get the attention of the driver. This control is also used to implement the flashing. Rather than having an RC circuit to produce the flash, the microcontroller varies the duty ratio of the control signal it sends to the current regulator. A duty ratio of zero will turn the light off, and a duty ratio that is not zero will turn it on. By adjusting the non-zero duty ratio, the brightness can be modulated in software.

2.5.2 Rear Indicator

The rear indicator is identical to the front indicator, except the lights are red and it goes on the back of the bike. The only difference from an electrical standpoint is the current limiting resistor value. Because the red LEDs we are using require more current than the white indicator LED's, the resistor has to be smaller.

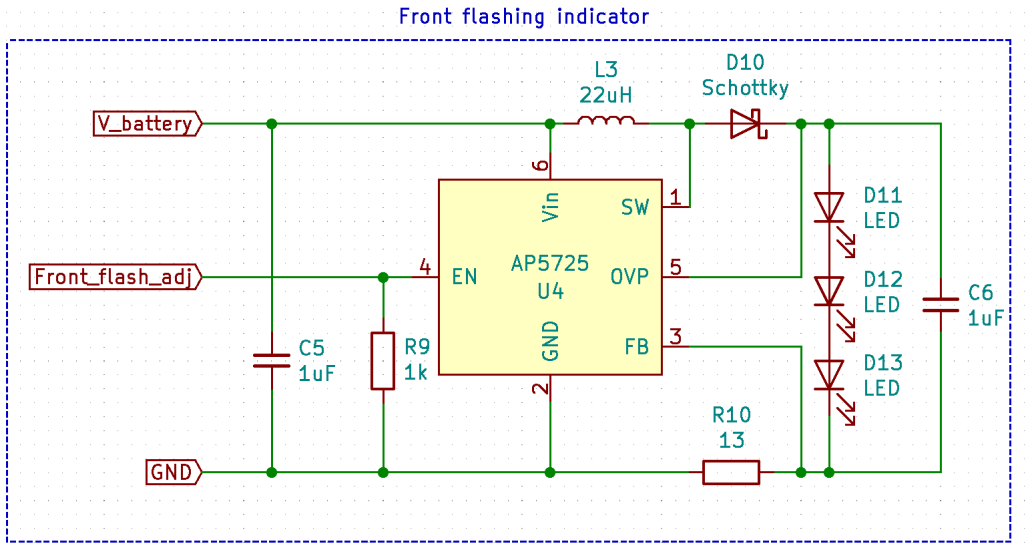

Figure 14: Front indicator light circuit

Requirements	Verification
The front indicator should be visible from 30 meters away from the bike.	Turn the light system on, and have someone stand 30 meters away from the bike. Verify that the indicator is visible. If it is, the system passes the test.
The rear indicator should be visible from 30 meters away from the bike.	Turn the light system on, and have someone stand 30 meters away from the bike. Verify that the indicator is visible. If it is, the system passes the test.

Figure 15: Indicator light requirements and verification

2.5.3 Front Headlight

The front headlight is a set of 6 white LED's that have to be capable of illuminating the road ahead enough to see potential hazards. To determine a target light output, we first found the light output of comparable bike lights to be 100-200 lumens [3]. We decided to aim for the brighter end of that range, with a target output of 200 lumens. The LED's are driven by another current regulator, which allows us to control the brightness in software, rather than hardware.

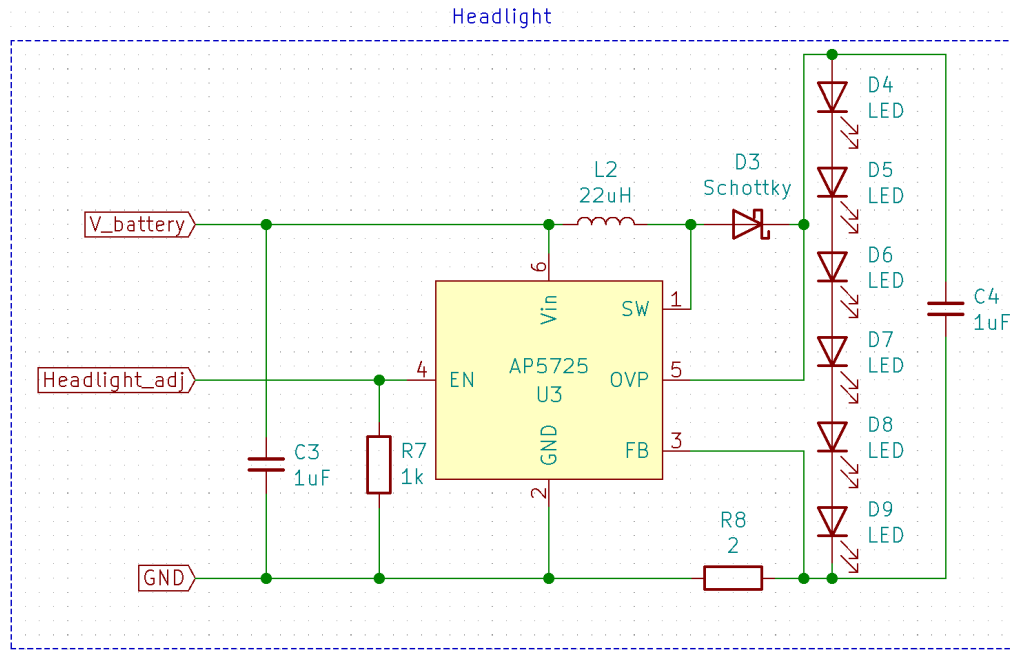

Figure 16: Headlight circuit schematic

Requirements	Verification
The headlight should output enough light to measure 50 lux from 20 feet away.	Use the "peak" measurement mode on the Light Meter LM-3000 iPhone app to measure the light output. Place the phone on the ground, 20 feet directly in front of the bike. Turn on the headlight, and leave it on for 5 seconds. After 5 seconds has elapsed, turn the light off, and record the peak intensity recorded by the app. If the value is at least 50 lux, the light passes the test.

Figure 17: Headlight requirements and verification

2.6 Microcontroller

The microcontroller is responsible for activating and modulating the lights, maintaining a real time clock, and interpreting data coming from the various sensors. Additionally, it must consume as little power as possible to extend the life of the battery. To accomplish all of these goals, we selected a PIC18F27Q43 microcontroller. This particular controller was appealing due to the large number of I/O ports, low cost, and its low power sleep mode. When the system does not need to be active, the microcontroller can shut down its peripheral systems, as well as the other systems within our project. In doing so, the power consumption of the entire automatic lighting system is essentially zero.

Shown in figure 18 is the microcontroller, the circuitry required to operate and program it, the real time clock crystal, and the pin functionality for all of the pins. At the top is the connector used to program the microcontroller while it is still connected to our project. All of these connections are dictated by the data sheet that comes with the controller. The crystal for the real time clock is on the bottom left corner of the controller, and to reduce the risk of electronic interference, the pins near it are not going to be used. The right side of the controller contains most of the I/O pins for interacting with other systems. Once all of these pins had been assigned, we had several pins leftover. Rather than just leaving them not connected and driving them to a logical low, we decided to add a connector to 5 of the unused pins to give us a set of pins that we can use to either add additional functionality to the system, or for debugging purposes.

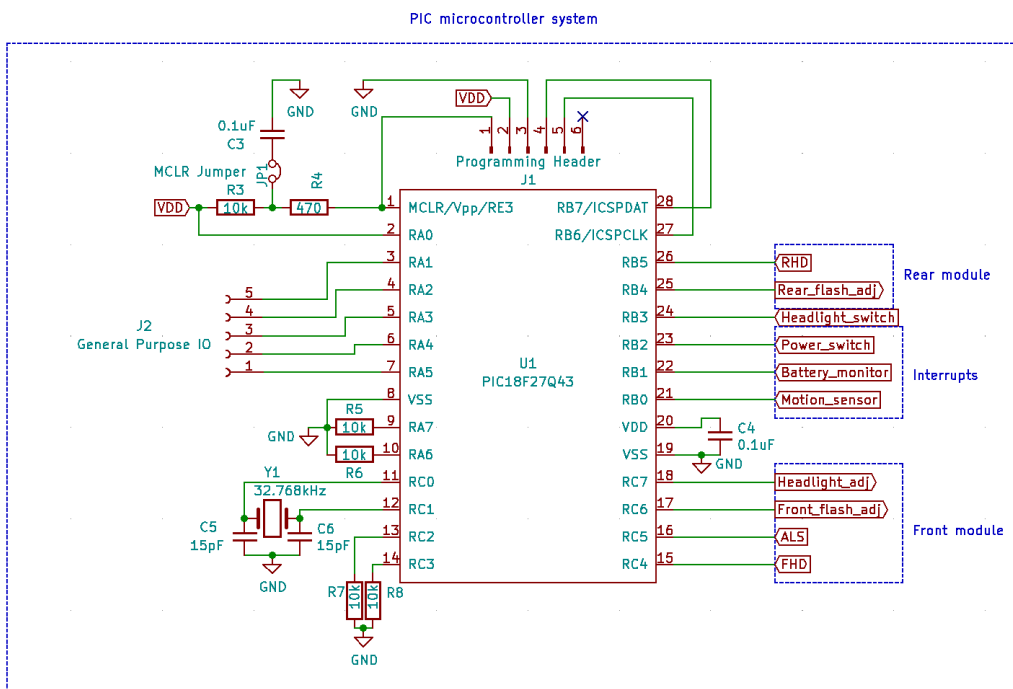

Figure 18: Microcontroller schematic

Requirements	Verification
The microcontroller should be able to activate all functions over which it has control.	If all systems except for the power system pass their requirement and verification tests, then the microcontroller is fully functional.

Figure 19: Microcontroller requirements and verification

2.7 Tolerance Analysis

Due to changes in our design since the project proposal, there is now a critical tolerance in our system. The output of our photodetection circuit is limited to the output voltage of the 3.3V converter. That signal is then sent to the microcontroller, which can only accept voltages up to 0.3V greater than its own input voltage. Since its supply voltage is 3.3V from an identical 3.3V converter, the tolerances on the outputs of both converters will be the same. Therefore, the tolerance on both converter outputs is $\pm 0.15V$. If the output of the photodetection circuit converter is at the top of this tolerance (3.45V) and the output of the microcontroller converter is at the bottom of this range (3.15V), then the difference between them is exactly 0.3V, and the controller can still accept the input without being damaged.

Additionally, the current limiting resistors used in our LED drivers must be chosen carefully, as the tolerances are safe on one side of the specification, but not on the other. The LEDs are all rated for a current provided on the data sheet, and we do not want to exceed this value, as it will shorten their life span. Calculating the necessary resistor is done via Ohm's law, but the calculated values are not always available, so we had to pick a resistor that is close to the calculated value, but will not allow too much current to flow. To compensate for this, we reduced the current value we used in the calculation by a small amount, and also chose the next available size resistor if it did not come out to a clean value.

3 Cost and Schedule

3.1 Cost Analysis

3.1.1 Labor

We are going to assume a wage of \$40 per hour for each team member and assume we spend 15 hours a week working for 9 weeks.

$\$40 \text{ per hour} \times 15 \text{ hours} \times 9 \text{ weeks} \times 3 \text{ people} = \$16,200$

We estimate the total cost of labor for the project to be \$16,200.

3.1.2 Parts

We do not expect to use the machine shop for our project and as a result have excluded that information from the parts table. Tools such as soldering equipment and oscilloscopes that may be needed throughout the project are either already on hand or can be found in the senior design lab.

Description	Manufacturer	Supplier	Supplier Part #	Quantity	Cost
CR2032 Backup Battery	—	—	—	1	\$0
354 Main Battery Pack	Adafruit Industries LLC	Digikey	1528-1834-ND	1	\$19.95
USB LiIon/LiPoly Battery Charger	Adafruit Industries LLC	Adafruit	259	1	\$12.50
PIC18F27Q43-I/SP Microcontroller	Microchip Technology	Digikey	150-PIC18F27Q43-I/SP-ND	2	\$4.94
ED281DT DIP Socket	On Shore Technology Inc.	Digikey	ED3050-5-ND	3	\$1.11
R38-32.768-12.5-EXT-5PPM Tuning Fork Crystal	Raltron Electronics	Digikey	2151-R38-32.768-12.5-EXT-5PPM-ND	2	\$0.32
885012008038 15 pF Capacitor	Würth Elektronik	Digikey	732-7882-2-ND	4	\$0.44
VTP9812FH Radial Photodiode	Excelitas Technologies	Digikey	VTP9812FH-ND	2	\$1.34
AP3012KTR-G1 Step-Up DC-DC Converter	Diodes Incorporated	Digikey	AP3012KTR-G1DITR-ND	1	\$0.49
CFR-25JB-52-2M4 2.4 MOhm Resistor	YAGEO	Digikey	2.4MQBK-ND	1	\$0.10
PV36W105C01B00 1 MOhm Potentiometer	Bourns Inc.	Digikey	490-2877-ND	1	\$1.47
LM393PE3 CMOS Differential Comparator	Texas Instruments	Digikey	296-49723-ND	4	\$1.68
ICS-308-T IC Socket	Adam Tech	Digikey	2057-ICS-308-T-ND	10	\$1.41
MSP1006-ND Piezoelectric Vibration Sensor	TE Connectivity Measurement Specialties	Digikey	MSP1006-ND	1	\$6.77
LW514 White LED	Seoul Semiconductor Inc.	Digikey	897-1069-1-ND	5	\$3.45
VLC55130 Red LED	Vishay Semiconductor Opto Division	Digikey	VLC55130-ND	5	\$2.90
High Power LED White	Würth Elektronik	Mouser	710-158563460	10	\$4.63
AP5725WG-7 LED Step-Up Driver	Diodes Incorporated	Digikey	AP5725WG-7DITR-ND	5	\$3.15
RES 10K OHM 1/4W AXIAL	Stackpole Electronics Inc	Digikey	CF14JT10K0TR-ND	10	\$0.56
RES 2 OHM 1/4W AXIAL	Stackpole Electronics Inc	Digikey	RNF14FTD2R00TR-ND	1	\$0.17
RES 13 OHM 1/4W AXIAL	Stackpole Electronics Inc	Digikey	13.0XBK-ND	1	\$0.10
RES 5.6 OHM 1/4W AXIAL	Stackpole Electronics Inc	Digikey	13-MFR-25FTE52-5R6CT-ND	1	\$0.15
RES 2.2M OHM 1/2W AXIAL	Stackpole Electronics Inc	Digikey	CF12JT2M20TR-ND	3	\$0.30
RES 3K OHM 1/4W AXIAL	Stackpole Electronics Inc	Digikey	CF14JT3K00TR-ND	3	\$0.30
RES 470 OHM 1/4W AXIAL	Stackpole Electronics Inc	Digikey	CF14JT470RCT-ND	1	\$0.10
CAP CER 4.7UF 25V X5R RADIAL	TDK Corporation	Digikey	445-173577-1-ND	2	\$0.82
CAP CER 10UF 25V X5R RADIAL	TDK Corporation	Digikey	445-181284-1-ND	2	\$1.10
CAP CER 1UF 25V X7R RADIAL	TDK Corporation	Digikey	445-173583-1-ND	6	\$1.10
CAP CER 0.1UF 50V Z5U RADIAL	KEMET Corporation	Digikey	399-4151-ND	2	\$0.46
FIXED IND 4.7UH 1.3A 90 MOHM TH	Murata Power Solutions Inc.	Digikey	811-2022-ND	2	\$0.5
FIXED IND 22UH 410MA 900 MOHM TH	Bourns Inc.	Digikey	77F220K-TR-RCTR-ND	3	\$0.96
RECEPTACLE, THR, DUAL ROW, .100"	METZ CONNECT USA Inc.	Digikey	1849-FR20204HBDN-ND	2	\$1.5
RECEPTACLE STRIP 5P 2.54MM PITCH	Adam Tech	Digikey	2057-RS1-05-G-ND	1	\$0.41
CONN HEADER VERT 6POS 2MM	METZ CONNECT USA Inc.	Digikey	1849-1001-ND	1	\$0.19
CONN HEADER VERT 8POS 2.54MM	Adam Tech	Digikey	2057-PH2-08-UA-ND	2	\$0.34
STEP UP DC DC CONVERTER	Union Semiconductor (HK) Limited	Digikey	3351-UM3429STR-ND	2	\$3.34
IC LED DRIVER RGLTR DIM SOT26	Diodes Incorporated	Digikey	AP5725WG-7DITR-ND	3	\$1.89
TRIMMER 3.3K OHM 0.5W PC PIN TOP	Bourns Inc.	Digikey	3296W-1-332LF-ND	3	\$9.09

Total Parts Price: \$90.32

Figure 20: Components and pricing

Grand Total: \$16,200 (Labor Costs) + \$90.32 (Total Parts Price) = \$16,290.32

3.2 Schedule

Week	Neeraj	Jeremy	Brian
2/21	Order Parts	Finish Design Document	Finish Design Document
2/28	Prep for Design Review	Begin Programming Microcontroller	Finalize PCB Layout for Review
3/7	Validate Ordered Parts	Finish Programming Microcontroller	Order Prototype PCB
3/14	Spring Break	Spring Break	Spring Break
3/21	Assemble Lighting Subsystem	Design and Print Enclosures	Evaluate Prototype PCB, Order Update
3/28	Solder PCB	Assemble Sensor Subsystem	Assemble New PCB
4/4	Calibrate Sensor Subsystem	Debug Microcontroller	Test Completed Systems
4/11	Debug Faulty Subsystems	Combine Assembled Subsystems on Bicycle	Debug Faulty Subsystems
4/18	Start Final Paper	Start Final Presentation	Work on Final Demonstration
4/25	Finish Final Paper	Finish Final Paper	Finalize Presentation

Figure 21: Schedule

4 Discussion of Ethics and Safety

4.1 Potential Ethical and Safety Issues

One of the biggest safety concerns that this project poses is a safety concern inherent to all bike lights; whether or not it will warn the user when the battery is low, potentially leaving the user with a non-functioning light without warning. This is especially dangerous in low-light conditions which could leave the rider in a dangerous situation where they can't see the path ahead of them, increasing the risk of injury and accident. To ensure the safety of the cyclist, we intend to implement a power indicator to warn the user when the system is in danger of shutting off the lights entirely. Putting the power indicator somewhere that is easy to see should ensure that the rider knows when it is time to charge the system and when it may be unsafe to take a longer ride.

There are also safety concerns that must be addressed with any system that utilizes lithium-ion batteries. Since our product requires a mobile power source, we have decided that rechargeable batteries offer a solution to this problem and have the added benefit of being cheaper to have over the long run compared to buying new replacement batteries once the ones in use lose charge. Although our system will not be demanding power from the battery module at a level that could cause a risk of fire, we need to still be careful and ensure that the batteries are enclosed in a waterproof container to mitigate the inherent risks associated with batteries[4]. In order to prioritize safety, we are going to use off-the-shelf solutions with the battery and charger where possible, given that these products are rigorously tested to meet safety standards.

As for ethical concerns concerning the project, there is nothing that is particularly outstanding given the nature of this project. Referring to both the IEEE and ACM codes of ethics, the only thing that is relevant to our project is a commitment to sustainability mentioned in the IEEE Code of Ethics[5]. We commit ourselves to sustainability by making the choice to use rechargeable batteries rather than non-rechargeable ones, which should reduce the environmental impact our product has. Lithium-ion batteries must be recycled or disposed of separately from normal waste [6], so by eliminating the need for the users of our product to handle such responsibility we make a small yet important effort towards being ethical in our design and considering the environmental impact of our creation.

References

- [1] Y. Kishida. "Changes in Light Intensity at Twilight and Estimation of the Biological Photoperiod." (1989), [Online]. Available: https://www.jircas.go.jp/sites/default/files/publication/jarq/22-4-247-252_0.pdf (visited on 02/21/2022).
- [2] SWE. "Lithium-Ion Information Guide." (Unknown), [Online]. Available: <https://www.swe.com/lithiumion/> (visited on 02/20/2022).
- [3] R. Annis. "A Quick Guide to Lighting Up Your Bike." (2013), [Online]. Available: <https://www.popularmechanics.com/adventure/sports/a9469/a-quick-guide-to-lighting-up-your-bike-15997921/> (visited on 02/20/2022).
- [4] U. E. 4. S. 2. C. Staff. "Safe Practice for Lead Acid and Lithium Batteries." (2016), [Online]. Available: <https://courses.engr.illinois.edu/ece445/documents/GeneralBatterySafety.pdf> (visited on 02/20/2022).
- [5] IEEE. ""IEEE Code of Ethics"." (2016), [Online]. Available: <https://www.ieee.org/about/corporate/governance/p7-8.html> (visited on 02/21/2022).
- [6] U. S. E. P. Agency. "Used Lithium-Ion Batteries." (2021), [Online]. Available: <https://www.epa.gov/recycle/used-lithium-ion-batteries> (visited on 02/20/2022).

Appendix A Expanded views of module housings



Figure 22: Housing for the rear module

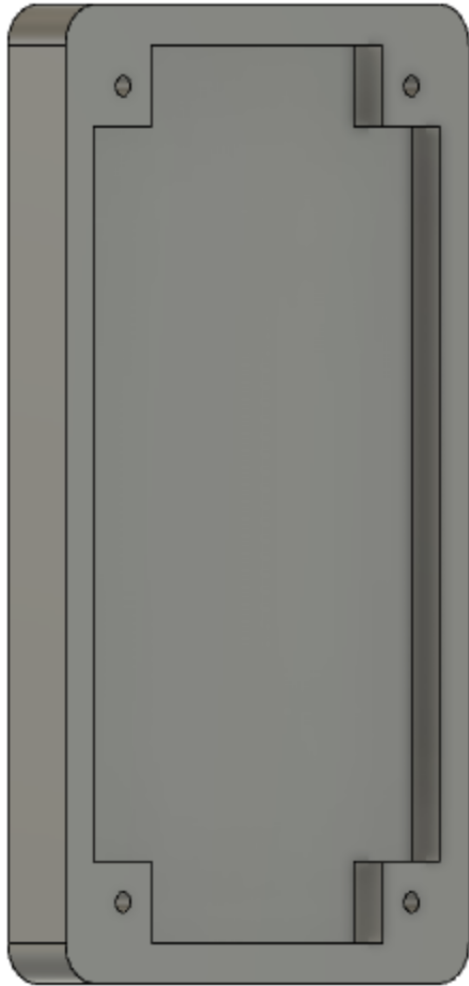

Figure 23: Backing plate for the rear module