

ECE 445 Spring 2020 Design Document

Blue Light–Tracking Glasses

Team 3: Erik Lundin [erikjL2], David Yan [davidzy2], Jane
Zhao [janejz2]
TA: Charles Ross

Responsibilities:

Erik: Sensor Module

David: Timer Module & User Interface Module

Jane: Power Module & Control Logic Module

1. Introduction

1.1 Objective

Since its inception, artificial light has changed the world dramatically: it has allowed humans to function in environments without sunlight, providing us with the opportunity to function effectively during the night or in enclosed spaces, and in modern times it has given us the ability to view and communicate complex visual information, making concepts such as television and computer displays possible. However, the development of modern artificial lighting has far outpaced the evolution of human beings' mechanisms for sleep regulation. In the last three decades, research on the impact of light pollution has demonstrated that exposure to shorter wavelengths of visible light can disrupt the human circadian rhythm¹ through suppression of melatonin² secretion [1]. Specifically, two pioneering studies by Brainard et al. [2] and Thapan et al. [3] on the action spectrum of melatonin suppression showed that maximum melatonin suppression from artificial light occurs at wavelengths of 446-477 nm; in other words, exposure to blue light alters hormone secretion, which can interfere with our sleep cycle. This interference is particularly significant when blue light exposure occurs in the evening: as little as 2 hours of night-time blue light exposure is enough to suppress melatonin [1]. Long-term night-time blue light exposure that leads to disruptions in our circadian rhythm is associated with higher incidences of cancer, diabetes, mental health disorders, age-related macular degeneration, and obesity [1], [4]. Therefore, night-time blue light exposure is a public health issue that has implications not only for workplace standards, but also for our daily lives.

In order to address this issue, we propose to develop a device known as Blue Light-Tracking Glasses, which would allow members of the public to limit the extent of night-time³ blue light exposure in their daily lives without the need for expensive and clunky instrumentation, and in a way that most closely accounts for the actual light that is reaching their eyes. The device would therefore be used in the evening to measure a user-set time limit of blue light exposure (2 hours or less given the above information) and would alert the user when this time has been reached. A photo-sensing circuit located near the lateral rim of the glasses will specifically detect blue light incident on the sensor. When the device is turned on, the user will simply set an alarm to indicate when a certain exposure time has been exceeded, at which point an LED indicator will turn on. These glasses will be light enough to wear comfortably, and will be electrically insulated to protect the user. Compared to alternative methods of solving the problem of blue light exposure, our device is unique because it does not filter out light from or change the light spectrum of the environment.

¹ A term collectively referring to the endogenous processes regulating our internal physiological state that cycle within a 24-hour time period.

² A hormone that positively regulates sleep in the body.

³ Here we define night-time as any time after sunset and before sunrise, which is relevant because there is no sunlight in this period of time, and it is sunlight that regulates biological sleep. Previously cited studies may have different definitions.

1.2 Background

Blue light (380-500 nm⁴) exposure can cause oxidative damage in the cornea, degeneration of the retina, and alteration of the circadian rhythm [5], [6], [7]. However, although blue light alters circadian rhythm, it is not always detrimental; in fact, blue light is beneficial in regulating the circadian rhythm when exposure occurs in the daytime [8]. Only evening blue light exposure has negative effects on sleep regulation due to its suppression of melatonin secretion and the associated induction of cortisol secretion, which effectively keeps the body physiologically “awake,” thereby affecting sleep quality and potentially causing daytime fatigue [5], [7]. Thus, in addition to concerns about short wavelength light causing direct damage to parts of the eye, public health concerns are also warranted for the use of blue light emitting devices at night.

While sunlight is the major source of blue light in our lives, LED lights, fluorescent bulbs, and electronic displays containing LED lights also emit blue light, and the length of time and proximity at which we are exposed to these sources of light can potentially be harmful [7]. Generally, the medical consensus is that people should avoid or limit exposure to blue light in the few hours before going to sleep [9]. Besides limiting exposure, other available solutions to this problem are blue light-filtering glasses and electronic display color-shifts. Blue light-filtering glasses are glasses that have lenses that specifically block out high-energy visible light using reflective coatings: example products include Quay Australia’s “BLUE LIGHT Computer Glasses” [10] and Blokz™ Blue Light Lenses [11]. A color-shift in an electronic display refers to the ability to reduce the amount of blue light emitted from the display by changing its emission spectrum. Common examples include “Night Light” on Windows 10 and “Night Shift” on MacOS operated computers [12].

The Mayo Clinic Health System as well as Harvard Health both list blue light-filtering glasses as a way to help prevent digital eye strain and reduce night-time blue light exposure (in order to improve sleep quality) [9], [13]. However, these glasses show no significant clinical efficacy against digital eye strain [14]. Consequently, the American Academy of Ophthalmology states that they “do not recommend any special eyewear for computer use,” a subtle but firm rebuke [15]. Regarding the improvement of sleep quality, participants in multiple clinical trials who wore blue light-filtering glasses reported no significant changes in subjective sleep quality, though no objective measurements of melatonin levels were taken [16], [17]. In contrast, a separate study reported that users wearing blue light-filtering glasses experienced increased melatonin secretion and improved subjective sleep quality [18]—which is the expected result given the relationship between blue light and melatonin secretion. As for the color-shift on computers, the Night Shift on an iPhone 7 could already reduce activation of melanopsin⁵ by 67% [19]. Free software called “f.lux” that automatically shifts your computer display to warm colors at night has been shown to significantly improve subjective sleep quality in night shift workers [20]. Although there are mixed results on the effects of blue light-filtering glasses, the objective measurements of circadian rhythm (i.e. melatonin levels) indicate that blue light-filtering

⁴ High-energy visible light wavelength range. Commonly referred to as ‘blue light’. Blue-violet extends from 380-450 nm, while true blue light ranges from 450-485 nm [6], [7].

⁵ Photodetector molecule involved in blue light-induced suppression of melatonin secretion.

glasses and color-shifts in electronic displays are both able to reduce the alteration in sleep regulation from blue light at night.

Considering the extent of research completed and the efficacy of available products, the solutions to the problem of blue light exposure at night—including completely avoiding blue light exposure, wearing blue light-filtering glasses, or using a color-shift on electronic displays—seem to be well developed and readily accessible to the public. However, we believe that the one flaw among the provided solutions is that besides not being able to work at all for the case of complete avoidance of blue light exposure, the latter two solutions (filtering glasses and color-shift) do not allow us to work on color-sensitive work at night because they filter out some of the visual information coming from the environment. Perhaps someone needs to accurately distinguish between certain colors in a graphic design; to control an airplane while seated in the cockpit; or to monitor process feedback on electronic displays in a factory.

Not every type of blue light source can be filtered at the display level, and some applications cannot tolerate removal of blue light from the spectrum. Indeed, some people certainly would not enjoy their movie as much if they had to shift the colors to favor one side of the spectrum. Thus, a niche product audience can be found among people who are conscientious about their health and long-term sleep quality but who do not want to filter out light from their environments. This warrants a device like our Blue Light–Tracking Glasses, which are able to detect blue light in the environment and assist users in setting exposure time limits, but which do not filter the light out. The closest existing product to our device is a patented smart wristwatch that can detect blue light and alert a user via textual notification [21]; still, our Blue Light–Tracking Glasses device is more applicable and more elegant in that it most accurately resembles measurement of light that actually hits your eyes (as opposed to light which hits your wrist) and that it simply turns on an LED to alert the user that the blue light exposure time limit has been reached (rather than textual notification).

1.3 Visual Aid

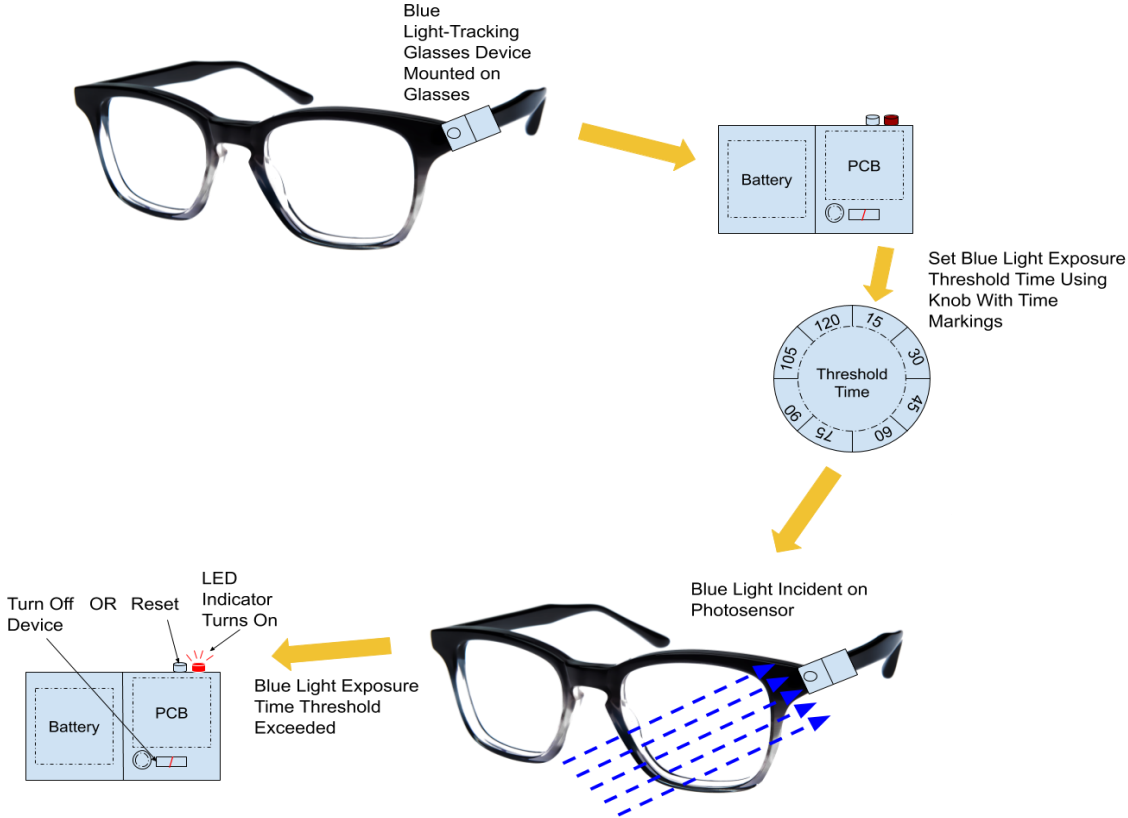

Figure 1. Visual Aid for Blue Light Tracking Glasses Showing Typical Usage of the Device.

1.4 High Level Requirements

- Device is able to detect blue light (380-500 nm) incident on its photosensor of intensity higher than $150 \mu\text{W}/\text{cm}^2$ which is known to negatively impact health.
- Device should be less than 30 cm^2 in area and weigh less than 60 g.
- Device users can set a time limit of 2 hours or less (in 15 minute increments, with an accuracy of ± 5 minutes) of blue light exposure and should be notified when blue light exposure time has exceeded the user-set time threshold while the device is in use.

2. Design

2.1 Overview

Our device will primarily be implemented on a single PCB containing all of our photo-sensing circuitry. Blue light detection will occur in the device's Sensor Module, which contains a photodiode with a high responsivity in the blue light band of the visible light spectrum, along with an external dichroic filter that will remove light of longer wavelengths before it impinges on the photodiode. The photodiode will be run in photoconductive mode; therefore, a transimpedance amplifier will be necessary to convert the photocurrent into a voltage that matches the voltage requirements of subsequent modules. This voltage output from the transimpedance amplifier will be fed into a Non-inverting Schmitt Trigger in order to output a logical 1 when the amplifier voltage is above a certain threshold, indicating that harmful blue light exposure conditions have been met. The resulting digital signal, which is called BLUE_EXPOSURE, will be sent to the Control Logic module, which by using this signal will ultimately enable the Timing Module to record the duration of the blue light exposure.

In the Control Logic Module, the BLUE_EXPOSURE signal is inputted into the equivalent of a 3-input AND gate, which sends its output into the clock input pin of the counter in the Timing Module. The other two inputs of the AND gate are the output of an oscillator in the Timing Module, and the inverted output of the 24th bit of the counter (24th bit is INDICATOR, inverted 24th bit is \sim INDICATOR). Initially, the counter starts from zero, so the inverted output of the 24th bit is a logical 1. Thus, the only two signals that determine the output of the AND gate are the oscillator output and the BLUE_EXPOSURE signal. When BLUE_EXPOSURE is high, the oscillator output is directly translated to the output of the AND gate. Since the AND gate output is connected to the clock input of the counter, the result is that the counter is clocked at the frequency of the output of the oscillator. Therefore, the BLUE_EXPOSURE signal having the value of logical 1 effectively enables the counter to begin counting at the frequency of the oscillator; whereas when BLUE_EXPOSURE is low (logical 0), the counter is paused (clock input is driven to logical 0).

At a fixed value of 2^{23} counts (when the counter's 24th bit is high), the counter will then turn on an LED in the Indicator Subsystem, thus indicating to the user that the blue light exposure time threshold has been reached. After the exposure time threshold has been reached, the counter is paused, and the user can then press the reset button in the User Interface Module to restart the counter and turn off the indicator LED, thereby resetting the timing functionality of the circuit. The counter will be paused at the exposure time threshold because one of the inputs to the AND gate which controls the clock input of the counter is the \sim INDICATOR signal (outputted from the Control Logic Module), or the inverted output of the 24th bit of the counter. When the exposure time threshold has been reached, the 24th bit of the counter is high, and \sim INDICATOR signal is low, causing the AND gate controlling the clock input of the counter to be driven to logical 0, which effectively pauses the counter. Additionally, the \sim INDICATOR signal is active low in terms of its functionality to turn on the LED. Thus, when the counter is reset, the 24th bit is reset to 0, \sim INDICATOR is logical 1, and the LED is turned off automatically.

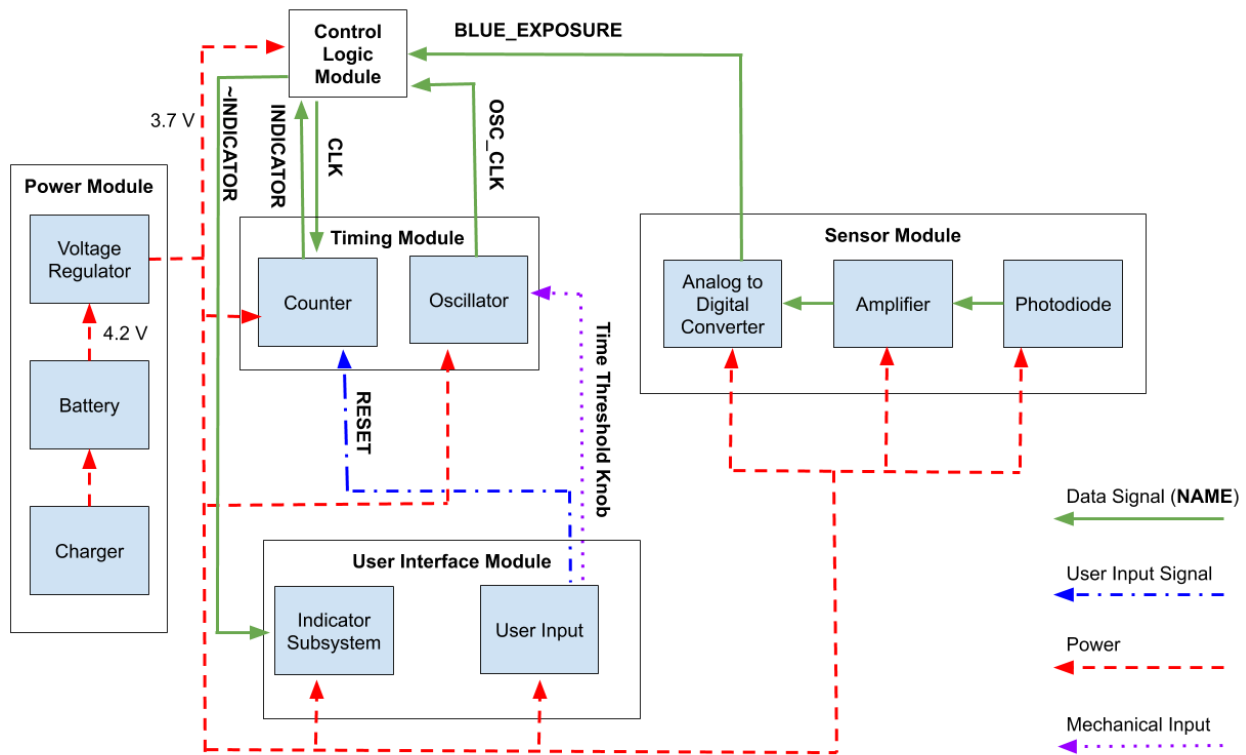

Figure 2. Block Diagram of Circuit in Blue Light-Tracking Glasses.

In order to set different exposure time thresholds, the user will be able to change the oscillation frequency of the oscillator that generates the clock signal for the counter. A change in the frequency of the clock would cause faster or slower counting of the counter, and since the counter sets off the indicator LED at a fixed counter value, this would allow different time thresholds to be achieved. The user can change the oscillation frequency of the oscillator by turning the knob of a variable resistor that is part of an RC circuit that controls the oscillator’s frequency. Using this knob, the user will be able to set the oscillator to frequencies corresponding to time thresholds of 15 minutes to 2 hours, with 15 minute increments marked on the knob.

Lastly, the Power Module will output a continuous 3.7V to all necessary modules for an operation time of at least 6 hours. Overall, the above circuit components collectively allow the user of Blue Light-Tracking Glasses to set a time limit on blue light exposure, to be notified when the exposure time limit has been reached, and to reuse the device multiple times in one sitting or on multiple occasions after the device has been powered off in between uses.

2.2 Physical Design

The physical design will consist of a small case (rectangular prism-shaped housing) that will house the battery and the PCB, which itself will contain all circuit components shown in Figure 2. The case will be able to be mounted on glasses, and will have cutouts for the photodiode, indicator LED, power switch, reset button, time threshold knob and charging port.

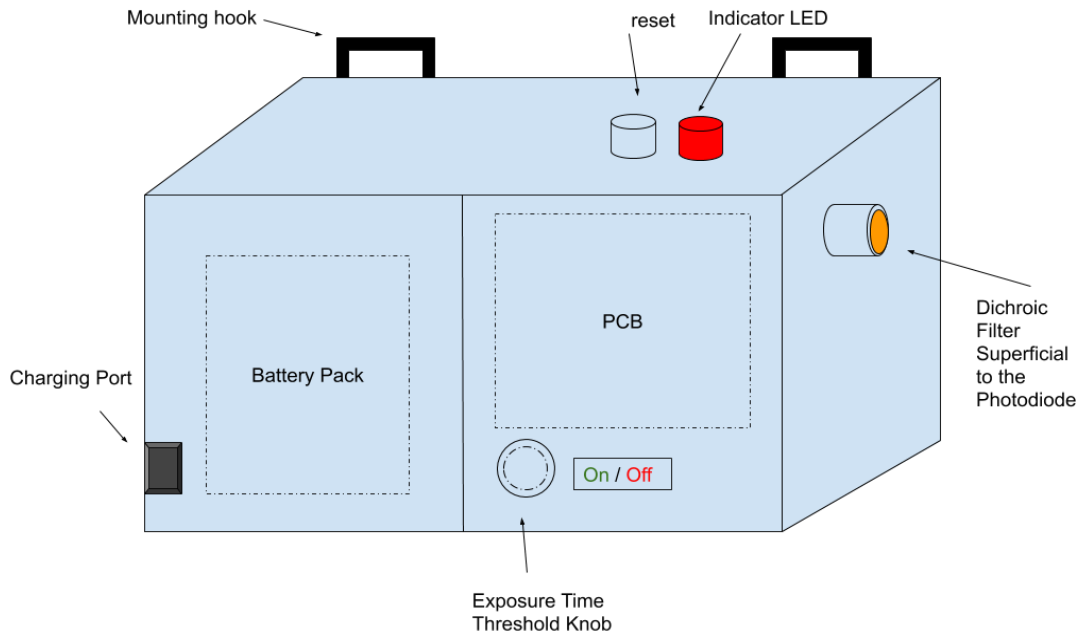

Figure 3. Physical Design Sketch of External Housing of Blue Light-Tracking Glasses Circuit.

2.3 Sensor Module

This module will detect the blue-light (380-500 nm) incident on the photodiode that will be facing anteriorly and will be located near the user's face. It will consist of a photodiode, amplifier and analog to digital converter. A dichroic filter will be used to initially filter the light to prevent any false positives from larger wavelengths that may yield sufficient photocurrent from the photodiode. The photodiode will be run in photoconductive mode so a transimpedance amplifier is needed to convert the small μA photocurrent to a usable voltage between 0.1 V and 3.7 V. A Non-inverting Schmitt Trigger will be used to convert this voltage range into a logical 0 or 1 for use in the Control Logic Module.

2.3.1 Photodiode

The Excelitas Technologies VTB8441BH [22] photodiode will be used to detect blue light and output a photocurrent. This photodiode was chosen primarily for its high responsivity around blue-light (380-500 nm) shown in Figure 4. The photodiode has large active area of 5.16 mm^2 which allows more power to be incident on the device, yielding a higher photocurrent. This photodiode also has a dark current of 2000 pA which is not a significant amount compared to the photocurrent we are planning on detecting (see requirements). The photodiode will be used in photoconductive mode so that the photocurrent is proportional to the power incident on the device. The current will then be transformed into a usable voltage output through a transimpedance amplifier. The expected photocurrent at the threshold power of $150 \mu\text{W}/\text{cm}^2$ (chosen based on [1]) will be around $1.5 \mu\text{A}$ assuming an average responsivity of 0.2 A/W in this bandwidth.

Absolute Spectral Response "B" Series (Filtered)

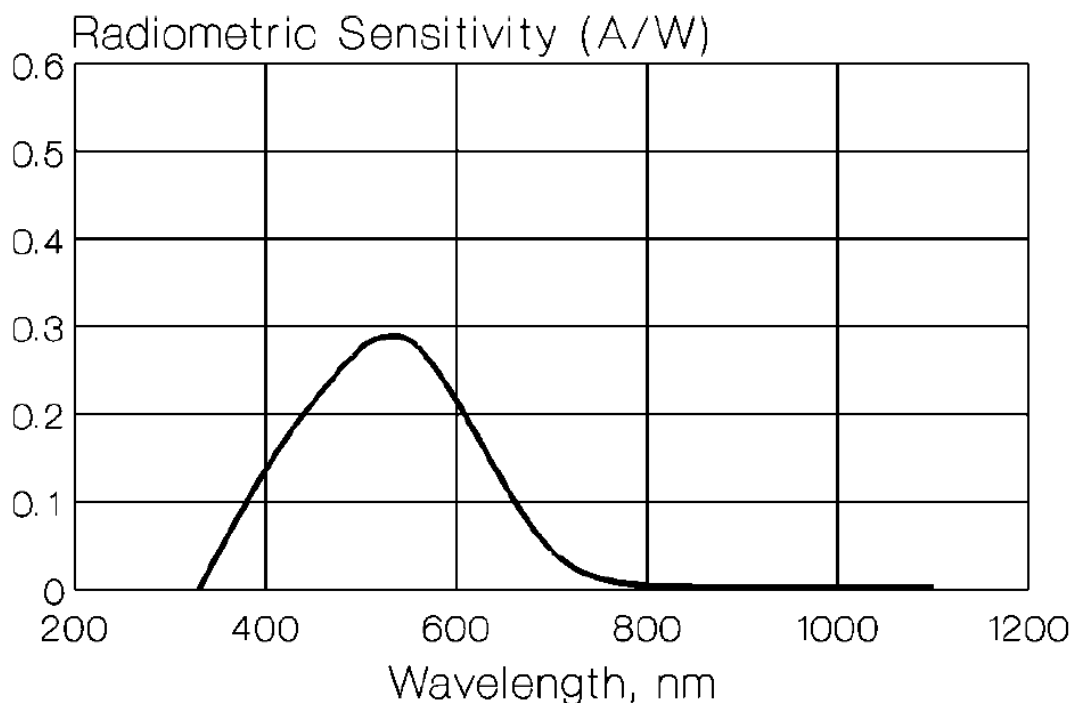

Figure 4. VTB8441BH Photodiode Responsivity Taken from Datasheet [22].

Requirement	Verification
<ol style="list-style-type: none"> 1. Outputs 1-2 μA of current when $150\mu\text{W}/\text{cm}^2$ of blue light is incident on the detector. 	<ol style="list-style-type: none"> 1. In a dark room, place the photodiode 50 cm in front of an EWS workstation screen. 2. Set the screen to full brightness on a white background. 3. Use an ammeter to verify that photocurrent output is between 1-2 μA.

2.3.2 Amplifier

Once a photocurrent is generated from the photodiode, the photocurrent must be amplified and converted into a usable voltage. This will be done using a LMP7717 operational amplifier in the transimpedance amplifier configuration. This amplifier was selected because of its ability to run off a single voltage supply and because of the wide range of supply voltages it can operate under (1.8-5.5 V) which is useful since our device will be battery supplied. It has a low quiescent current of 1.15 mA and its input bias current is on the order of a few pA which will allow us to achieve a high gain of the photocurrent. The gain of the amplifier is determined by the feedback resistor R1 shown in

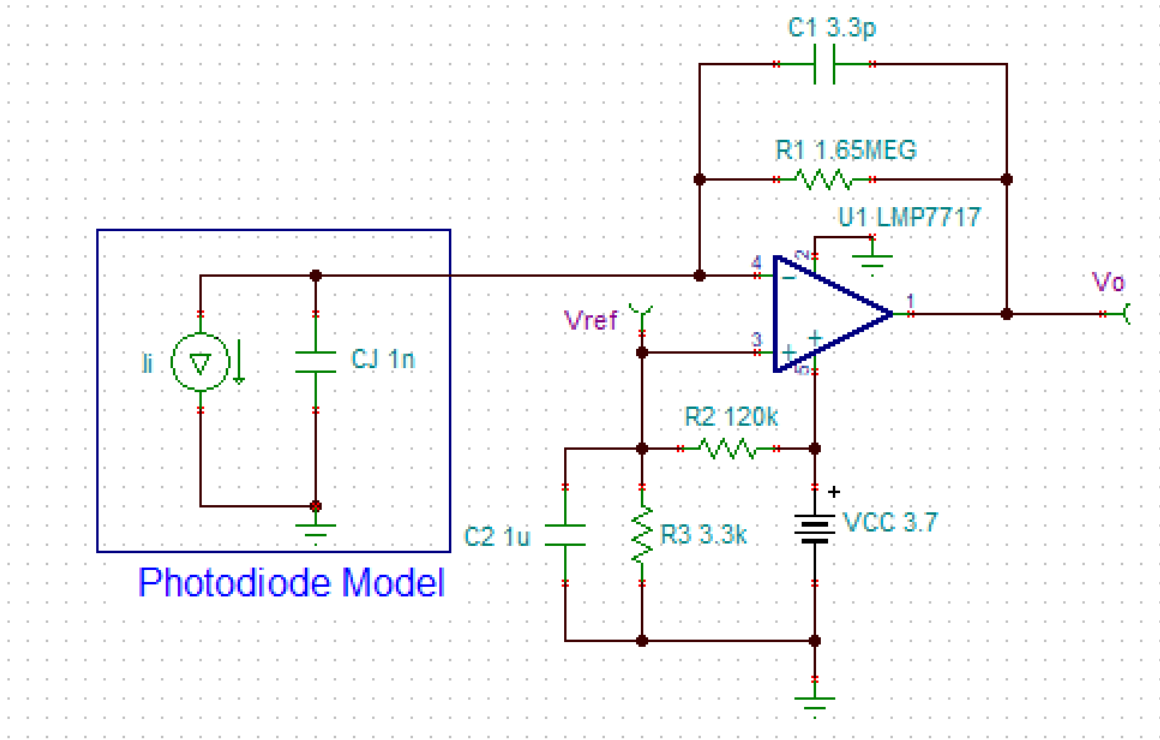

Figure 5. Amplifier Circuit

Figure 5. For correct operation the amplifier should output between 2.2-2.7 V when the photocurrent is 1.5 μA . This yields a feedback resistor value of 1.65 M Ω . The feedback capacitor needs to be less than $1/2\pi f_p R_1 = 4.8$ pF to ensure stability for a bandwidth of 20 kHz. A voltage divider is used to set the reference voltage to 0.1 V to prevent saturation when no photocurrent is present. The ratio of R_2/R_3 should be 36 to achieve this bias. The DC transfer characteristics of this circuit can be seen in Figure 6. The amplifier was based on a reference design from TI [23].

Requirement	Verification
<ol style="list-style-type: none"> Converts current to 0.1-V_{bias} V with magnitude of voltage depending linearly on input current at DC. At an input current of 1.5 μA and bias of 3.7 V outputs 2.2-2.7 V Operates on a bias voltage between 3.5-5.5 V 	<ol style="list-style-type: none"> Bias circuit as shown in Figure 5 schematic with V_{bias} between 3.5-5 V. <ol style="list-style-type: none"> Connect a current source to the non-inverting input of the amplifier. Sweep current values from 0-5 μA Verify that voltage output sweeps from 0.1-V_{bias} and saturates at V_{bias}.

	<ul style="list-style-type: none">2. Bias circuit as shown in Figure 5 schematic with $V_{bias} = 3.7\text{ V}$<ul style="list-style-type: none">a) Provide $1.5\ \mu\text{A}$ to the non-inverting input of the amplifierb) Verify output voltage is between $2.4\text{-}2.8\text{ V}$3. Bias circuit as shown in Figure 5 schematic with $V_{bias} = 3.5\text{ V}$<ul style="list-style-type: none">a. Provide $1.5\ \mu\text{A}$ to the non-inverting input of the amplifierb. Verify output voltage is between $2.2\text{-}2.7\text{ V}$c. Set bias to 5.5 Vd. Verify output voltage is between $2.2\text{-}2.7\text{ V}$
--	---

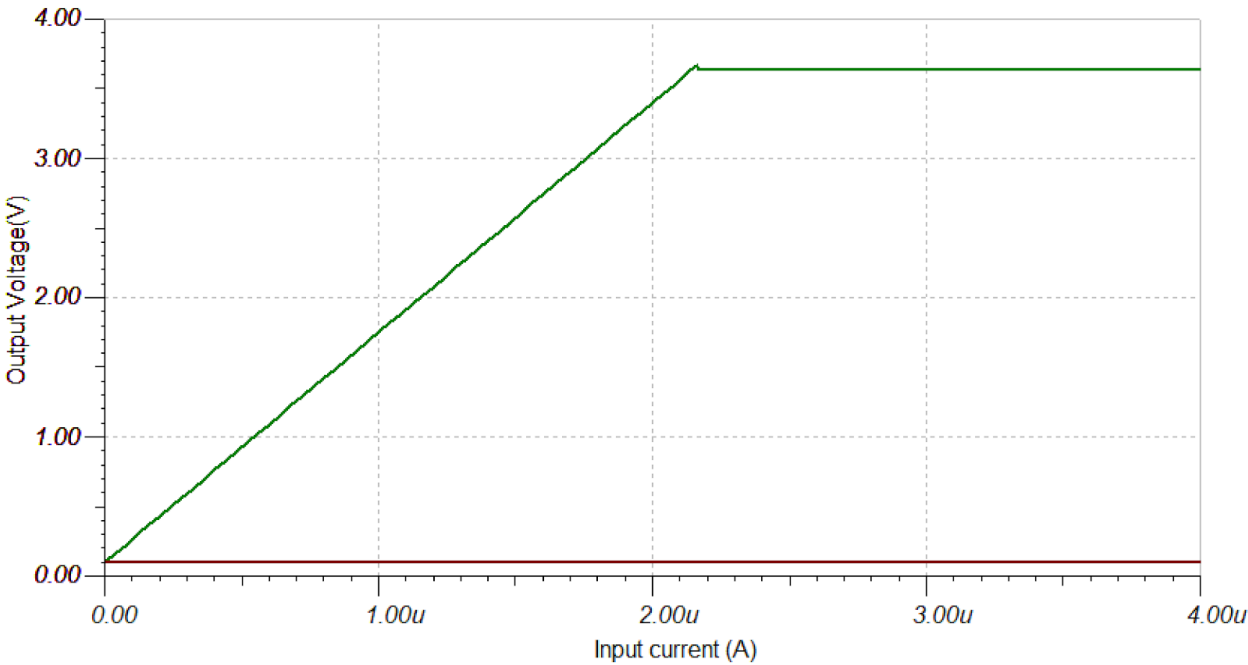

Figure 6. DC Transfer Characteristics of Amplifier

2.3.3 Analog to Digital Converter (ADC)

The ADC will read the output from the transimpedance amplifier and output a logical 1 or logical 0 based on whether the amplifier voltage is above or below the threshold. This will be done with a non-inverting Schmitt-Trigger buffer. When biased to 3.7 V the Schmitt-Trigger buffer will have a turn-on threshold between 1.8-2.2 V as seen in Figure 7.

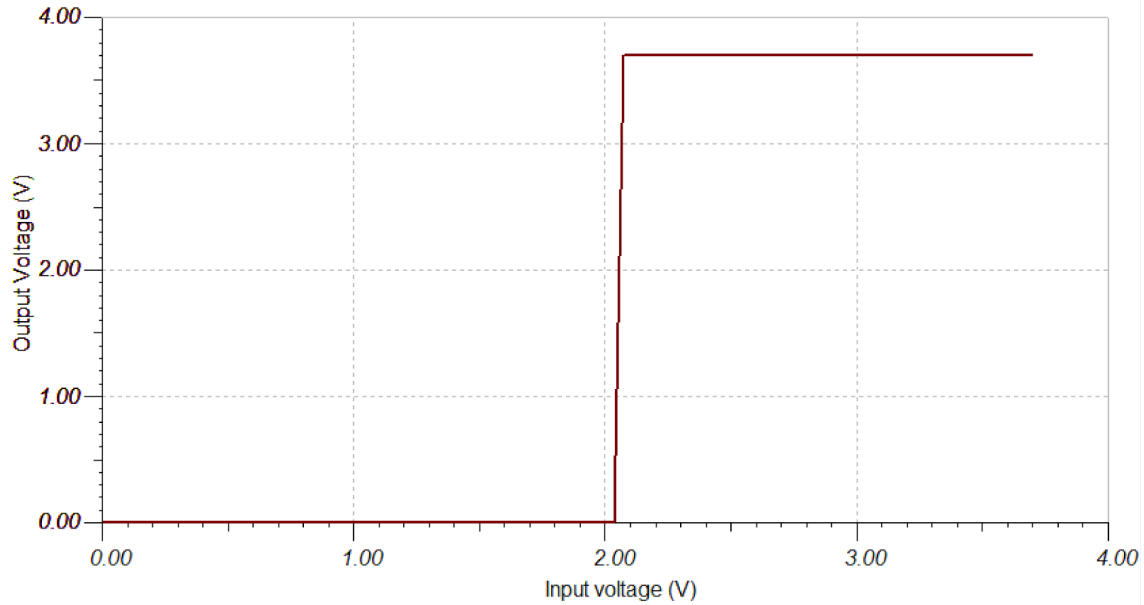

Figure 7. DC Transfer Characteristics of Non-inverting Schmitt Trigger Buffer.

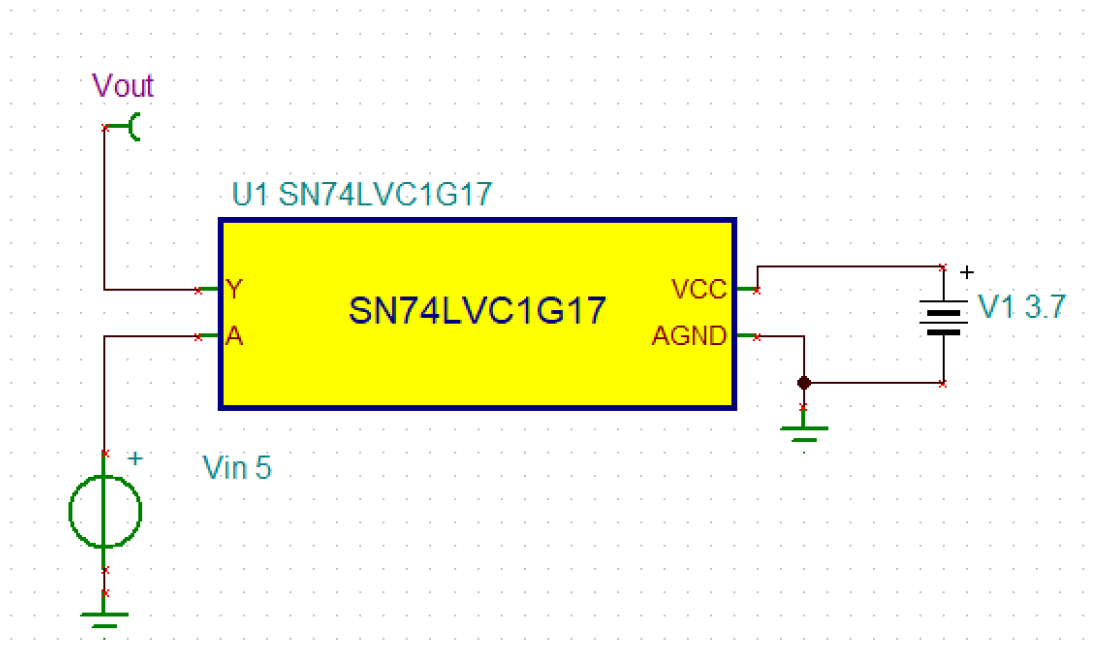

Figure 8. Non-Inverting Schmitt-Trigger Buffer Circuit.

Requirement	Verification
1. Outputs logical 1 (≥ 2.7 V) when amplifier voltage has a magnitude ≥ 2.2 V.	1. Bias Schmitt-Trigger to 3.7 V a. Use a power supply to sweep different voltages between 0-3.7 V and plot the voltage transfer characteristic. b. Verify that input voltages ≥ 2.2 V yield output voltages ≥ 2.7 V.

2.4 Timing Module

This module takes input from the Control Logic Module and User Interface Module to determine what the blue light exposure threshold time is and when the threshold has been passed. It consists of an oscillator and a counter. The 24th bit of the counter is inverted (\sim INDICATOR) and sent as an input into the Control Logic Module, along with the output of the oscillator (OSC_CLK).

2.4.1 Oscillator

The oscillator is a LM555CN chip that oscillates at a frequency determined by a variable resistor in an RC circuit. The RC circuit is defined on page 5 of the datasheet for the oscillator. The frequency of the oscillator depends on RA, RB, and C1 based on Equation 1. Because the values of these three components are all able to be changed, we will determine the actual values of RA, RB, and C1 to be used during the breadboarding process. At this point, it is sufficient to say that the values of RA, RB, and C1 will be chosen to match the necessary frequencies in Table 1. An example resistance range combination for 1 nF capacitance would be (RA+2RB) in the range of 154 k Ω to 1.3 M Ω in order to achieve time thresholds of 15 minutes to 2 hours. The resistance of the variable resistor can be changed by the user when they turn the knob of the variable resistor. The oscillator frequencies required to meet the tolerance range of exposure time thresholds specified in the requirements below are shown in Table 1. The output of the oscillator (OSC_CLK) is sent to the Control Logic module and where it is an input to the effective 3-input AND gate.

Requirement	Verification
1. Oscillator is able to oscillate at frequencies between 1kHz and 10 kHz. 2. Must be able to output frequencies required for measuring all user-inputted exposure time thresholds between 15 minutes and 2 hours (with 15 minute	1. Use test circuit and oscilloscope to verify that these frequencies are possible. a) Set up oscillator chip and appropriate inputs to make the oscillator oscillate at frequencies

<p>increments in that range) with an accuracy of ± 5 minutes (between each set of lower bound and upper bound frequencies) as described in Table 1.</p>	<p>between 1 kHz and 10 kHz. Use a variable resistor and or a variable capacitor to change the threshold-input (pin 6) voltage and set the oscillator frequency according to Equation (1).</p> <p>b) Connect an oscilloscope coaxial cable with the BNC end connected to input channel 1 of the oscilloscope and with the two banana plugs (red and black) connected to two wires that separately probe ground and the oscillator output.</p> <p>c) Adjust the oscilloscope time scale and voltage range to the appropriate time scale given the period of the desired range of frequencies. Record the values of the frequencies measured and compare them to the theoretical frequency range.</p> <p>2. Use a timer and oscilloscope to verify that oscillation periods properly correspond to the frequency set within the tolerance stated.</p> <p>a) Set up oscillator chip and appropriate inputs to make the oscillator oscillate at the frequencies required for time measurements of between 15 minutes to 2 hours (with 15 minute increments). Use a variable resistor and or a variable capacitor to change the threshold-input (pin 6) voltage and set the oscillator frequency according to Equation 1.</p> <p>b) Connect an oscilloscope coaxial cable with the BNC end</p>
--	---

	<p>connected to input channel 1 of the oscilloscope and with the two banana plugs (red and black) connected to two wires that separately probe ground and the oscillator output.</p> <p>c) Adjust the oscilloscope time scale and voltage range to the appropriate time scale given the period of the desired frequency. Record the values of the frequencies measured and compare them to the desired frequency range for each time threshold.</p>
--	---

$$f=1.44/[(Ra+2Rb)*C1] \text{ (Equation 1)}$$

Table 1. Oscillator Frequencies Required for Time Measurements in 15 Minute Intervals with ± 5 Minute Accuracy

Desired Time Threshold [minutes]	Lower Bound Time Threshold [minutes]	Upper Bound Time Threshold [minutes]	Required Oscillator Frequency [Hz]	Lower Bound Frequency [Hz]	Upper Bound Frequency [Hz]
15	10	20	9320.675556	6990.506667	13981.01333
30	25	35	4660.337778	3994.575238	5592.405333
45	40	50	3106.891852	2796.202667	3495.253333
60	55	65	2330.168889	2150.925128	2542.002424
75	70	80	1864.135111	1747.626667	1997.287619
90	85	95	1553.445926	1471.685614	1644.825098
105	100	110	1331.525079	1271.001212	1398.101333
120	115	125	1165.084444	1118.481067	1215.74029

2.4.2 Counter

The counter is a CD4521BM96 chip that will help to determine when the time threshold has passed. The frequency at which it counts depends on the frequency of the oscillator. Regardless of oscillation frequency, the counter counts up until the 24th bit is a 1. Once that number is reached, the 24th bit of the counter (INDICATOR signal) is sent to the Control Logic Module, where it is inverted (\sim INDICATOR) and sent to the Indicator Subsystem in the User Interface Module to turn the LED on and notify the user that the blue light exposure time threshold has passed. The \sim INDICATOR signal also goes into the effective AND gate with the BLUE_EXPOSURE signal and the OSC_CLK signal to pause the counter when the time threshold has been reached.

Requirement	Verification
<ol style="list-style-type: none"> 1. Needs to be able to operate on 3.5-3.8 V. 2. Should be able to operate at frequencies in the range of 1 kHz to 10 kHz. 	<ol style="list-style-type: none"> 1. Provide supply voltage of 3.5 V to counter. <ol style="list-style-type: none"> a. Use a function generator to provide a square wave to the clock of the counter. b. Use a voltmeter to verify counting operation. c. Repeat with supply voltage of 3.8 V 2. Use a function generator to provide square waves of 1 kHz and 10 kHz to the clock input of the counter. <ol style="list-style-type: none"> a. For each frequency, reset the counter manually. b. Then use a voltmeter to probe the 14th bit of the counter and ensure that it is set low. c. Then after allowing the counter to count, for the 1 kHz frequency, wait approximately 16 seconds and see if the 14th bit of the counter has been set to 1; on the other hand, for the 10 kHz frequency, wait approximately 1.6 seconds and see if the 14th bit of the counter is set to 1 at this time.

	<p>d. If the counter bit is set correctly in step 2.c), then the counter is able to operate at the desired frequency range.</p>
--	---

2.5 Power Module

The power module delivers power to the components of the circuit as needed. It consists of the TinyCircuits ASR00011 battery pack that will supply 3.7 V for use in all necessary circuits as shown in Figure 2 and a voltage regulator TLV70237 from Texas Instruments that will allow the battery to deliver continuous 3.7 V. The charger is an off-the-shelf charger that charges the battery pack through the charging port shown in Figure 3.

2.5.1 Battery

The battery is a TinyCircuits ASR00011 lithium-ion battery that is the power source for the system. The battery power will either be supplied or not supplied based on the mechanical on/off switch that is part of the User Interface Module. In the case that the switch is off, an open circuit will be created so that the battery does not supply any current to the rest of the circuit.

Requirement	Verification
1. Provides between 3.5 - 4.2 V.	<ol style="list-style-type: none"> 1. Use a voltmeter to measure the voltage of the battery bank. 2. Verify that the voltage falls within the tolerance range.

2.5.2 Voltage Regulator

The voltage regulator will be the TLV70237 linear low-drop out (LDO) voltage regulator. A linear regulator was chosen in order to achieve a low noise output voltage for the amplifier circuit. This low-drop out voltage was chosen in order to output a voltage close to the input voltage. The voltage regulator takes input from the battery and outputs continuous 3.7 V for the oscillator and counter in the Timing Module, the logic gates in the Control Logic Module, and the LED in the Indicator Subsystem in the User Interface Module.

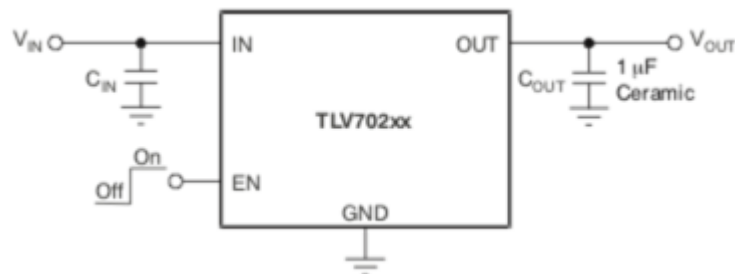

Figure 9: Sample circuit using the TLV70237 voltage regulator

Requirement	Verification
<ol style="list-style-type: none"> 1. Provides continuous 3.7 V \pm5% at 30mA current draw. 2. Has voltage drop, voltage difference between the input and output voltages, of less than 500 mV. 3. Has an efficiency of over 75%. 	<ol style="list-style-type: none"> 1. <ol style="list-style-type: none"> a. Connect charged battery to input of regulator with a 1 μF capacitor shunted to ground from the Vin and Vout pins. b. Attach a 120 Ω resistor as a load. c. Use a multimeter to probe the output voltage of the voltage regulator. d. Use an ammeter to measure the current across the resistor. e. Verify values fall within tolerance ranges. 2. <ol style="list-style-type: none"> a. Set up voltage regulator circuit as shown in Figure 9. b. Attach a power supply set to 4.2 V to the input of the voltage regulator. c. Measure the voltage at the output of the voltage regulator using a multimeter. d. Calculate the voltage drop and verify that it falls below 500 mV. 3. <ol style="list-style-type: none"> a. Set up voltage regulator circuit as shown in Figure 9. b. Attach power supply set to 4.2 V to the input of the voltage regulator. c. Use an ammeter to measure the current across the input. d. Calculate the power from the input using the measured current and input voltage. e. Use an ammeter to measure the current across the output.

	<ul style="list-style-type: none"> f. Use a voltmeter to measure the output voltage. g. Calculate the power from the output from the using the measured current and output voltage. h. Calculate the efficiency and verify that it is above 75%.
--	---

2.6 User Interface Module

This module allows the user to adjust the exposure time threshold and to be notified when that time threshold has been passed. It consists of the Indicator Subsystem and User Input. The User Input subsystem consists of a knob, an on/off switch, and a reset button on the lateral side of the external housing. The knob will control a variable resistor in order to change the frequency of the oscillator. There are markings along the outer circumference of the knob that correspond to time thresholds of 15 minutes to 2 hours with 15 minute intervals.

2.6.1 Indicator Subsystem

This circuit consists of the LED that notifies the user that the exposure time threshold has been reached. When the time threshold is reached, the \sim INDICATOR signal will be logical 0 and the LED will turn on and stay on until the reset button is pressed, at which point the LED will turn off. The Indicator Subsystem circuit will have a current limiting resistor in series with the LED, and the LED's positive terminal will be connected to the battery voltage through the current limiting resistor, while the negative terminal will be fed the \sim INDICATOR signal through the output of an inverter, as shown in Figure 10.

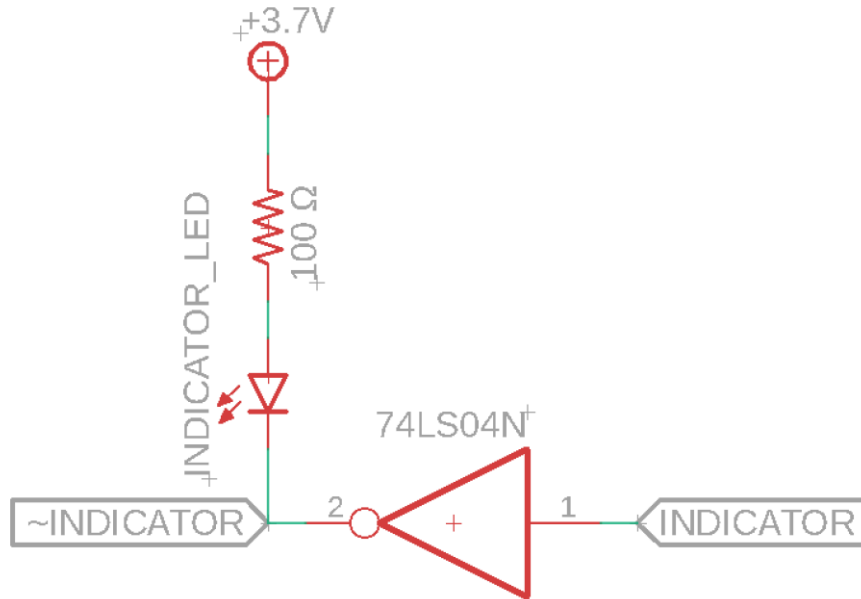

Figure 10. Indicator Subsystem LED Driver Circuit.

Requirement	Verification
1. Visible from peripheral vision <1ft from face.	1. Power LED with current limiting resistor as shown in schematic <ol style="list-style-type: none"> a. Place LED in peripheral view at a distance <1ft and verify visibility.

2.6.2 User Input

The user input consists of the on/off switch, reset button, and knob. The knob will be connected to a variable resistor, which will be part of an RC circuit that controls the oscillation frequency of the oscillator. The on/off switch controls whether power is supplied from the battery pack. The reset button connects to the counter in the Timing Module.

Requirement	Verification
1. Variable resistor adjustment knob should be tunable using ones hands only, and it should cover all possible resistance values within 0 to 360 degrees rotation.	1. Connect resistor to ohmmeter <ol style="list-style-type: none"> a) Turn knob with hands only to verify that it is easily turned. b) Verify low end resistance at zero degrees rotation. c) Verify high end resistance occurs at <360 degrees.

2.7 Control Logic Module

This module consists of an AND gate and one inverter. The inputs to the AND gate are the BLUE_EXPOSURE signal, the OSC_CLK signal, and the INDICATOR signal. The BLUE_EXPOSURE signal comes from the Sensor Module and indicates when blue light past the intensity threshold is incident on the photodiode and thus on the user's eyes as well. The OSC_CLK signal is simply the output of the oscillator. The INDICATOR signal is the 24th bit of the counter. The output CLK signal goes to the clock input of the counter in the Timing Module. The \sim INDICATOR signal (the inverted INDICATOR signal) goes to the Indicator Subsystem.

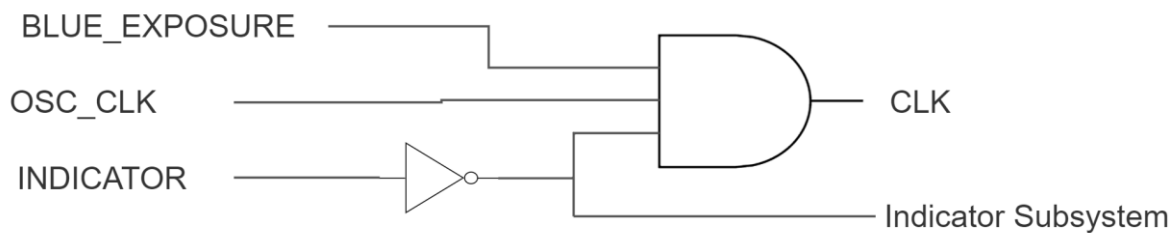

Figure 11. Control Logic Diagram

Table 2. Control Logic Truth Table

BLUE_EXPOSURE	OSC_CLK	INDICATOR	CLK
0	0	0	0
0	0	1	0
0	1	0	0
0	1	1	0
1	0	0	0
1	0	1	0
1	1	0	1
1	1	1	0

Requirement	Verification
1. Verify that logic circuit corresponds to truth table in Table 2.	1. Construct logic circuit shown in Figure 11 and bias to 3.7 V. <ol style="list-style-type: none"> a. Using a power supply to setup a 3.7 V and GND rail. b. Set inputs to appropriate values (shown in Table 2) using power rails.

	<ul style="list-style-type: none"> c. Use a voltmeter to read at CLK output. d. Verify that inputs and output match truth table.
--	--

2.8 Tolerance Analysis

A critical component for the successful operation of this device is the sensor module. This module provides the only method for the device to detect blue light from the outside world. It was determined that $150 \mu W/cm^2$ of blue light incident on one's eyes is enough to start causing problems. For tolerance analysis we will look at the worst case scenario for blue light detection by the sensor module. The basic signal flow through the sensor module is that light which passes through a dichroic filter is incident on a photodiode which generates a current, this current is fed into a transimpedance amplifier which outputs a voltage range and this voltage is fed into a Schmitt Trigger which will output either a logical one or zero depending on if a voltage threshold is passed.

The dichroic filter will filter out other colors that we are not interested in. In doing so an average of 85% [24] of the blue light will be transmitted. For $150 \mu W/cm^2$ this will yield

$$150 \cdot .85 = 127.5 \mu W/cm^2$$

of light incident on the photodiode.

The tolerances for the photodiode we are using are not clearly defined. For our purposes we will assume an average responsivity of 0.2 A/W with a tolerance of 10%. This yields a worst case responsivity of 0.18 A/W. The active area of this photodiode is $5.16 mm^2$ so a total power of

$$127.5 \cdot 0.0516 = 6.579 \mu W$$

Will be incident on the photodiode resulting in a photocurrent of

$$6.579 \cdot 10^{-6} \cdot .18 = 1.184 \mu A$$

This current is fed into the non-inverting input of a transimpedance amplifier so a usable voltage can be generated. In its most basic operation the output of the transimpedance amplifier is determined by the equation

$$V_{out} = -I_{in}R_f$$

where R_f is the feedback network resistance. For our purposes a feedback resistance of $1.65 M\Omega$ with a tolerance of $\pm 1\%$. A smaller resistance will result in a lower gain so a resistance of $1.63 M\Omega$ will be used to calculate the output voltage. A simulation with the worst-case-scenario feedback network is shown in Figure 12. Which results in an output voltage of 2.02 V.

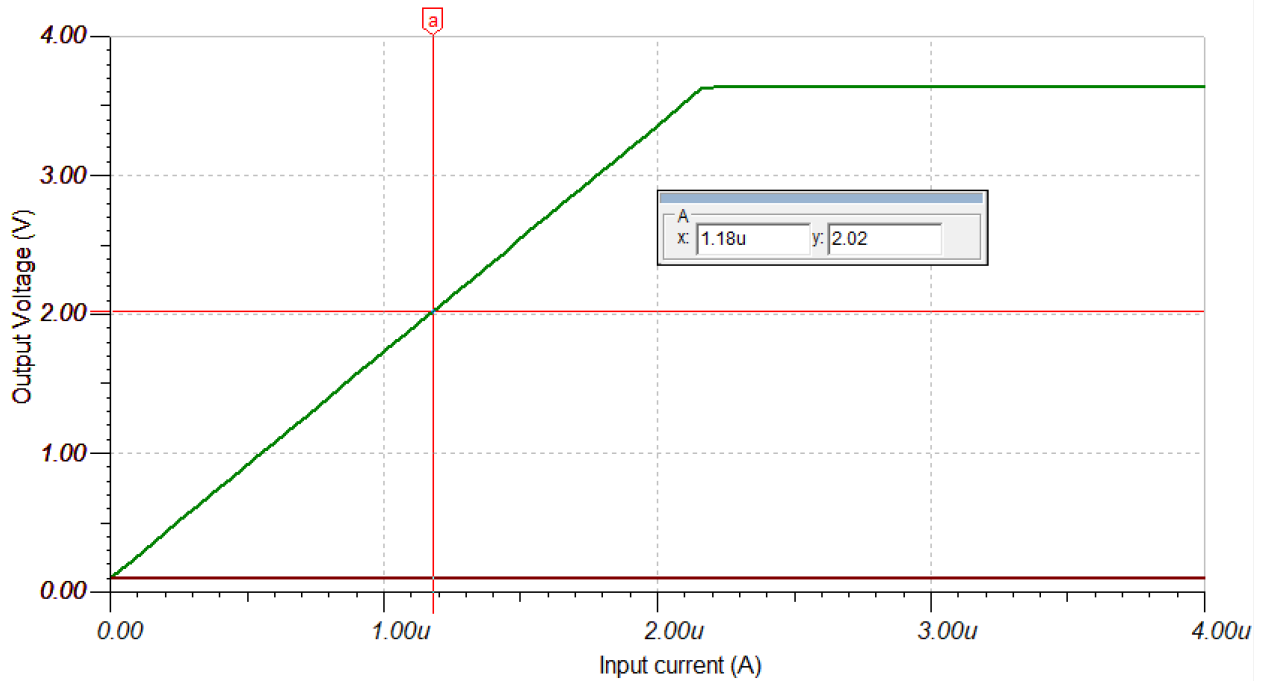

Figure 12. Amplifier Worst Case Feedback Network

This output voltage is fed into the input of a Non-inverting Schmitt-Trigger buffer to output a digital logic signal. Based on the datasheet for the Schmitt-Trigger the turn on voltage at a bias of 3.7 V was estimated to be between 1.8-2.3 V so the output voltage from the amplifier falls into the turn on range of the Schmitt-Trigger in the worst case scenario.

3. Costs

The labor cost per hour is estimated to be \$50 per person at 10 hours per week over a 9 week period. The total cost is calculated as follows:

$$\$50/[\text{hr} \times \text{person}] * 10 [\text{hr}/\text{wk}] * 9 [\text{wk}] * 3 [\text{people}] * 2.5 = \$33,750$$

Table 3. Components List

Type	Manufacturer	Part #	Quantity	Unit Cost	Total Cost
Photodiode	Excelitas Technologies	VTB8441BH	1	\$7.29	\$7.29
ADC	Texas Instruments	SN74LVC1G17DBVR	1	\$0.32	\$0.32
Oscillator/ Timer	Texas Instruments	TLC555CP	1	\$0.84	\$0.84
Amplifier	Texas Instruments	LMP7717MF/NOPB	1	\$2.01	\$2.01
Dichroic filter	Edmond Optics	52-530	1	\$19.50	\$19.50
Charger	TinyCircuits	ASL2112	1	\$6.95	\$6.95
Battery	TinyCircuits	ASR00011	1	\$3.49	\$3.49
Inverter	Texas Instruments	SN74LVC2GU04DBVR	1	\$0.40	\$0.40
Counter	Texas Instruments	CD4521BM96	1	\$0.48	\$0.48
3-Input AND	Texas Instruments	SN74LVC1G11DCKR	1	\$0.44	\$0.44
LED	Everlight Electronics Co Ltd	HLMP1340	1	\$0.87	\$0.87
Voltage regulator	Texas Instruments	TLV70237DBVR	1	\$0.50	\$0.50
				Total	\$43.09

Total cost = Labor + Parts = \$33,750 + \$43.09 = \$33,793.09

4. Schedule

Table 4. Schedule

Week	David	Erik	Jane
Week 1: 2/24/2020	Work on the design document. Determine what components are needed for the logical circuit. Begin designing the circuit for the Indicator Subsystem.	Work on the design document. Begin working on the oscillator and amplifier circuits. Determine appropriate ICs for the control logic module given power constraints.	Work on the design document. Determine appropriate battery given size and power constraints.
Week 2: 3/2/2020	Order parts for the breadboarded prototype circuit. Begin preliminary circuit assembly. Finish designing the circuits for the Control Logic module and User Interface module.	Finish working on the circuit designs for the timing module and sensor module. Begin preliminary circuit assembly.	Finish working on the circuits for the battery. Start making a prototype for the power module. Begin unit testing the power module according to requirements.
Week 3: 3/9/2020	Unit test the Control Logic and User Interface modules. Complete verifications for the oscillator and counter chips. Begin assembling Timing Module and completing replicate time trials.	Calculate resistances required to adjust oscillator frequency. Adjust the oscillator circuit accordingly as needed. Unit test the sensor and timing modules. Test all circuits together to ensure functionality.	Unit test the power module. Test all circuits together to ensure functionality. Test the photodiode module to verify that photodiode output meets requirements.
Week 4: 3/23/2020	Work on User Interface and Timing Module portions of the PCB. Verify all components are present and circuit implementation is correct. Introduce test points to PCB design.	Work on sensor and timer module portions of the PCB. Verify that PCB circuits are correct and that tolerances and requirements are all satisfied.	Work on the battery module portion of the PCB. Combine circuits into one PCB. Discuss PCB order with TA. Begin the auditing process for the PCB.

			Order the PCB if the audit is passed.
Week 5: 3/30/2020	Continue to verify functionality of the circuit on the PCB.	Test sensor and timing module portions of the PCB to see if they meet requirements.	Test actual components. Determine if the battery module portion of PCB is operational by performing testing.
Week 6: 4/6/2020	Solder components onto PCB, begin designing mechanical housing.	Create a 3D model of the housing. Solder components onto PCB.	Solder components onto PCB.
Week 7: 4/13/2020	Combine PCB with mechanical housing to achieve a fully functional device.	Create physical housing.	Perform testing on housing to determine if it satisfies the requirements noted in safety and ethics.
Week 8: 4/20/2020	Practice presentation and prepare for demonstration.	Prepare for demonstration and presentation.	Prepare for demonstration and presentation.
Week 9: 4/27/2020	Final Demo	Final demo	Final demo

5. Ethics and Safety

There are three major concerns that will need to be handled carefully during the development of the device. The first concern is regarding charging lithium-ion batteries. Our device is powered using lithium-ion batteries which will be charged. When charging lithium-ion batteries there is a chance for chemical reactions to occur due to physical damage or electrical damage, which could be introduced due to overcharging [27]. The consequences of such a reaction occurring can range from smoke to large explosions. It is necessary according to IEEE code of ethics, #1: “to hold paramount the safety, health, and welfare of the public, to strive to comply with ethical design and sustainable development practices, and to disclose promptly factors that might endanger the public or the environment” [28]. In order to uphold this practice it is necessary to make certain that the process of charging and discharging the batteries is safe for the regular consumer. To ensure this we will make certain that the batteries involved will never be overcharged (above 4.2 V) or over-discharged (below 3 V) by using the Powerboost 500 charger from Adafruit, that has already been tested and RoHS-certified. In addition, the battery will undergo testing using an oscilloscope to measure output voltage prior to being connected to the device. [26]

The second concern is regarding water damage. As this device can be used in place of a pair of regular glasses, there is a possibility the device may be submerged the user washes the glasses. As such there is a chance that the user could be shocked. It is necessary according to the IEEE code of ethics, #9: “to avoid injuring others, their property, reputation, or employment by false or malicious action” [29]. Hence it is necessary that the device is safe to use even in the presence of water and will not harm someone. To do this, all electrical components will be secured using a case with a thickness sufficient to keep water out.

The third concern is regarding the dangers of electromagnetic radiation. The type of electromagnetic radiation that is of greatest concern with regards to our project is radio frequency. Electronic devices such as radios, Wi-Fi and Bluetooth devices, and radars can produce radio frequency. Radio frequency can cause damage to the human body if absorbed in large amounts [29]. According to the FCC’s policy on radio frequency safety, “the NCRP’s recommended Maximum Permissible exposure limits field strength and power density for the transmitters operating at frequencies of 300 kHz to 100 GHz” [30]. Our project is unlikely to operate at such frequencies so the danger of electromagnetic radiation will be limited.

In the case that any additional concerns that we are unable to handle appear during the development process in order to adhere to IEEE code of ethics #6: “to maintain and improve our technical competence and to undertake technological tasks for others only if qualified by training or experience, or after full disclosure of pertinent limitations”, we will discuss how to overcome the challenges concerned or seek someone with greater knowledge with regards to the challenge [28]. We will disclose any additional safety concerns as they appear.

References

- [1] Tähkämo, Leena, Partonen, Timo & Anu-Katriina Pesonen. “Systematic review of light exposure impact on human circadian rhythm.” *Chronobiology International* 36:2 (2019): 151-170, doi: 10.1080/07420528.2018.1527773
- [2] Brainard, G C et al. “Action spectrum for melatonin regulation in humans: evidence for a novel circadian photoreceptor.” *The Journal of Neuroscience: the Official Journal of the Society for Neuroscience* 21,16 (2001): 6405-12. doi:10.1523/JNEUROSCI.21-16-06405.2001
- [3] Thapan, K et al. “An action spectrum for melatonin suppression: evidence for a novel non-rod, non-cone photoreceptor system in humans.” *The Journal of Physiology* 535 (2001): 261-7. doi:10.1111/j.1469-7793.2001.t01-1-00261.x
- [4] Touitou, Yvan, Reinberg, Alain, and David Touitou. “Association between light at night, melatonin secretion, sleep deprivation, and the internal clock: Health impacts and mechanisms of circadian disruption.” *Elsevier* 173 (2017): 94-106. doi:10.1016/j.lfs.2017.02.008
- [5] Zhao, Zhi-Chun et al. “Research progress about the effect and prevention of blue light on eyes.” *International Journal of Ophthalmology* 11,12 (1999-2003). doi:10.18240/ijo.2018.12.20
- [6] “Visible Spectrum.” *Wikipedia*, 7 Feb. 2020. https://en.wikipedia.org/wiki/Visible_spectrum. 11 Feb. 2020.
- [7] Heiting, Gary. “Blue light: It's both bad and good for you.” *All About Vision*, Nov. 2017. <https://www.allaboutvision.com/cvs/blue-light.htm>. 11 Feb. 2020.
- [8] Bonmati-Carrion, Maria Angeles et al. “Protecting the melatonin rhythm through circadian healthy light exposure.” *International journal of molecular sciences* 15, 12 (2014): 23448-500. doi:10.3390/ijms151223448
- [9] “Blue light has a dark side.” *Harvard Health Publishing*, Cambridge, MA, 13 August, 2018. <https://www.health.harvard.edu/staying-healthy/blue-light-has-a-dark-side>. 11 Feb. 2020.
- [10] “BLUE LIGHT Computer Glasses.” *Quay Australia*, 2020. <https://www.quayaustralia.com/collections/blue-light-computer-glasses>. 11 Feb. 2020.
- [11] “Protect Your Eyes From Blue Light.” *Zenni Optical*, 2020. <https://www.zennioptical.com/blokz-blue-light-glasses>. 11 Feb. 2020.
- [12] Mark Coppock. “How to use a blue light filter on your PC or Mac.” *Digital Trends*, 12 Nov. 2019. <https://www.digitaltrends.com/computing/how-to-use-a-blue-light-filter-on-pc-mac/>. 13 Feb. 2020.
- [13] Pierce, Brooke and Denise True. “Protect your eyes from harmful light.” *Mayo Clinic Health System*, 19 May, 2017. <https://www.mayoclinichealthsystem.org/hometown-health/speaking-of-health/protect-your-eyes-from-harmful-light>. 13 Feb. 2020.
- [14] Palavets, Tatsiana, and Mark Rosenfield. “Blue-blocking Filters and Digital Eyestrain.” *Optometry and Vision Science* 96.1 (2019): 48-54. doi:10.1097/OPX.0000000000001318

- [15] Vimont, Celia. "Should You Be Worried About Blue Light?" *American Academy of Ophthalmology*, Ed. Kurana, Rahul, 24 Aug. 2017. <https://www.aaopt.org/eye-health/tips-prevention/should-you-be-worried-about-blue-light>. 13 Feb. 2020.
- [16] Landers, John A., Tamblyn, David and Don Perriam. "Effect of a blue-light-blocking intraocular lens on the quality of sleep." *Journal of Cataract and Refractive Surgery* 35.1 (2009): 83-88. doi:10.1016/j.jcrs.2008.10.015
- [17] Leung, Tsz Wing et al. "Blue-Light Filtering Spectacle Lenses: Optical and Clinical Performances." *PloS one* 12.1 (2017). doi:10.1371/journal.pone.0169114
- [18] Ostrin, Lisa A., Abbott, Kaleb S. and Hope M. Queener. "Attenuation of short wavelengths alters sleep and the ipRGC pupil response." *Ophthalmic & Physiological Optics* 37 (2017): 440–450. doi:10.1111/opo.12385
- [19] Blume, Christine et al. "Effects of light on human circadian rhythms, sleep and mood." *Somnologie : Schlafforschung und Schlafmedizin = Somnology : sleep research and sleep medicine* 23.3 (2019): 147-156. doi:10.1007/s11818-019-00215-x
- [20] Kazemi, Reza et al. "The effects of screen light filtering software on cognitive performance and sleep among night workers." *Health promotion perspectives* 9.3 (2019): 233-240. doi:10.15171/hpp.2019.32
- [21] Lee, Yong J. User-wearable devices that monitor exposure to blue light and recommend adjustments thereto. US9655525 B2. United States Patent and Trademark Office, 23 May, 2017. *Google Patents*. <https://patents.google.com/patent/US9655525B2/en>
- [22] Excelitas Technologies. "VTB Process Photodiodes - VTB8440B, 8441B." n.d. Web. 22 February 2020.
- [23] Texas Instruments. "1 MHz, Single-Supply, Photodiode Amplifier Reference." 2014. Web. 22 February 2020.
- [24] Edmund Optics Inc. *12.5mm Square, Blue Dichroic Filter*. 2020. Web. 27 February 2020.
- [25] Texas Instruments. SN74LVC1G17 Single Schmitt-Trigger Buffer. April 2014. Web. 27 February 2020.
- [26] "Lithium Ion Polymer Battery 70mAh - ASR00011." Tiny Circuits. http://files.tinycircuits.com/Datasheets/TinyCircuits_ASR00011.pdf. 24 Feb 2020.
- [27] "LITHIUM BATTERY SAFETY." University of Washington, Apr. 2018. <https://www.ehs.washington.edu/system/files/resources/lithium-battery-safety.pdf>. 9 Feb. 2020.
- [28] "IEEE Code of Ethics." IEEE, 2020. <https://www.ieee.org/about/corporate/governance/p7-8.html>. 9 Feb. 2020.
- [29] "Microwaves, Radio Waves, and Other Types of Radiofrequency Radiation." American Cancer Society, 5 Jan. 2016. <https://www.cancer.org/cancer/cancer-causes/radiation-exposure/radiofrequency-radiation.html>. 9 Feb. 2020.

- [30] "FCC Policy on Human Exposure to Radiofrequency Electromagnetic Fields." Federal Communications Commission, 24 Nov. 2015. <https://www.fcc.gov/general/fcc-policy-human-exposure>. 13 Feb. 2020
- [31] "VTB Process Photodiodes VTB8440BH, 8441BH." Digikey. https://media.digikey.com/pdf/Data%20Sheets/Excelitas%20PDFs/VTB8440BH_8441BH.pdf. 27 Feb. 2020.
- [32] "SN74LVC1G17 Single Schmitt-Trigger Buffer." Texas Instruments, Apr. 2014. <http://www.ti.com/lit/ds/symlink/sn74lvc1g17.pdf>. 27 Feb. 2020.
- [33] "12.5mm Square, Blue Dichroic Filter." Edmond Optics, 2020. <https://www.edmundoptics.com/p/125mm-square-blue-dichroic-filter/40585/>. 27 Feb. 2020
- [34] "TINY BATTERY CHARGER." Digikey. https://media.digikey.com/pdf/Data%20Sheets/TinyCircuits%20PDFs/ASL2112_Web.pdf. 27 Feb. 2020.
- [35] "Lithium Ion Polymer Battery 70mAh - ASR00011." TinyCircuits. http://files.tinycircuits.com/Datasheets/TinyCircuits_ASR00011.pdf. 27 Feb. 2020.
- [36] "Dual Inverter Gate." Texas Instruments, Dec. 2013. <http://www.ti.com/lit/ds/symlink/sn74lvc2gu04.pdf>. 27 Feb. 2020.
- [37] "CD4521B Types." Texas Instruments, Oct. 2003. <http://www.ti.com/lit/ds/symlink/cd4521b.pdf>. 27 Feb. 2020.
- [38] "SN74LVC1G11 Single 3-Input Positive-AND Gate." Texas Instruments, Nov. 2016. <http://www.ti.com/lit/ds/symlink/sn74lvc1g11.pdf>. 27 Feb. 2020.
- [39] "Clear Lens T-100 Solid State Lamps." Digikey, 2006. <https://media.digikey.com/PDF/Data%20Sheets/Everlight%20PDFs/ds300035.pdf>. 27 Feb. 2020.
- [40] "TLV702 300-mA, Low-IQ, Low-Dropout Regulator." Texas Instruments, Jul. 2019. <http://www.ti.com/lit/ds/symlink/tlv702.pdf>. 2 Mar. 2020.