

ECE 445

Spring 2020

Group Project Design Document

Submetering the ECEB

Xiaolin Wu (xw5), Xiaoyi Shen (xiaoyis2), Tingyu Wang (tingyuw2)

Team Number: #2

TA: Evan Widloski

Prof: Jonathan Schuh

● Introduction

○ Problem and Solution Overview

○

Although our ECE building has the measurement of the total power generated by the solar panels on the roof and has its measure of total power consumption, it still lacks the ability to track the power consumed by each and every classroom, lab, and office. So our **problem** to solve in this project is to design a system that is able to measure the power used in individual rooms in ECEB. Therefore, aiming at the need to solve the issue for detection and display of the power consumed, our project can measure the power used in various labs and classrooms as well as offices in ECEB and have those data displayed in real time on a screen set on the first floor of the building. To accomplish this, our **solution** includes several local sensing systems that are placed in different rooms as well as a host that communicates with all the devices through Wi-Fi and have it displayed on the desired screen.

From the aspects of customer benefits, our project could help our administrators gain a better understanding about the distribution of the power consumption in this building and thus benefit any of their further decisions for the building. **Currently**, there are devices that can measure the AC power consumption using Arduino which is a little bit more expensive than our choices: the communication system is built based on ESP32s and only one Raspberry Pi Zero as the host and thus the cost of the whole project will be limited to a satisfactory state. Besides, if an Arduino is involved in the design, we would also acquire an external data transfer module which will make the project bigger and cost even more to build. In addition, due to its capability to measure both 3-phase and single phase electric circuits, it is thoroughly very marketable.

○ Visual Aid

○ High-Level Requirement List

- Functions to measure both 3-phase and single phase power with high voltage (~208V) and high current (200A ~ 400A) with 1% accuracy.
- Ability to offload data for displaying and refresh at least 4 times per hour.
- Have strong robustness to power failure with the setup of back power subsystem and a certain amount of local memories to store the local measuring data.

● Design

○ Block Diagram

<block diagram in modification>

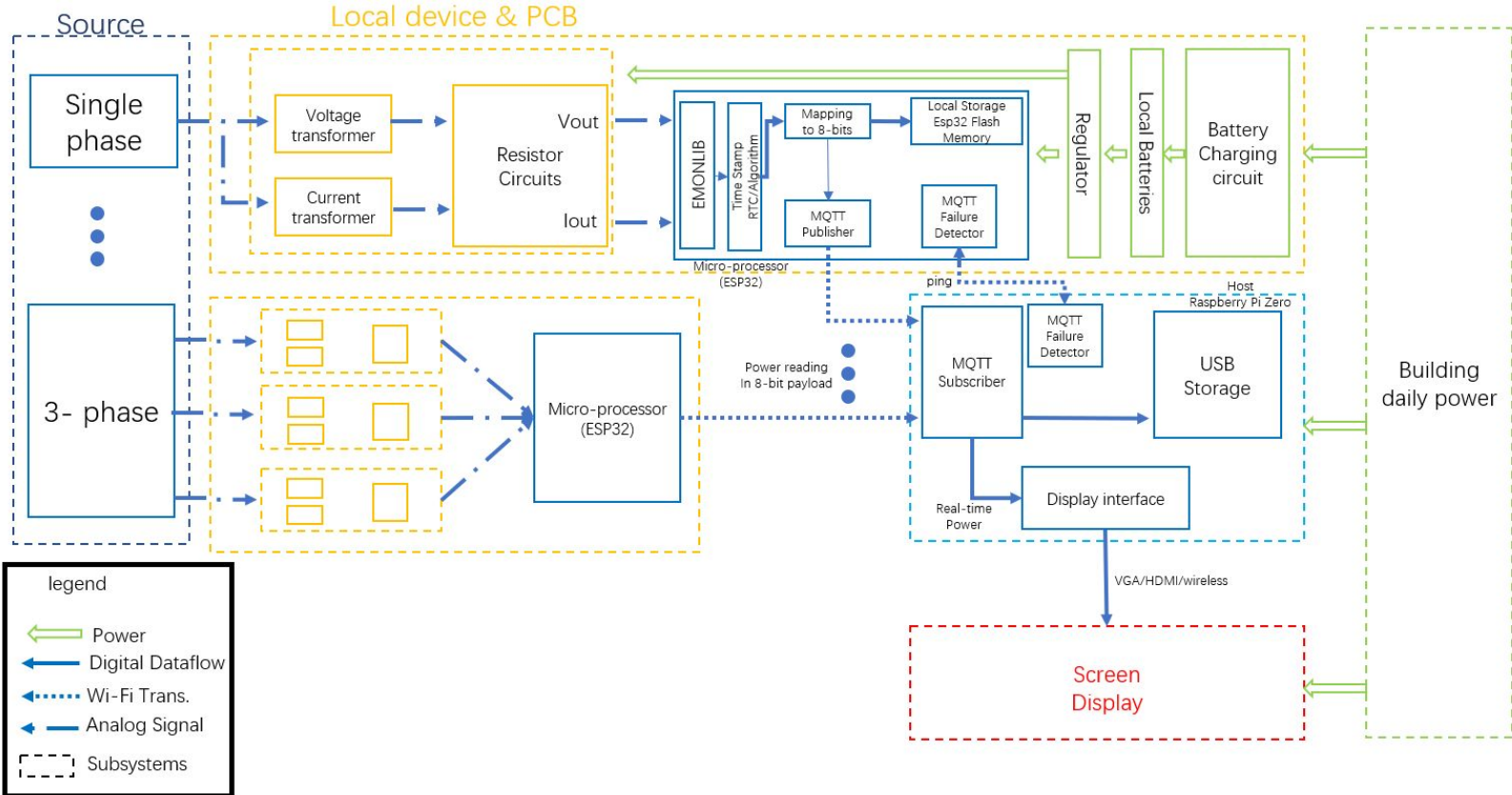

○ Subsystems

● Source Module

To the very beginning of our project design, the source module is representing the objects to be measured. Based on the information from the department, most of the rooms in ECEB use single phase power except ADSL, Open Lab, Optics and the power labs, ie.4020, 4024, 4026. Besides, 4020 and 4024 also have 240V DC power source that may need additional attention.

In our design, we now planned to build a measurement circuit design for single phase circumstances and for the 3-phase occasions, we would just apply the same circuits three times on each phase and add them together in the local microprocessor. The reason for doing this is that we do not want to waste resources on applying a complicated three phase design for single phase occasions, leaving the other two useless. Furthermore, we cannot ensure that the loads on each phase of the 3-phase labs are the same so measuring the power consuming in each phase seems to be our best solution.

Requirement	Verifications
<ol style="list-style-type: none"> 1. measure the single phase power consumption using one local device and 2. be able to add three to one miro-processor for 3-phase occasions. 	

● Local Device Module

● Voltage transformer:

The voltage transformer, chosen to be ZMPT107-1, isolates the measurement system from high voltage for safety and steps down the voltage from 208V to an appropriate range.

Requirement	Verifications
<ol style="list-style-type: none"> 1. provide isolation for safety. 2. Step down the voltage to an appropriate range. 	

● Current transformer:

The current transformer, chosen to be CTF-7RL-0400[1], can accept the primary current up to 400A and convert it to 5A secondary current with 1% accuracy and suitable frequency range.

Requirement	Verifications
Be able to step down the current from 200A~400A to about 5A	

- Resistor circuits:

The resistor circuit consists of a voltage divider circuit to convert the voltage to a measurable range(0~3.3V), which can be accepted by our local microprocessor, ESP32, and a resistor circuit to convert the current from 5A to 0~40mA. Since the basic voltage divider circuit, which only includes resistors, would cause a large linearity error due to the power dissipation in resistors and the following heat-up issues, we chose to include differential amplifiers to reduce the voltage and measure it. The gain of the differential amplifier can be adjusted based on our requirements by selecting proper values of resistors.

Requirement	Verifications
1. convert voltage to a measurable range(0~3.3v) 2. convert current to a measurable range(0~40mA) 3. error less than 1%	

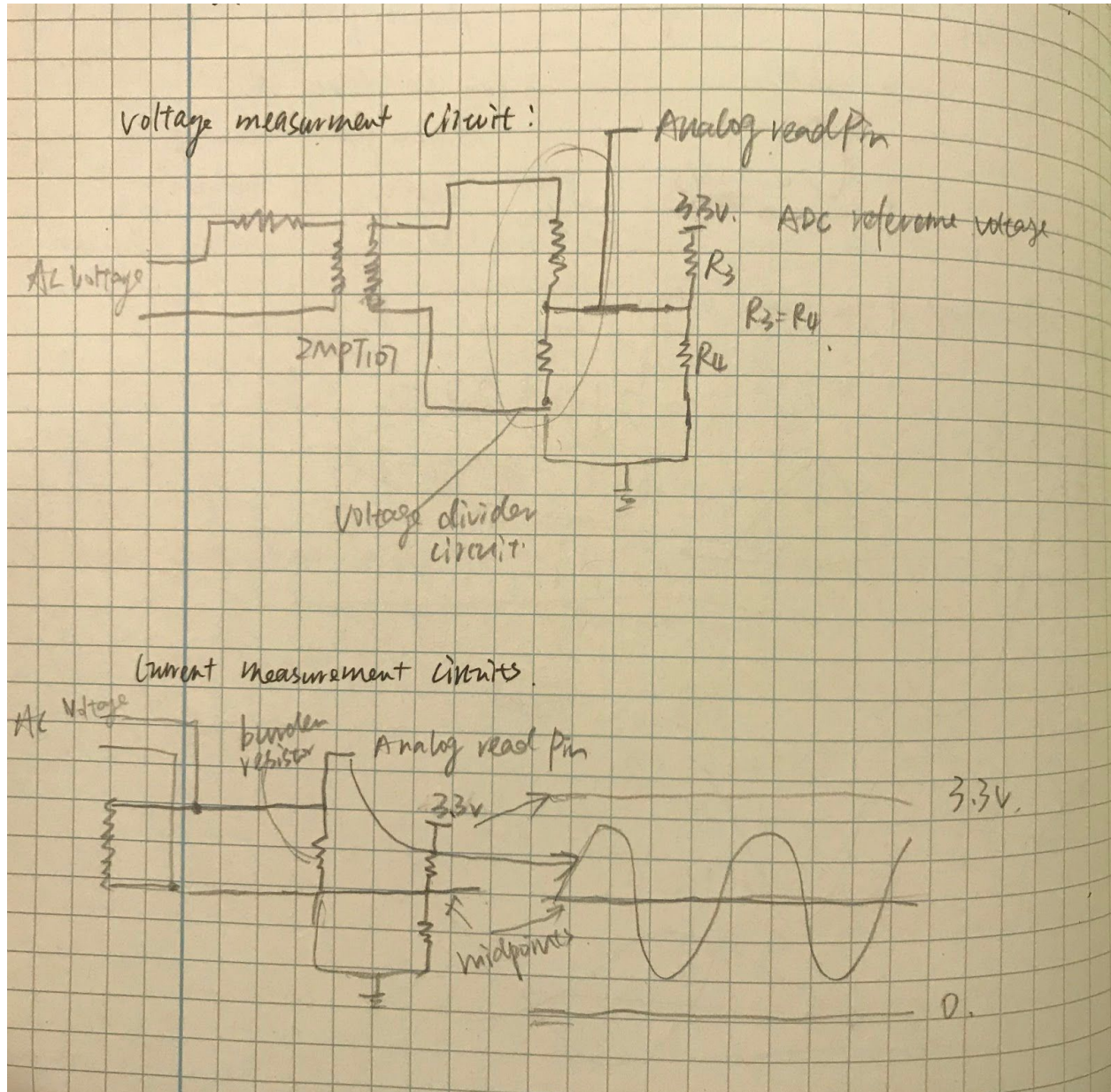

- Battery charging circuit:

The charger adapter switches the AC electricity from the outlets in the wall to DC electricity and also steps down the voltage from 110V to 5V. The battery will be charged fully through a charging IC.

Requirement	Verifications
1. convert AC electricity to DC electricity	
2. step down the voltage to about 5V	

3. charge the battery to 5V from wall outlets	
---	--

- Local Battery:

The battery must be able to power the resistor circuits and microprocessor continuously.

Requirement	Verifications
Be able to provide 2A at 5V	

- Regulator:

The variable voltage regulator, chosen to be LM317[2], can provide the 3.3V regulated voltage to microprocessor and required voltage to resistor circuits. The output voltage of this voltage regulator can be varied by changing the value of the resistor which is connected to the adjust pin of LM317.

Requirement	Verifications
1. provide 3.3V from a 5V source (battery)	
2. provide voltage to resistor circuits from 5V source	

- Microprocessor

We use ESP32 or similar as the microprocessor in our local device. The output from the circuit was read through the Analog Input. We will use EmonLib[3] to input signals into readable data then mark the timestamp with either real time clock or Lamport's timestamp for synchronizations. The power reading then will be mapped to 8 bit binary data. The data will be stored to local flash memory and also be packed into the payload to be sent to the host through MQTT protocol.

Requirement	Verifications
1. Has access to WiFi	
2. Affordable	

<p>3. Has enough memory size and write/erase cycles to store data locally for 40 hours</p> <p>4. Runs C language and preferably support arduino platform</p> <p>5. Reasonable heating and thermal resistance.</p>	
--	--

- **Host Module**

- **Server**

We use Raspberry Pi Zero as a server that accepts all data from local microprocessors through MQTT. The server is the center node in the communication system and will check all the local microprocessors for failure detections. It will store daily total power use to local storage and will also display real time power usage to Screen Display Module.

Requirement	Verifications
1. Could Run under 24/7 reliably	
2. Affordable	

- **External Storage:**

We connect an Hard drive to Raspberry Pi Zero to store the daily total energy for up to 4 years.

Requirement	Verifications
Reliable and Affordable	

- **Screen Display Module**

We will need a monitor to display the power results to the public. This could be any device that our department is willing to provide with us.

Requirement	Verifications
Wireless connection is preferable. VGA and HDMI are also acceptable.	

- Tolerance Analysis
- Cost Analysis(parts and labor)
- Schedule
- Ethics and Safety
- Citations and References