

# Vehicle Detection Cane

---

Team 42 - ECE445 - Spring 2020 - Project Proposal

Neva Manalil, Nick Halteman, Aditi Panwar

TA: Johan Mufuta

13 February 2020

# 1. Introduction

## 1.1 Objective

In 2016, pedestrian fatalities accounted for 16% of all traffic fatalities [1]. Those who are severely visually impaired are more susceptible to being involved in a traffic accident as they are not able to see oncoming traffic. Instead they either have a guide dog or rely on using a cane and their hearing to determine if an area is safe to walk. Gas fueled vehicles make a loud noise when driving by, but electric vehicles are virtually silent. With electric vehicles becoming more common it becomes more difficult for blind people to navigate as they cannot easily determine if a street is safe to cross.

Our solution for determining if an area is safe to walk is a battery-powered cane attachment that detects and alerts the user when a vehicle is passing in front of them. When activated by pressing a button, it uses a radar sensor to determine if there are cars or other fast moving vehicles in front of the user and alerts the user with vibration if it is not safe to walk.

## 1.2 Background

In an article by The Telegraph [2] on how a visually impaired woman was narrowly saved by a pedestrian from being hit by an electric vehicle, she mentioned that even her guide dog failed to recognise the car since there was no noise or fumes from the exhaust. This incident has really impacted her confidence of walking outdoors alone. This is just one of the many stories and electric cars are now viewed as a hazard for the visually impaired. There have been a number of solutions proposed to solve this problem. One of which is making the electric cars emit a warning sound [3]. This hasn't been implemented yet and might also be expensive to incorporate in the cars. Our solution is designed for visually impaired people to protect themselves from electric cars and give them more autonomy.

## 1.3 High-Level Requirements List

1. Device is able to detect relevant incoming vehicles up to at least 25m in front of the user.
2. Device is able to be powered for at least eight hours on standby mode.
3. The device is able to be easily operated by a visually impaired user.

## 2. Design

### 2.1 Block Diagram

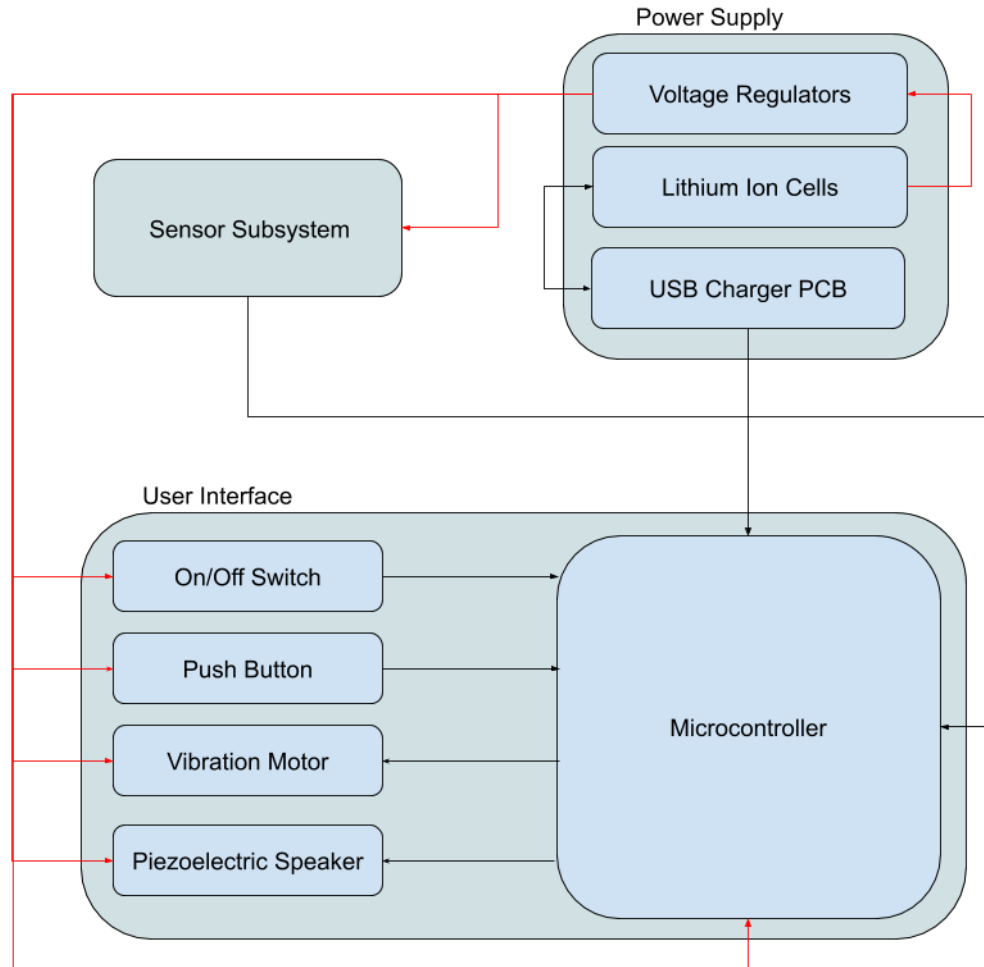

**Fig 1: Block Diagram**

Our design has three main subsystems for successful operation: a sensor subsystem, the power supply, as well as the user interface. The sensor subsystem is responsible for sensing incoming vehicles and processing the data received from the sensor to determine if there is an incoming vehicle. The power supply ensures that the system can be continuously powered for eight hours while in standby mode. Additionally, the power supply detects the low battery state and reports it to the user. The user interface allows the user to activate the sensor and receive feedback on vehicle detection and the battery state through a vibration motor and piezoelectric speaker. To interface between the three subsystems we use a microcontroller to process all of the signals and direct them to the correct feedback output.

## 2.2 Physical Design

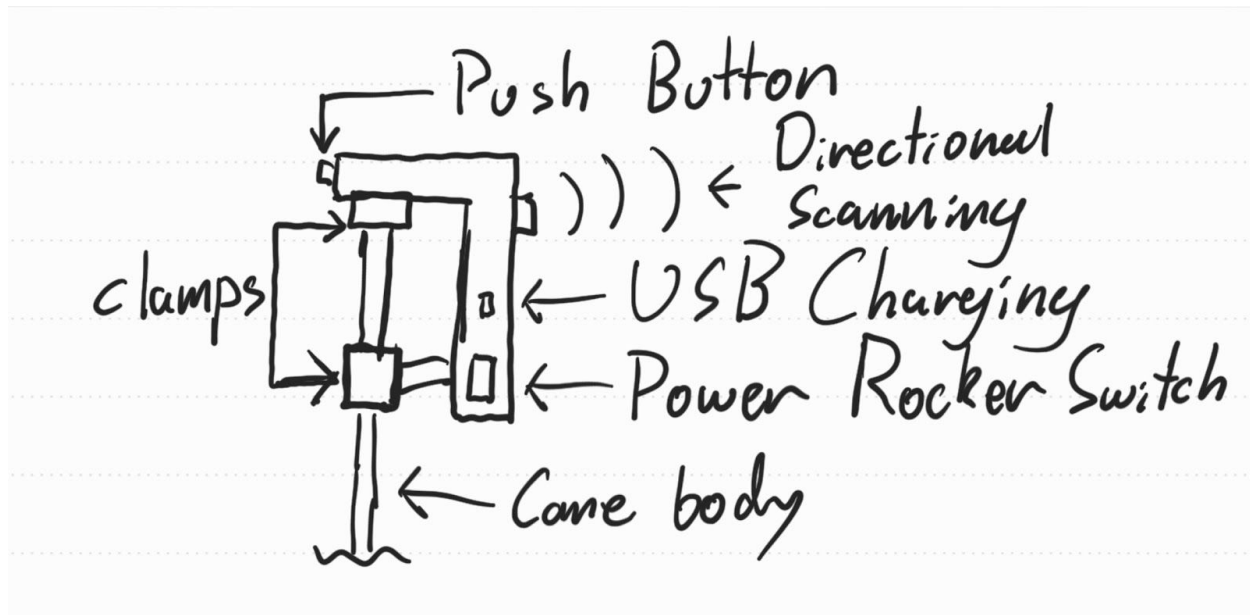

Fig 2: Physical Design

The system is designed to attach to the handle of a cane using clamps. The main body is detached from the cane shaft to allow it to be gripped the same during normal operation. The push button needs to be easily accessible during scanning, so it is positioned at the rear near the user's thumb. The push button's location also serves as a physical reference to aid in aiming the scanner.

## 2.3 Functional Overview

### 2.3.1 Sensor Subsystem

The sensor subsystem is responsible for using the doppler effect to identify moving vehicles. This technology has been in development in recent years for use in fully and partially autonomous cars. By emitting high frequency microwave "chirps" (above 77GHz) and "listening" for reflections off of objects, their general location and speed (the doppler effect) can be determined. Further processing can be performed to get more data on the object such as size and certain material characteristics (useful for differentiating between cars and other moving objects like people). An integrated automotive radar IC (which includes a transceiver, DSP, and microcontroller), will be used to emit and analyze radar data, and communicate the presence of moving vehicles to the user interface subsystem.

### **2.3.2 User Interface Subsystem**

The radar sensor lacks the ability to interface with motors, speakers, and buttons, so a user interface microcontroller will be responsible handling them. This microcontroller will communicate with the sensor subsystem through I2C and an appropriate I2C logic level shifter. This microcontroller will interface with a push button, rocker switch, piezoelectric speaker, and vibration motor to communicate information to the user and receive input. Each component's function is as follows:

- Push button: enable radar scanning when held
- Rocker switch: turn the device on and off
- Piezoelectric speaker: alert the user of low remaining battery
- Vibration motor: vibrate when moving vehicles are detected in front of the device

### **2.3.3 Power Subsystem**

The power system is responsible for providing set voltages to the other subsystems. 1.2v, 1.3v, 1.8v, and 3.3v are required by the sensor subsystem and 5v is required by the user interface subsystem. The power is provided by rechargeable battery cells which can be charged via USB.

## **2.4 Block Requirements**

### **2.4.1 Sensor Subsystem**

The sensor subsystem enables the device to detect moving vehicles. This will be accomplished using the AWR1843, an integrated radar transceiver, microcontroller, and DSP. The AWR1843 IC will communicate over I2C with the user interface microcontroller, to know when to scan and trigger vibration feedback.

*Requirement 1: Scanning is enabled and disabled according to I2C data from the user interface subsystem.*

*Requirement 2: I2C data is periodically sent to the user interface system indicating if a moving vehicle is within 25m in front of the sensor while scanning.*

*Requirement 3: While scanning, at least 10 scans must be completed per second.*

### **2.4.2 User Interface**

The user interface consists of a switch to turn the device on and off, a button to toggle the haptic feedback, and the audio and haptic feedback module through a piezoelectric speaker and a

vibration motor. The speaker must be able to play three different tones to signal the device turning on, turning off, and when low battery is detected.

### **On/Off Switch**

This switch is to turn the device on so that it's ready to detect the moving cars as soon as the push button is pressed.

*Requirement 1: Must not have accidental mechanical failures when dropped.*

*Requirement 2: Must cut power to the other subsystems.*

### **Push Button**

When the push button is pressed the vehicle detection will be active allowing for the vibration motor to alert the user of an approaching vehicle. When pressed, the device is in "active" state and will alert the user of incoming vehicles using the vibration motor. When the button is not held, the device is in "standby" state where the device is on but is not detecting vehicles.

*Requirement 1: The push button must be easily pressed and easily accessible during normal cane use.*

*Requirement 2: Must not have accidental mechanical failures when dropped.*

### **Vibration Motor**

This motor will vibrate the cane to inform the user that there is a vehicle moving towards them.

*Requirement: Vibrate intensely enough to notify the user.*

### **Piezoelectric Speaker**

Must be able to alert the user of the current power state of the device. It will play three different alert tones for when the device is turned on, turned off, and having low battery.

*Requirement: Capable of playing 3 easily differentiable tones.*

### **Microcontroller**

Must be able to take input from the doppler radar microprocessor and the voltmeter and output the appropriate signals to the vibration motor and the piezoelectric speaker. It will only output a signal for vehicle detection to the vibration motor when the push button is pressed.

*Requirement 1: Send a signal to the vibration motor when I2C data from the sensor subsystem indicates to do so.*

*Requirement 2: Periodically measure the voltage of the batteries and play a notification tone to signal low battery when the battery level is at 20% and 5% maximum capacity.*

*Requirement 3: Powers off the device when the battery reaches 5% maximum capacity after playing the tone.*

### **2.4.3 Power Supply**

The system will run off two 3.7v 18650 lithium ion cells running in series. A usb charger pcb (boards sometimes used for making portable phone chargers) will allow the cells to be charged with a usb cable. Voltage regulators will be used to produce the other voltages (1.2v, 1.3v, 1.8v, and 3.3v). A USB charger PCB will allow the cells to be charged with a USB cable.

#### **Voltage Regulators**

Each voltage regulator must be able to supply ample power for every component using that voltage.

*Requirement 1: Provide stable 1.2 +/- 0.05V at 1000mA from the battery cell voltage*

*Requirement 2: Provide stable 1.3 +/- 0.05V @ 2000mA from the battery cell voltage*

*Requirement 3: Provide stable 1.8 +/- 0.05V @ 850mA from the battery cell voltage*

*Requirement 4: Provide stable 3.3 +/- 0.1V @ 50mA from the battery cell voltage*

*Requirement 5: Provide stable 5.0 +/- 0.15V @ 1000mA from the battery cell voltage*

*Requirement 6: Must not exceed 100°C during operation.*

#### **Lithium Ion Cells**

A lithium ion battery must be able to keep the circuit powered.

*Requirement 1: Each cell must supply 2.2-3.7V and be able to provide at least 10A at this voltage.*

#### **USB Charger PCB**

USB charger PCB lets you recharge the batteries of the device.

*Requirement 1: Charge the lithium ion cells with power from USB.*

*Requirement 2: The cells must be charged evenly and remain within 50% of each other's capacities.*

## 2.5 Risk Analysis

The sensor subsystem definitely poses the greatest risk to successful completion of the project. Since if the sensor fails to detect a moving car from a distance of 100m, our main goal of the project wouldn't be achieved.

User-interface block and power subsystem should be able to work well together with the sensor subsystem to give the right inputs to the user. Since, false positives would make our product less reliable and affect the success of our project.

Also since this attachment will be on the cane, it needs to be able to work through all weather conditions which is why we have to make sure to cover our electrical components to avoid any system failure.

## 3. Ethics and Safety

There are a few safety hazards that must be taken into consideration with our product. As an electrical device designed to be used outdoors, the device will be subject to conditions such as potential water damage or being accidentally stepped on. We'll need to make sure the electrical component is well covered so no water leaks are possible.

We are using a battery to power all our other subsystems so we need to make sure that the power subsystem is safe and doesn't harm the product or the user.

Since our product caters to the need of visually impaired, we must be realistic in stating claims about the features and success of the product, in accordance with IEEE Code of Ethics #3: 'to be honest and realistic in stating claims or estimates based on available data' [4].

For the success of this product we will make sure we consider all the constructive criticism and suggestion on improving the performance which adheres to the IEEE Code of Ethics #7: 'to seek,



accept, and offer honest criticism of technical work, to acknowledge and correct errors, and to credit properly the contributions of others' [4].

## 4. Citations and References

[1] NHTSA, "Travel Safety Facts", 2018 [Online]. Available: <https://crashstats.nhtsa.dot.gov/Api/Public/ViewPublication/812493>. [Accessed: 13-Feb-2020]

[2] M. Write, 'Electric cars are 'silent killers' visually-impaired woman warns after near miss', *The Telegraph*, 2019. [Online]. Available: <https://www.telegraph.co.uk/news/2019/11/20/electric-cars-silent-killers-visually-impaired-woman-warns-near/>. [Accessed: 13-Feb-2020].

[3] SINTEF, 'Electric cars are a hazard for blind people', *Phys.org*, 2018. [Online]. Available: <https://phys.org/news/2018-10-electric-cars-hazard-people.html>. [Accessed: 13-Feb-2020].

[4] IEEE, "IEEE Code of Ethics", 2020. [Online]. Available: <http://www.ieee.org/about/corporate/governance/p7-8.html/>. [Accessed: 13-Feb-2020].