

Lecture 1: ECE110 *Introduction to Electronics:* *Key Intro Concepts*

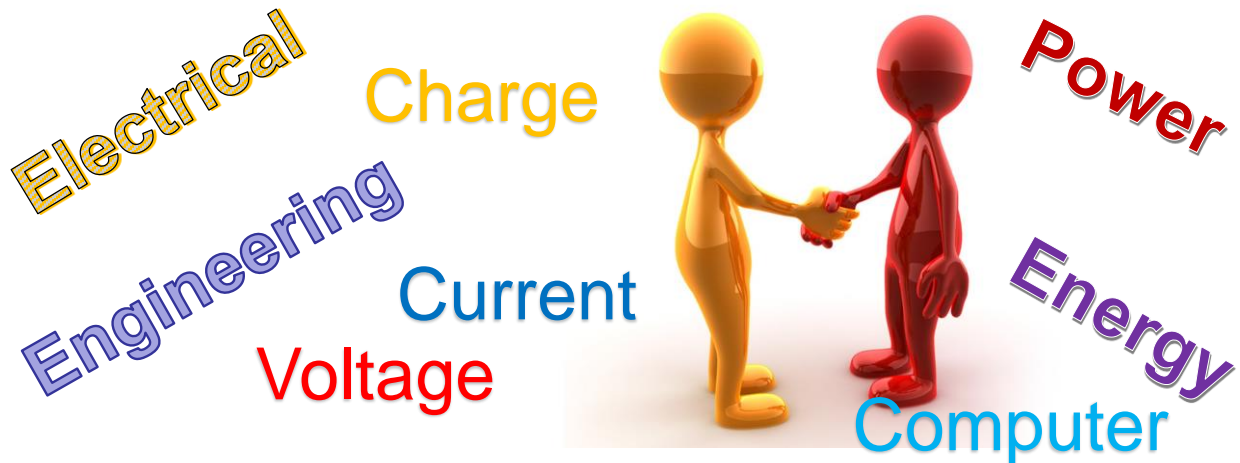

1

Recommended learning opportunities

- **Workshops** (as announced each week)
- **Office Hours** Room 1005 (near lab), TBD
- **CARE** (Center for Academic Resources in Engineering) Grainger Library
- **Honors projects** targeting James Scholars, ECE110+ECE120

Encountering various difficulties? Contact your Instructor, lab TA, or the advising office on the second floor (2120 ECEB)!

2



The Field of Study Defined

“**Engineers** use the knowledge of mathematics and natural sciences gained by study, experience, and practice, applied with judgment, to develop ways to economically utilize the materials and forces of nature for the benefit of mankind.”

- ABET (Accreditation Board for Engineering and Technology)

Electrical engineering (EE) is a field of **engineering** that generally deals with the study and application of electricity, electronics, and electromagnetism.

- Wikipedia

3



A short history of Electrical Engineering

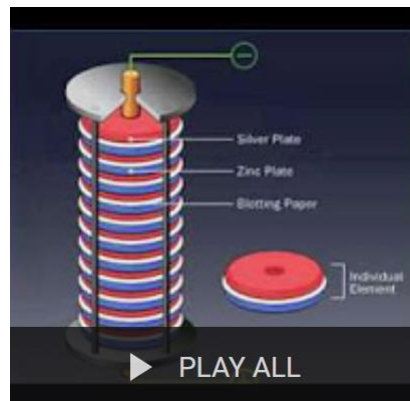

4

Charge

- Charge is measured in coulombs (C)
- Capital or lowercase "Q" is the variable typically used to represent charge
- an electron is a charged subatomic particle
- the coulomb is extremely large compared to the charge of a single electron

$$\frac{-1.6 \times 10^{-19} C}{\text{electron}} \quad (\text{notation change}) \quad = \quad \frac{-1.6 \text{ e} - 19 \text{ C}}{\text{electron}}$$

- Electronics is much more than just movement of electrons

5

Current: the rate at which Charge moves

- Current is measured in units of amps (A)
- Capital or lowercase "I" is the variable typically used to represent current...it means *intensity*.
- Electric current is the flow of electric charge in time (C/s)

$$i(t) = \frac{dq(t)}{dt}$$

- The ampere is the unit of electric current

$$1 A = 1 C/s$$

- Current is measured by an *ammeter*



Image is public domain.

6



"DC" Current

For *constant* rates called "Direct Current" or "DC", we typically use capitalized variables and can replace the differential with observations in some time, Δt .

$$I = \Delta Q / \Delta t$$

the Δ means "the change in"

7



Charge and Current

Help Sheet:

$$\frac{-1.6 \text{ e} - 19 \text{ C}}{\text{electron}}$$

$$I = \frac{\Delta Q}{\Delta t}$$

$$1 \text{ A} = \frac{1 \text{ C}}{1 \text{ s}}$$

Question: What is the charge of 1 billion electrons?

- A. 160 e-12 C
- B. 16 e-12 C
- C. 1.6 e-12 C
- D. 1.6 C
- E. 160 C

Q: A "typical" electronics circuit might have 1 billion electrons pass a cross section of a wire every nanosecond, what is the electric current in amps?

- A. 0.00000016 A
- B. 0.160 A
- C. 1 A
- D. 1e-9 A
- E. 160e-12 A

8

The Ammeter

To use an ammeter to measure current, the circuit must first be “broken” and the ammeter inserted between the detached wires. The ammeter repairs the circuit and the current being measured is forced to flow through the ammeter.

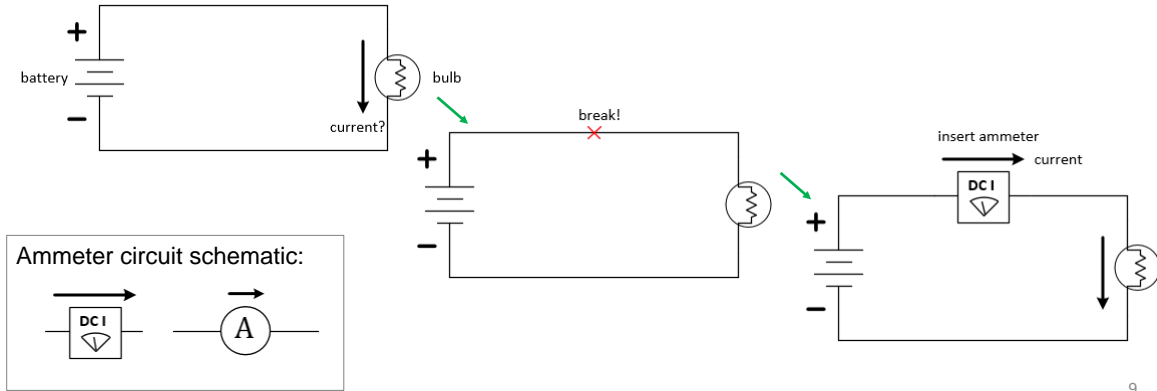

9

The Ammeter

We say the ammeter is connected in series. Any devices connected in a way to force them to share the same current are said to be connected in series.

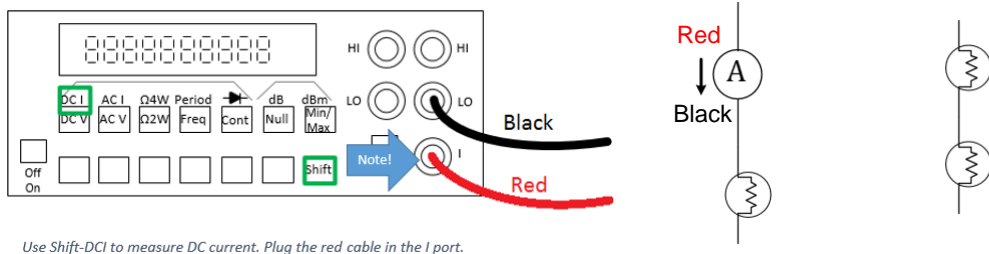

10

Voltage

- Voltage across two points in space is the energy it requires to move each “unit” of charge between those two points. Alternately, it is the energy released when one unit of charge is allowed to move between two points in space (moving from a higher potential to a lower potential).
- As an example, it should take no energy (0 volts) to move charge through an *ideal conductor* (zero-resistance) connected in a loop. As a second example, a 9-volt battery delivers 9 Joules of energy to each Coulomb of charge it moves.
- Voltage, as seen by the description above, is *differential* (measured between two points) and not absolute (cannot be measured at a single point without a reference).
- In many circuits, voltage potential is provided by a battery. Think of a battery “pushing” electrons through a circuit (perhaps a light bulb).
- Voltage is measured with a voltmeter in units of volts [V].

$$V = \frac{\Delta E}{\Delta Q}$$

11

The Voltmeter

To use voltmeter, the meter’s probes are placed across the device whose voltage value is desired. The circuit is **not** broken-and-repaired when using the voltmeter. The meter is merely placed between two circuit locations.

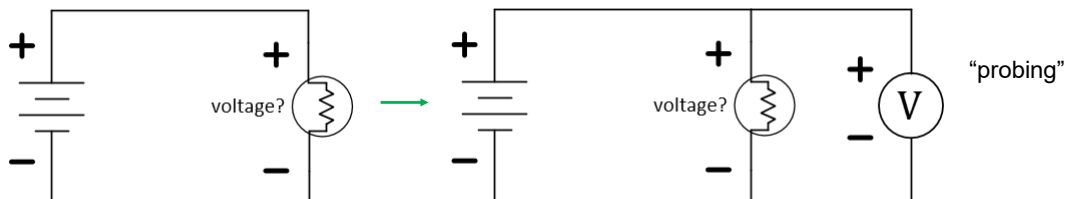

Voltmeter circuit schematic:

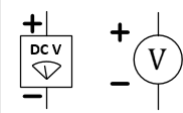

12

The Voltmeter

We say the voltmeter is connected in parallel. Any devices connected in a way to force them to share the same voltage are said to be connected in parallel.

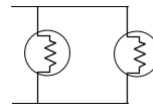
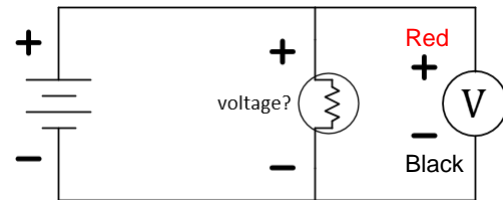
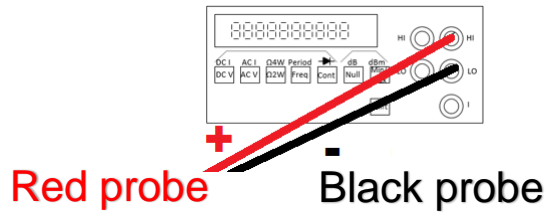

13

**(A) Series, (B) Parallel,
(C) Neither, or (D) Both?**

Q:

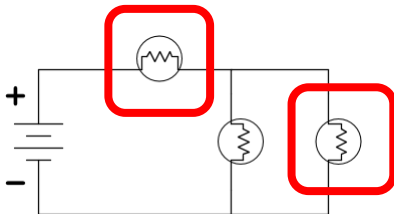

Q:

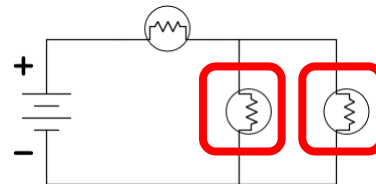

14

(A) Series, (B) Parallel, (C) Neither, or (D) Both?

Q:

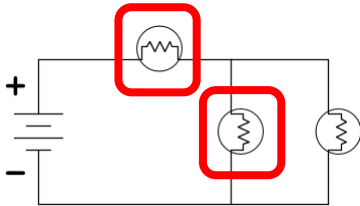

Q:

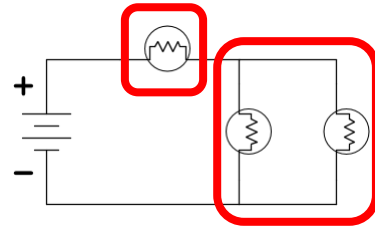

15

ECE110 Laboratory

- **Measure** device data
- **Model** behavior
- **Make** interesting circuits
- **Master** design of your own circuits



The laboratory provides a hands-on opportunity to both learn and to showcase your skills!

16





Required

- ECE Supply Center
 - ECE110 Electronics Kit
 - i>clicker/app
- Online (courses.engr.illinois.edu/ece110)
 - ECE110 Lecture Slides (IUB bookstore)
 - ECE110 Lab Procedures (IUB bookstore)



Recommended

- ECE Supply Center
 - Voltmeter 
 - Multipurpose wire stripper 
 - Arduino (or RedBoard) + cable



17



Schedule

- Homework
 - First assignment due on 2nd Wednesday of the semester
 - Online via **PrairieLearn**
 - Discussion of problems and course announcements on **Piazza**- Do not post solutions! Enter hints and links to materials that will help other students understand the material better!
 - Due **Wednesdays at 11:59 pm**. Get it done early!
 - Office Hours...To be posted soon

18



Schedule

- Lab
 - Labs start on Monday, January 27
 - Purchase ECE110 Electronics kit in ECE Supply Center
 - Purchase Lab Procedures at IUB
 - Prelab assignments due at the beginning of each meeting

19



L1 Learning Objectives

- (L1a) Compute relationships between charge, time, and current.
- (L1b) Define voltage.
- (L1c) Identify series and parallel elements in a circuit.
- (L1d) Describe how to insert an ammeter and a voltmeter into a circuit.

$$I = \frac{\Delta Q}{\Delta t} \quad V = \frac{\Delta E}{\Delta Q}$$

20

Lecture 2: Current and Voltage Measurements

- Measuring current: galvanometer
- Measuring voltage: comparators
- Current-vs-Voltage plots
- IV characteristics
- Ohm's Law
- Cylindrical Conductors
- IV-based modeling

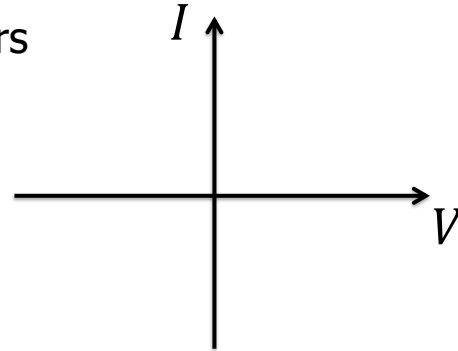

21

Electric current deflects a compass needle

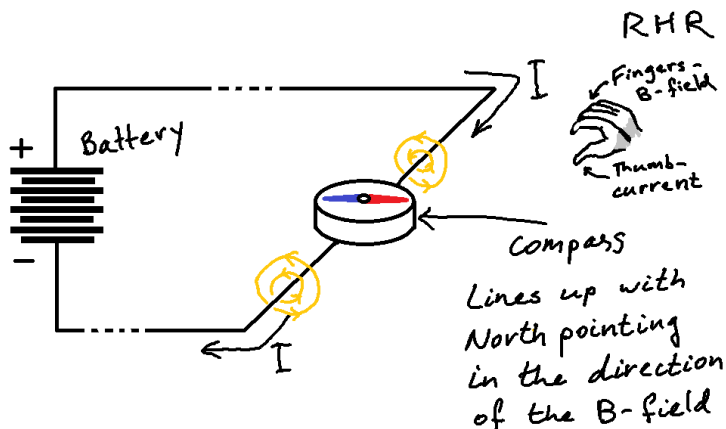

In History...

Hans Christian Oersted's observation of this effect in 1820 may have surprised him during his lecture demonstration to advanced students. Detailed experiments followed later.



Image in Public Domain

22

Galvanometer measures current

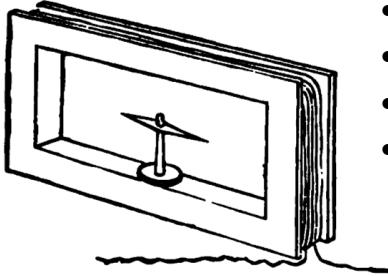
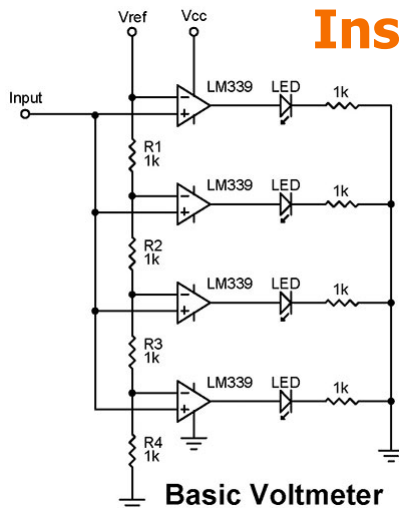

Image from book: Electrical Measurement and the Galvanometer: Its Construction and Uses, by T. D. Lockwood, New York: J. H. Bunnell and Co., 1890
Image in Public Domain.

- Each of N windings in coil adds to magnetic field, B
- B counteracts Earth's magnetic field
- More current – bigger angle of needle
- More sophisticated galvanometers came later

23

Inside a Voltmeter



- Compares the input voltage to known voltages.
- Uses "voltage dividers" and "comparators"
- This is stuff we will understand through ECE110!

Image from <https://www.nutsvolts.com/questions-and-answers/led-voltmeter>

24



Current vs Voltage Measurements

- Current-vs-Voltage plots
- IV characteristics
- Ohm's Law

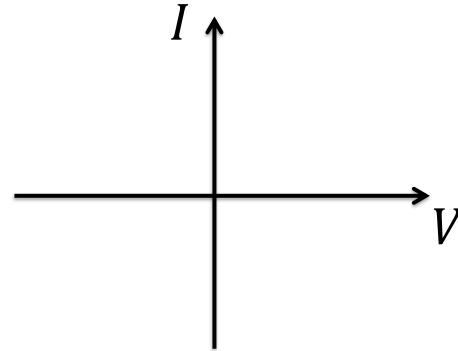

25



Ohm's law models the current and voltage relationship in conductors

Motivated by applications of long-distance telegraphy, Georg Ohm (~1825) conducted careful experimentation to find this widely-used approximate mathematical model:

$$I = \frac{V}{R}$$

where $R = \rho \frac{l}{A}$ is resistance of a *conductor* (e.g. wire)

with length, l , and area A , and where ρ is *resistivity* - a material parameter

26

Resistors also known as Conductors

$$I = \frac{V}{R}$$

$$R = \rho \frac{l}{A}$$

Question: Find the diameter of one mile of Cu ($\rho = 1.7 \times 10^{-8} \Omega m$) wire when $R = 10 \Omega$.

- A. $1.7 \mu m$
- B. $1.9 mm$
- C. $1 cm$
- D. $19 cm$
- E. $1.7 m$

Q: If the resistance of one wire is 10Ω , what is the resistance of two such wires in parallel?

- A. 2.5Ω
- B. 5Ω
- C. 10Ω
- D. 20Ω
- E. 40Ω

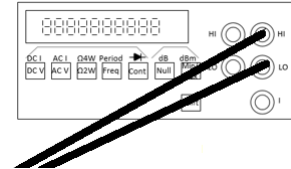

Our ohmmeter uses the same connections but different settings than the voltmeter! Polarity doesn't matter for Ohms. Why?

27

The Relationship between Current and Voltage is very revealing for many devices

Devices composed of voltage sources, current sources, and resistors have "IV" relationships described by a simple line:

$$I \approx mV + b$$

where m is the slope and b is the intercept of this line on the I (current) axis.

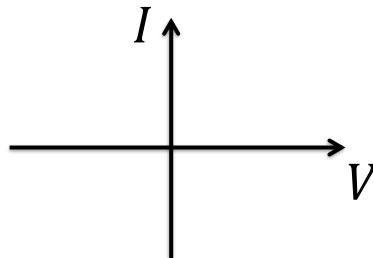

28

Linear IV Characteristics

$$I \approx mV + b$$

Example: For a "**resistor**", zero voltage means zero current and the intercept is at the origin ($b = 0$).

Physical

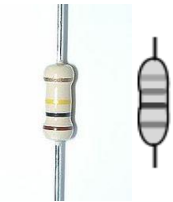

Circuit schematic

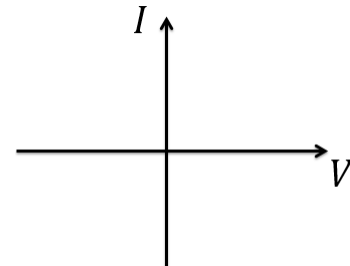

29

Linear IV Characteristics

$$I \approx mV + b$$

Example: For an **ideal current source**, $m = 0$ such that $I = b$ independent of V (the voltage across the current source).

Physical

?

(later...)

Circuit schematic

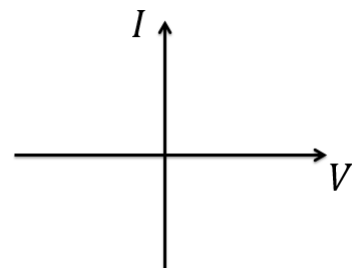
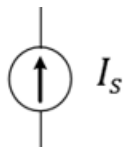

30

Linear IV Characteristics

$$I \approx mV + b$$

Example: For an **ideal voltage source**, $V = V_S$ and the current through the source is unconstrained (the limit as $m \rightarrow \infty, b \rightarrow -\infty$).

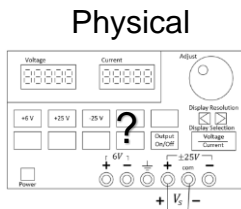

Circuit schematic

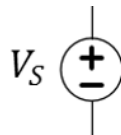

“Banana” cables and “alligator” clips are used to make connections to the sources and meters in the lab.

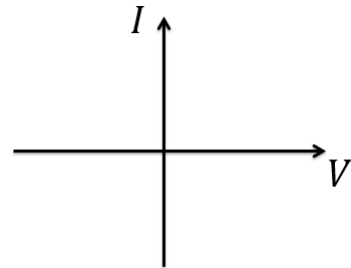

31

Linear IV Characteristics

$$I \approx mV + b$$

Example: What happens with a non-ideal voltage source, for example, a **battery**?

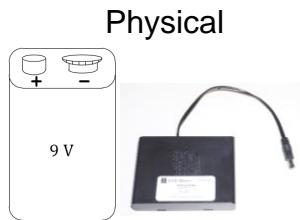

Circuit schematic

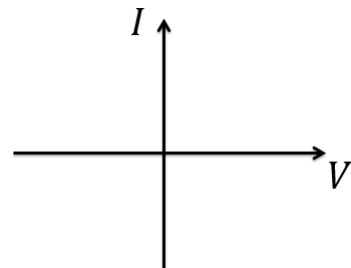

32

Resistance can be used in device models

- Lengths of wire
- Incandescent bulbs
- Heating elements
- Battery terminals
- Stalled motors
- Fuses, etc.

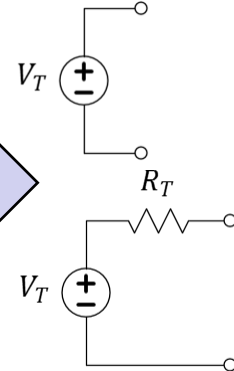
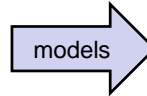
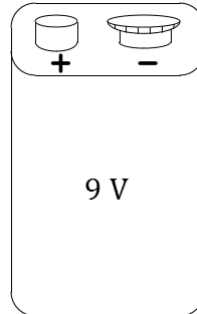

Q: If a 9 V battery provides (at maximum) a current of 2 A, what is its modelled “internal” resistance, R_T ?

- A. 0Ω
- B. 2Ω
- C. 4.5Ω
- D. 18Ω
- E. $\infty \Omega$

33

Linear IV Characteristics

Physical

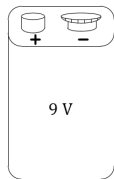

Circuit schematic

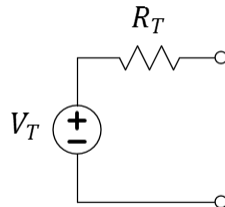

IV plot

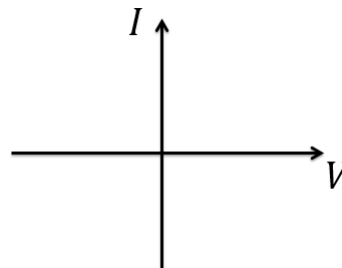

IV equation

$$I = mV + b$$

Q: For what region of the empirical data might we want the model to best fit?

- A. Near the intersection with the I-axis.
- B. Near the intersection with the V-axis.
- C. Halfway between the two axis.
- D. Minimize the average error between the equation’s prediction and all data.
- E. Minimize the maximum error between the equation’s prediction and all data.

34



Feeling Sick? Can't make class?

Please, don't risk infecting others.



Lab: Notify your lab TA (not me!) before lab to request an excused absence. Up to two may be granted.

Lecture: Do nothing. Missed lectures will be counted towards your 20% *excused* absences.

Forgot your i>clicker? Do nothing; will be counted towards your 20% excused absences.

35

L2 Learning Objectives

- Compute resistance of a cylindrical conductor given dimensions.
- Relate voltage and current for an "Ohmic" conductor.
- Use Ohm's Law to model the internal resistance of a physical battery.

36

Lecture 3: Professional Development; Circuit Models and Schematics

- Professional Development: Teamwork and Growth
- Circuit Modeling and Schematics
- Model and solve very simple (one loop) circuits
- Examples: Broadcast Telegraphy, Decorative Lights

37

Teamwork

- Contrary to the movies, most engineers do not work in isolation!
- Design teams must be functional to be effective

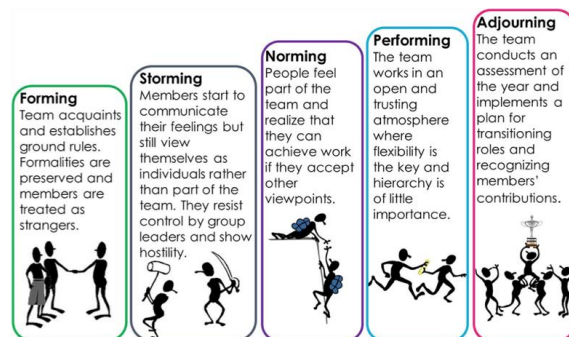

image credit: <https://culclzha.wordpress.com/2017/10/09/the-challenges-of-managing-a-diverse-team/>

CATME is a tool we will use in lab to assist in team formation and feedback to help students learn how to move more quickly to the "performing" stage of the team activities!

Tuckman's Theory. (Forming, Storming, Norming, and Performing: The Stages of Team Building, 2015)

38



IEEE Code of Ethics⁽²⁰¹²⁾

IEEE – Institute of Electrical and Electronics Engineers

We, the members of the IEEE, in recognition of the importance of our technologies in affecting the quality of life throughout the world, and in accepting a personal obligation to our profession, its members and the communities we serve, do hereby commit ourselves to the highest ethical and professional conduct and agree:

39



IEEE Code of Ethics

1. to accept responsibility in making decisions consistent with the **safety, health, and welfare of the public**, and to disclose promptly factors that might endanger the public or the environment;
2. to avoid real or perceived **conflicts of interest** whenever possible, and to disclose them to affected parties when they do exist;
3. to be **honest** and realistic in stating claims or estimates based on available data;
4. to reject **bribery** in all its forms;
5. to improve the **understanding of technology**, its appropriate application, and potential consequences;

40



IEEE Code of Ethics

6. to maintain and improve our technical **competence** and to undertake technological tasks for others only if qualified by training or experience, or after full disclosure of pertinent limitations;
7. to seek, accept, and offer honest **criticism** of technical work, to acknowledge and correct errors, and to **credit** properly the contributions of others;
8. to **treat fairly all persons** regardless of such factors as race, religion, gender, disability, age, or national origin;
9. to **avoid injuring others**, their property, reputation, or employment by false or malicious action;
10. to assist colleagues and co-workers in their **professional development** and to support them in following this code of ethics.

41



Avoid Dilemmas and Grow Professionally!

Picking Up the Slack...search at Santa Clara University:

<http://www.scu.edu/>

❖ Often called a "hitch-hiker" scenario...

Q: What do you feel Greg should do?

- A. Value the relationship, grade Natalie the same as the group.
- B. Greg is not a babysitter...give Natalie the grade she earned.
- C. Give Natalie a worse grade than the group, but better than she deserved.
- D. Talk to Natalie before deciding which grade to give.
- E. Talk to the Instructor before deciding which grade to give.

Q: What would you have done differently?

**Good Course:
ECE 316
Ethics and Engineering
(also Adv. Composition)**

42

Circuit Model For a Telegraph Loop

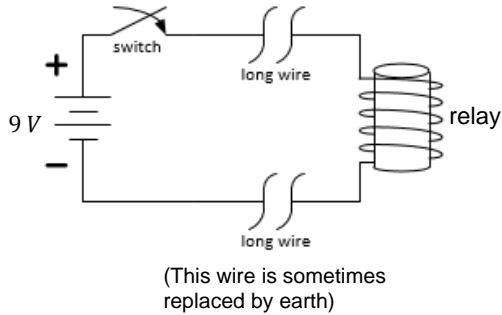

Q: If a 9 V battery with 4 Ω contact resistance is used and the relay has 80 Ω and the wire has 10 Ω/mile, what is the maximum telegraph distance which will result in a 50 mA current through the relay circuit loop?

- A. 0.5 miles
- B. 5 miles
- C. 10 miles
- D. 100 miles
- E. 500 miles

Broadcasting: multiple ways to wire relays

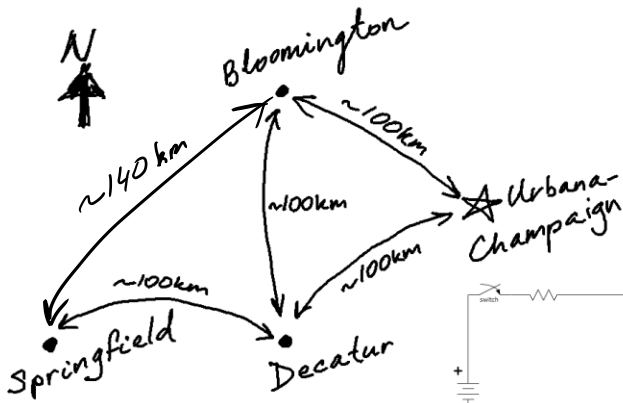

i>clicker Q:
Which method (A, B, or C) is a parallel combination of towns?

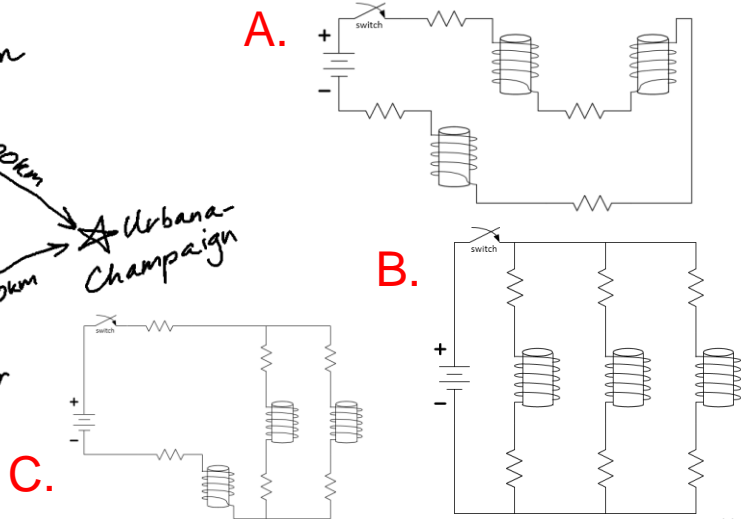

Decorative lights: multiple ways to connect bulbs to the wall power plug

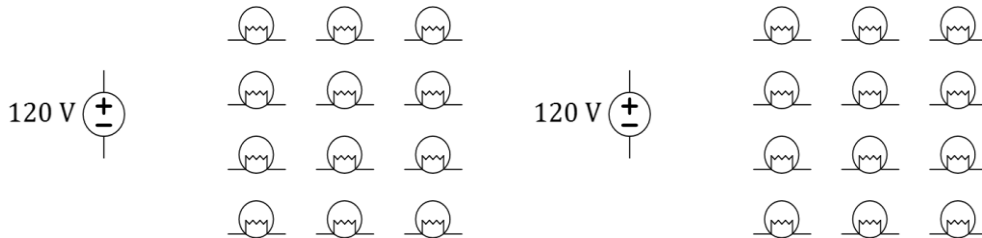

Q: Draw a circuit for 12 lightbulbs connected in *series* in one loop.

Q: Draw a circuit for 12 lightbulbs connected in two *parallel* branches.

45

L3 Learning Objectives

- Identify five stages of team building
- Explain how a code of ethics can aide in professional growth
- Develop a plan to avoid an ethical dilemma in the laboratory
- Draw source and resistor circuits to model real-world problems

Explore More!



ECE 329 Fields and Waves I
ECE 350 Fields and Waves II

A wave traveling rightward along a lossless transmission line.
Black dots represent electrons, and arrows show the electric field.
Image in Public Domain under CC0

Source: https://en.wikipedia.org/wiki/Transmission_line

46



Policies

- Lab attendance is **mandatory**, each and every week
- **No food/drink in 1001 ECEB**
- Food and drink **allowed in 1005 ECEB**, only. Since this room is used for office hours, take your book bag with you into the lab.
- Lecture attendance is semi-mandatory...see next slide

47



Electrical Engineering inseparable focus areas

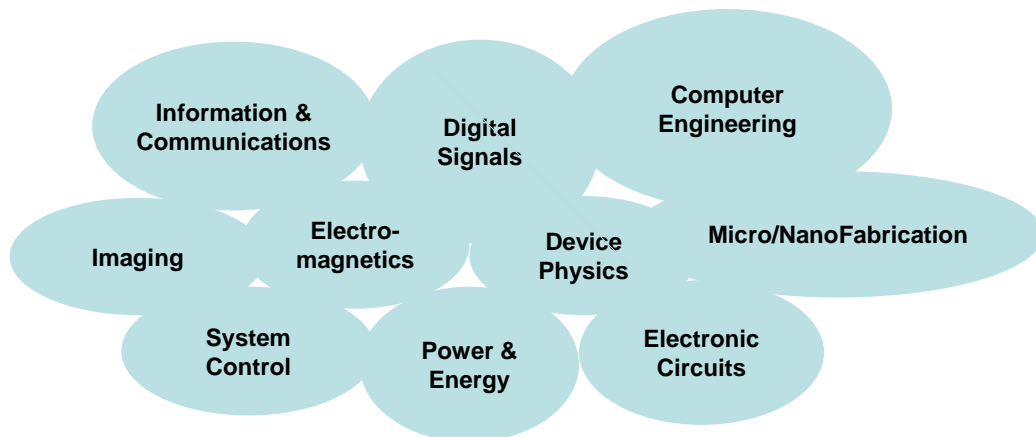

48



Lecture 4 : Power and Energy

- Relationship between Voltage and Energy
- Relationship between Power and Energy
- Energy Efficiency

49



Voltage and Energy

- **Energy** is **the ability to do work**, measured in joules (J), BTUs, calories, kWh, etc.
- **Voltage** is **the work done per unit charge** (eg. J/C) against a static electric field to move charge between two points
- Also, 1 volt ($1 V$) is the electric potential difference between two points that will impart $1 J$ of energy per coulomb ($1 C$) of charge that passes through it.

$$V = \frac{\Delta E}{\Delta Q}$$

$$\Delta E = \Delta Q V$$

Q: A certain battery imparts 480 pJ to every 1 billion electrons. What is its voltage?

- A. 1.5 V
- B. 3 V
- C. 6 V
- D. 9 V
- E. 12 V

50



Voltage and Energy

$$E = Q V$$

Tesla Model S

Q: What is the charge moved through 400 V (EV battery) to provide 800 kJ of energy?

- A. 2 mC
- B. 2 C
- C. 2 kC
- D. 2 MC
- E. 2 GC

Q: What is the average current if the energy in Q4 is provided in five seconds?

- A. 1 μ A
- B. 4 mA
- C. 4 A
- D. 10 A
- E. 400 A

51



Energy and Power

Power is the rate at which energy is transferred.

Power is *(rate of charge flow) \times (potential difference)*

Power is *current \times voltage*

$$P = \frac{\Delta E}{\Delta t} = \frac{\Delta Q}{\Delta t} V = I V$$

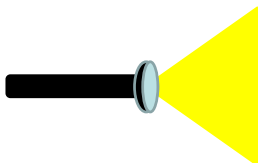

Q: A flashlight bulb dissipates 6 W at 2 A. What is the supplied voltage?

- A. 1.5 V
- B. 3 V
- C. 6 V
- D. 9 V
- E. 12 V

52



Energy in General

- Energy is **ability to do work**
- Energy comes in many forms
- Energy is conserved (can change forms)

Examples: heat, light, electrical energy, chemical, mechanical (e.g. potential, kinetic), mass, etc...



53



What is "work" ?

- drive to Chicago
- move a couch
- cook an egg
- lift a camel
- launch a satellite
- stay awake in lecture (try!)
- electrocute somebody (don't!)
- send an email (to Brazil or Urbana?)
- *write down some of your own ideas*



54



Energy Storage

- Mechanical Energy

Kinetic Energy

Potential Energy

- Electrical Energy Storage

Capacitors

Batteries

- Conservation of Energy

$$E_{input} = E_{useful} + E_{waste}$$

55



Efficiency

- Distance: 200 km
- Elevation Drop: 44 m
- Where is the waste?

$$E_{input} = E_{useful} + E_{waste} = \eta E_{input} + (1 - \eta) E_{input}$$

η is called “efficiency”

$(1 - \eta)$ is called “losses”

Explore More!

Elon Musk is in the news much these days with Hyperloop One. What are some benefits of Hyperloop technology? What are some cons?

56



Driving to Chicago...accounting

Q: What minimum energy does it take to accelerate a 2200 kg mass (car) from 0 to 60 mph?

- A. 8 mJ
- B. 1 J
- C. 80 J
- D. 1 kJ
- E. 800 kJ

Q: What is the energy *input* needed if the engine/drive train losses are 70%?

- A. 2.6 mJ
- B. 2.6 J
- C. 26 J
- D. 2.6 kJ
- E. 2.6 MJ

Q: A certain gas car gets 50 km/gal (avg). How much energy does it take to get to Chicago?

- A. 500 mJ
- B. 500 J
- C. 500 kJ
- D. 500 MJ
- E. 500 GJ

57



Loading camels: different power; same E!

Definition of power: $P = \frac{\Delta E}{\Delta t}$ is rate of energy...

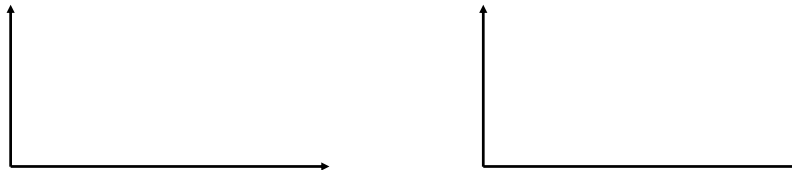

Loading Camels: What is the average power needed to lift 500 kg by two meters every minute?

Acceleration of Tesla car: What is the power needed to expend 800 kJ in five seconds?

- A. 160 mW
- B. 160 W
- C. 160 kW
- D. 160 MW
- E. 160 GW

58



L4 Learning Objectives

- a. Compute power, energy, and time, given two of three
- b. Solve energy transfer problems involving mechanical potential and kinetic energy as well as efficiency (or wasted energy) considerations
- c. Perform unit conversions for energy, charge, etc
- d. Use a power vs. time plot to describe the difference between power and energy



Lecture 5: Circuit Devices in the Lab

- Describe resistors and discuss power limitations of physical resistors
- Describe capacitors and the amount of energy they can store
- Describe batteries and how to compute usage based on their energy rating
- Describe the Transistor and why it is important to us
- Describe the MOSFET and a simple model for it
- Describe an Invertor and a simple model for it

61



Uses of Resistors

- Current limiting
 - Examples: Preventing LED burnout; slow your motor
- Prevent a node from “floating” by either “tying it high” or “tying it low”
 - Example: Using a button for binary input
- Divide a voltage by a known fraction
 - Example: Voltage comparison in a digital voltmeter
- Divide a current by a known fraction
 - Example: Scaling current to the range of a galvanometer in an ammeter
- Tune a circuit’s “time constant”
 - Example: RC filter design

62

Resistors are devices that obey Ohm's Law

- Resistors always dissipate power; they heat up
- Resistors do not store or deliver (DC) energy
- Using Ohm's Law...

$$P = I V = \frac{V^2}{R} = I^2 R$$

In History...

Henry **Cavendish** conducted similar experiments over 40 years earlier than Georg **Ohm** using Leyden jars for voltage sources and the shock felt by his body as an *ad hoc* ammeter!



Image in Public Domain

63

Resistors

$$P = I V = \frac{V^2}{R} = I^2 R$$

- Q: What power is dissipated by a 100 Ω resistor when a 6 V drop is measured across it?
- A. 360 mW
 - B. 160 W
 - C. 360 kW
 - D. 160 MW
 - E. 360 GW

- Q: A 100 Ω resistor is rated at 0.25 W. What is its maximum rated current?
- A. 50 mA
 - B. 400 mA
 - C. 50 A
 - D. 400 A
 - E. 50 kA

64

Capacitors: store electrical energy

$C = Q/V$ – capacitance is the charge-to-voltage ratio of a capacitor

$$E_{\text{capacitor}} = \frac{1}{2} CV^2$$

In History...

The first device for storing electrical energy became known as Leyden Jar after the city in which it was built (1745). It had a capacitance of about 1 nF.

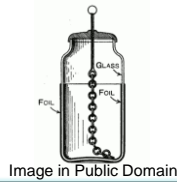

Image in Public Domain

In History...

Yes, **Benjamin Franklin** collected electrostatic charge from a storm using a kite in 1752, but also formulated the *principle of conservation of electric charge* and coined the terms “positive” and “negative” with respect to the charge carriers (current).



65

Capacitors

Q: At what voltage would a 1 nF capacitor have the energy to lift 100 kg (a camel, perhaps?) by 2 cm?

- A. 200 mV
- B. 250 mV
- C. 200 V
- D. 250 V
- E. 200 kV

66

Example Uses of Capacitors

- Smoothing out voltages
- Separating or combining AC and DC

67

Efficiency of Charging a Capacitor

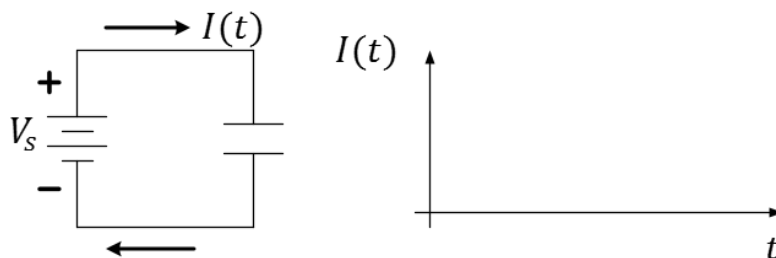

- $\Delta E_{battery} = \Delta E_{capacitor} + \Delta E_{waste}$
- $\Delta E_{waste} \geq \frac{1}{2} CV^2$
- $\Delta E_{battery} \approx \frac{1}{2} CV^2 + \frac{1}{2} CV^2 = CV^2$

Physics 212

68

Special Capacitor: Defibrillator

Q: How much energy, E_{cap} , is in the 42 μF defibrillator capacitor charged to 5 kV? $E_{cap} =$

- A. 5.25 mJ
- B. 5.25 J
- C. 525 J
- D. 525 MJ
- E. 525 GJ

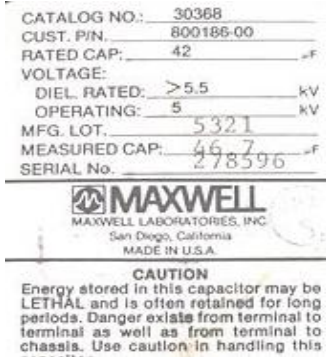

Q: Half of the capacitor's charge, Q , is then drained off. How much energy does it hold now?

- A. $\frac{E_{cap}}{8}$
- B. $\frac{E_{cap}}{4}$
- C. $\frac{E_{cap}}{2}$
- D. E_{cap}
- E. $2E_{cap}$

Batteries store and generate electrical energy with a chemical reaction

In History...

Alessandro Volta published the invention of the battery around 1790. The unit of electric "pressure", the **volt**, is named in his honor.

Unlimited electric energy... If only it could be of some use!

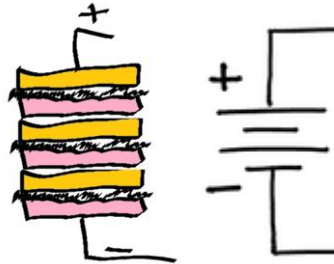

Explore More! on Batteries

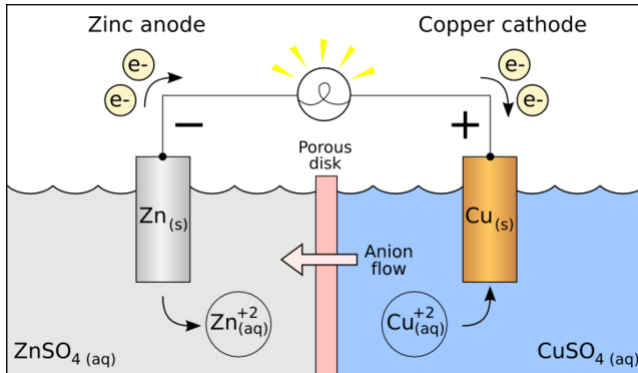

Attribution-ShareAlike 3.0 Unported
(CC BY-SA 3.0)

Image from Wikipedia, The original uploader was Ohiostandard at English Wikipedia - Transferred from en.wikipedia to Commons by Burpelson AFB using CommonsHelper., CC BY-SA 3.0, <https://commons.wikimedia.org/w/index.php?curid=11236033>

Read more:
https://en.wikipedia.org/wiki/Galvanic_cell

Chemistry 102 and 103!

71

Batteries

Q: How much charge moves through a 9-V battery to provide 3 J of energy?

- A. 0.33 C
- B. 3 C
- C. 27 C
- D. 330 MJ
- E. 27 kC

Q: If a battery is labeled at 9 V and 500 mAh, how much energy does it store in joules?

- A. 18 mJ
- B. 56 mJ
- C. 4.5 J
- D. 18 J
- E. 16 kJ

Q: For how long can such battery power an LED if that draws 50 mA of current?

- A. 0.1 hr
- B. 1 hr
- C. 5 hr
- D. 10 hr
- E. 50 hr

72

Circuit model for car window defroster

Q: What is the resistance of the car window defroster if it dissipates 60 W?
(Consider that the car battery has a max available current of 500 A)

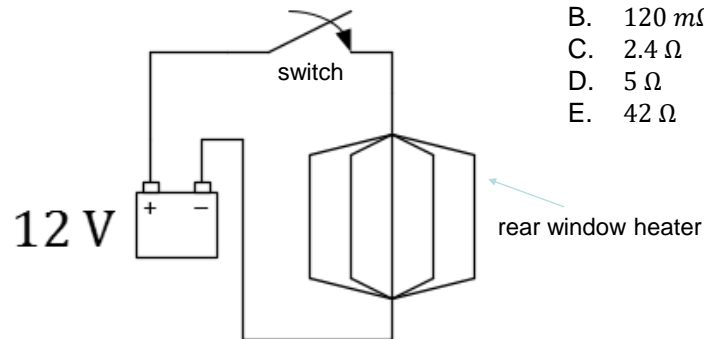

- A. 24 m Ω
- B. 120 m Ω
- C. 2.4 Ω
- D. 5 Ω
- E. 42 Ω

Q: What percentage of the available battery current is sent to the rear window heater?

- A. 1%
- B. 10%
- C. 50%
- D. 75%
- E. 95%

73

A coil with current acts as a magnet

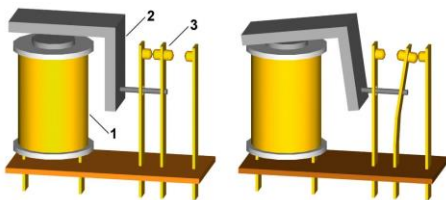

Relay principle: 1. Coil, 2. Armature, 3. Moving contact
Source: Wikimedia Commons

Q: For how long can Energizer 522 (~500 mAh) 9 V battery operate a relay (JQX-15F) which draws 100 mA?

- A. About 1.5 hours
- B. About 3 hours
- C. About 5 hours
- D. About 9 hours
- E. About 45 hours

74

The Transistor

- The transistor changed the world!
- Prior to the transistor, we had the vacuum tube:
 - Large
 - Hot
 - Low efficiency
 - High failure rate
 - Could not be integrated into an IC

75

The MOSFET (a transistor)

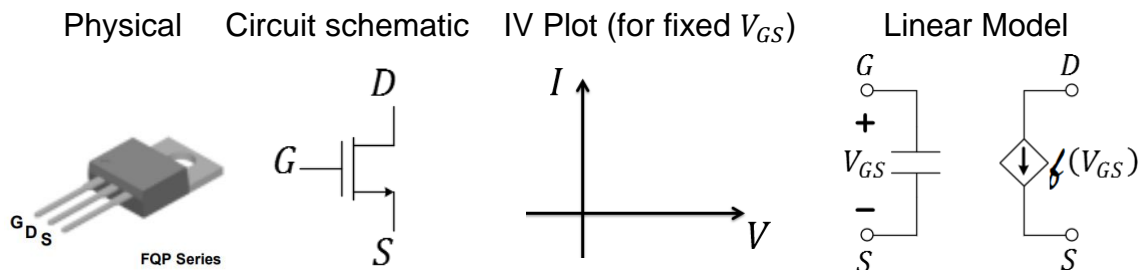

Interpretation: Terminals D and S may be considered to contain a current source whose current is controlled by V_{GS} . The controlling side is generally much lower power than the current source side making the controller easier to design and lower cost.

76

The MOSFET In Practice

In lab, we will use the MOSFET as an efficient method of motor control...

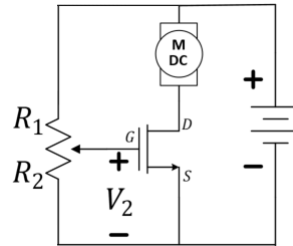

77

The (Logical) Inverter

The inverter is a *powered* IC, meaning that it will need something like a battery to make it work. In the circuit schematic, it is assumed that the voltage at input A and the output G are measured relative to the negative side of the battery, referenced as “ground” in the Linear Model.

Physical

Circuit schematic

IV Plot (for output G)

Linear Model (for G)

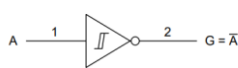
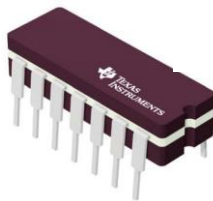

V_{DD} = Pin 14
 V_{SS} = Pin 7

Copyright © 2017, Texas Instruments Incorporated

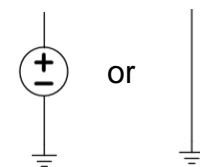
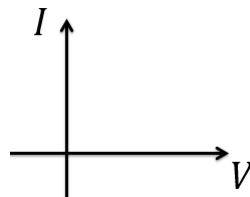

Interpretation: The output, G, of the inverter will look like either a voltage source (when the input voltage at A is low or a wire (short to ground) when the input voltage is close to the supplied battery voltage.

78

The Inverter in Practice

In lab, we use an inverter as the power source to drive an LED as ambient light is blocked from a photoresistor (by a hand or a cloud). The inverter, itself, gets power from a battery attached between pins 7 and 14. The inverter *buffers* the control circuit from the LED which the light-detection circuit is unable to power directly.

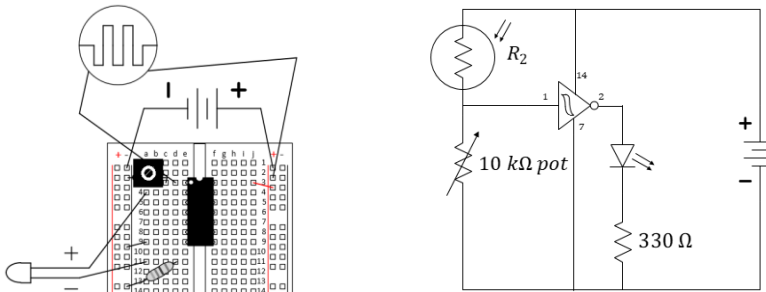

79

L5 Learning Objectives

- Compute current/voltage rating for a resistor based on its power rating
- For a capacitor, compute stored energy, voltage, charge, and capacitance given any of the two quantities.
- Compute energy stored in a battery and discharge time.
- Identify features of the Transistor that make it an improvement over vacuum tubes
- Describe the MOSFET and a simple model for it
- Describe an Inverter and a simple model for it

80



Lecture 6: Kirchhoff's Laws in Circuits

- Kirchhoff's Current Law (KCL) – Conservation of Charge
- Kirchhoff's Voltage Law (KVL) – Conservation of Energy
- Solving Circuits with KCL, KVL, and Ohm's Law
- Power Conservation in Circuits

81



Kirchhoff's Current Law

Current in = Current out

Conservation of charge!

(What goes in must come out, or...
...the total coming in is zero)

Through a closed surface (balloon), $\sum_{k=1}^N I_k = 0$ where I_k are the currents flowing in (alt. out) of the balloon.

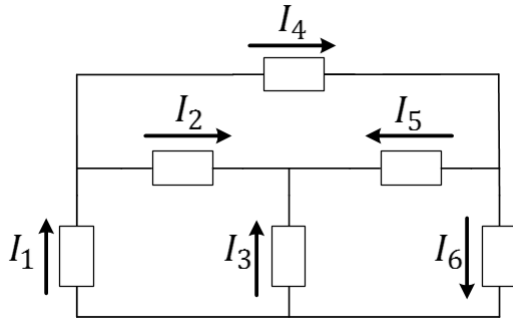

Image source: MONGABAY.COM

82



KCL equations are often used at *nodes*, but can also be used for a *sub-circuit*



Q: Which of the equations is NOT a correct application of KCL?

- A. $I_1 = I_2 + I_4$
- B. $I_4 = I_5 + I_6$
- C. $I_1 + I_3 = I_6$
- D. $I_3 + I_5 = I_2$
- E. $I_6 - I_4 = I_3 + I_2$

83



Kirchhoff's Voltage Law

The sum of all voltages around any closed path (loop) in a circuit equals zero

Conservation of Energy!

With voltage, what goes up, must come down

Around a closed loop (path) $\sum_{k=1}^M V_k = 0$ where V_k are the voltages measured CW (alt. CCW) in the loop.

84

KVL and Elevation Analogy



Winter mountaineering in the German/Austrian Alps. Photo: Bernd Eberle.

Picture: <https://www.explore-share.com/blog/what-is-mountaineering/>

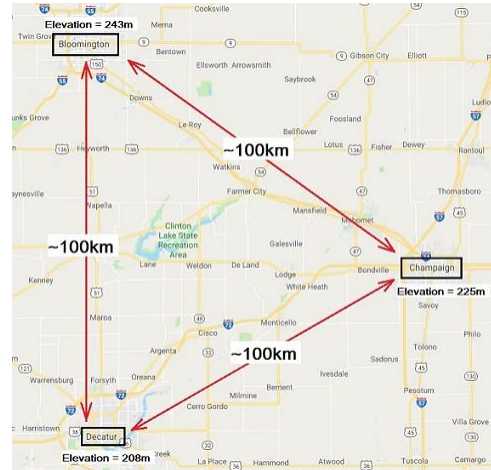

One can add up elevation changes as we go in a complete loop from city to city. The result should be zero, independent of the path taken.

85

Keeping track of voltage drop *polarity* is important in writing correct KVL equations.

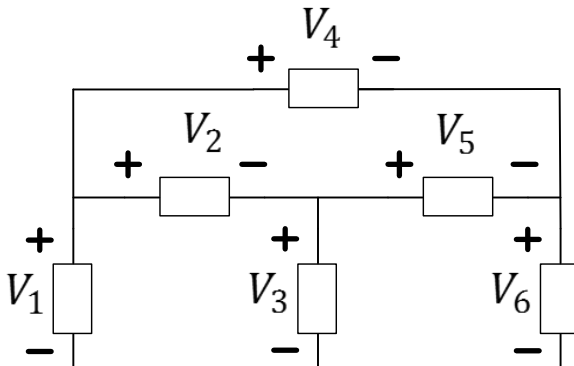

Q: Which of the equations is NOT a correct application of KVL?

- A. $V_1 - V_2 - V_3 = 0$
- B. $V_1 = V_2 + V_5 + V_6$
- C. $V_1 - V_4 = V_6$
- D. $V_3 + V_2 = V_1$
- E. $V_3 + V_5 = V_6$

86



Missing voltages can be obtained using KVL.

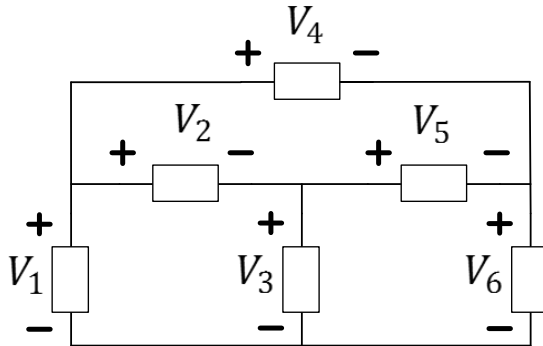

In History...

The conceptual theories of electricity held by **Georg Ohm** were generalized in **Gustav Kirchhoff's** laws (1845). Later, **James Clerk Maxwell's** equations (1861) generalized the work done by Kirchhoff, Ampere, Faraday, and others.

Explore More!

$$\oiint_{\partial\Omega} \mathbf{E} \cdot d\mathbf{S} = \frac{1}{\epsilon_0} \iiint_{\Omega} \rho dV$$

$$\oiint_{\partial\Omega} \mathbf{B} \cdot d\mathbf{S} = 0$$

$$\oint_{\partial\Sigma} \mathbf{E} \cdot d\boldsymbol{\ell} = -\frac{d}{dt} \iint_{\Sigma} \mathbf{B} \cdot d\mathbf{S}$$

$$\oint_{\partial\Sigma} \mathbf{B} \cdot d\boldsymbol{\ell} = \mu_0 \iint_{\Sigma} \mathbf{J} \cdot d\mathbf{S} + \mu_0 \epsilon_0 \frac{d}{dt} \iint_{\Sigma} \mathbf{E} \cdot d\mathbf{S}$$

Maxwell's equations in Integral Form
Image Credit: Wikipedia.org

ECE 329 Fields and Waves I

Q: What are the values of the voltages V_1 , V_2 and V_6 if $V_3 = 2\text{ V}$, $V_4 = 6\text{ V}$, $V_5 = 1\text{ V}$?

87



Examples

Q: Find the value of I .

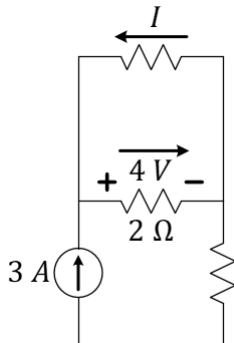

- A. -3 A
- B. -2 A
- C. -1 A
- D. 1 A
- E. 2 A

Q: Find the value of V .

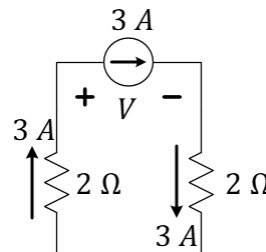

- A. -12 V
- B. -6 V
- C. -3 V
- D. 6 V
- E. 12 V

88



Circuits solved with Ohm's + KCL + KVL

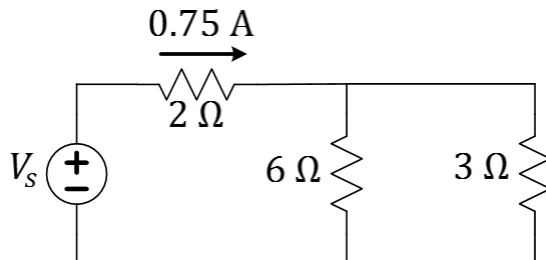

Q: What is the value of the source voltage?

Q: How much power is the source supplying?

Q: How much power is each resistance consuming?

89



L6 Learning Objectives

- Identify and label circuit nodes; identify circuit loops
- Write node equation for currents based on KCL
- Write loop equations for voltages based on KVL
- Solve simple circuits with KCL, KVL, and Ohm's Law
- Calculate power in circuit elements, verify conservation

90



Lecture 7: Circuit Tools

- Equivalent Resistance Defined
- Voltage Divider
- Current Divider
- Power Dissipation in Series and Parallel Resistive Loads
- Example Problems and Practice

91



Series Connection

Series connections share the same current

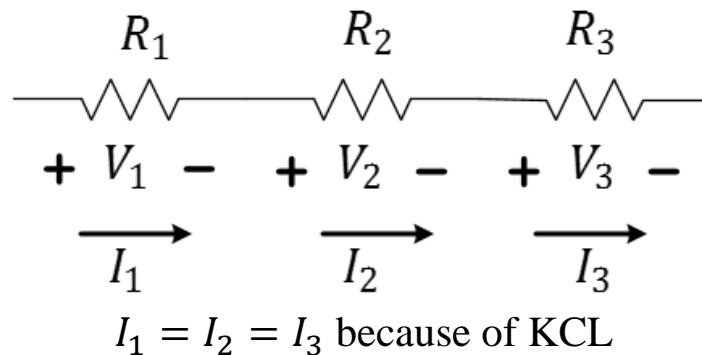

92

Equivalent Resistance

Equivalent Resistance is the resistance value you get when you place an entire resistive network into a (virtual) box and characterize it as an Ohmic device (a new resistor).

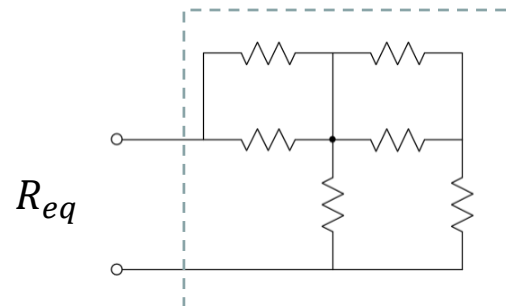

93

Equivalent Resistance of Series Resistors

Resistances in series add up

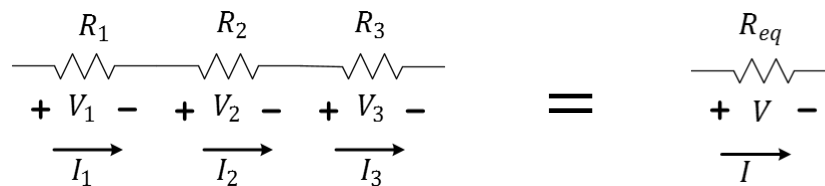

$$R_{eq} = R_1 + R_2 + \dots + R_N$$

This can be intuitive: think of telegraphy wires in series.

94

Voltage Divider Rule (VDR)

When a voltage divides across resistors in series, more voltage drop appears across the largest resistor.

$$V_k = \frac{R_k}{R_{eq}} \cdot V_T$$

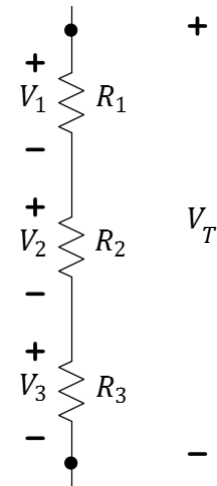
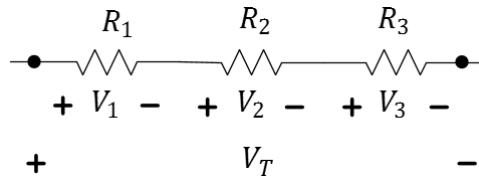

Q: Can V_1 be a larger value than V_T ?

- A. Yes
- B. No
- C. Not sure

95

Q: If $R_1 < R_2$, which of the following is true?

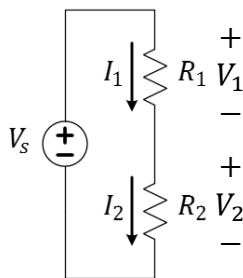

- A. $V_1 < V_2$ and $I_1 < I_2$
- B. $V_1 < V_2$ and $I_1 = I_2$
- C. $V_1 = V_2$ and $I_1 = I_2$
- D. $V_1 > V_2$ and $I_1 = I_2$
- E. $V_1 > V_2$ and $I_1 > I_2$

Q: Use VDR to find V_1 .

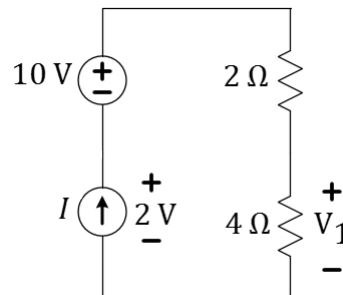

- A. $V_1 \leq -6V$
- B. $-6 < V_1 \leq -2V$
- C. $-2 < V_1 \leq 2V$
- D. $2 < V_1 \leq 6V$
- E. $6V < V_1$

96

VDR Derivation

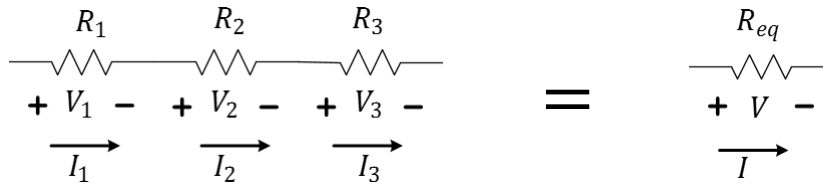

Since $I = I_k$, $\frac{V}{R_{eq}} = \frac{V_k}{R_k}$ by Ohm's Law. So, $V_k = \frac{R_k}{R_{eq}} \cdot V$

97

One VDR Application

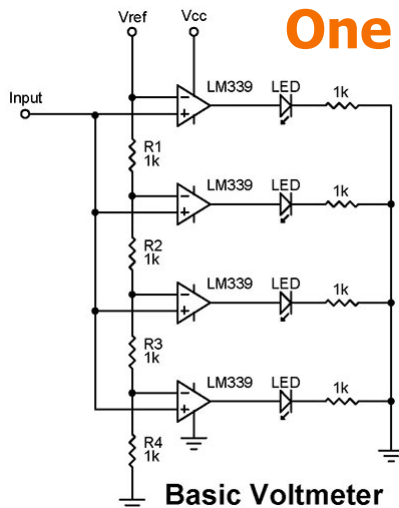
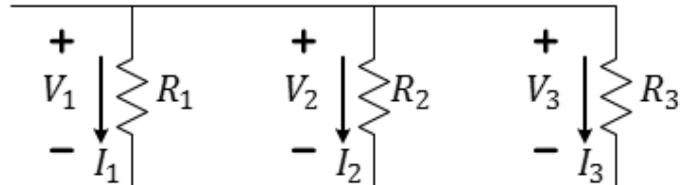

Image from <https://www.nutsvolts.com/questions-and-answers/led-voltmeter>

98

Parallel Connection

Parallel connections share the same voltage potentials at two end nodes (shared by the elements)



$$V_1 = V_2 = V_3 \text{ because of KVL}$$

Q: Are appliances in your house/apartment connected in series or in parallel? A. B.

99

Equivalent Resistance of Parallel Resistors

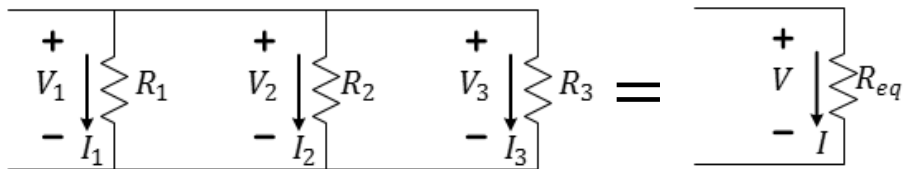

$$\frac{1}{R_{eq}} = \frac{1}{R_1} + \frac{1}{R_2} + \dots + \frac{1}{R_N}$$

$$\text{If } N = 2, \quad R_{eq} = \frac{R_1 R_2}{R_1 + R_2}$$

Q: Which statement is true in general?

- A. $R_{eq} \approx R_1$
- B. $R_{eq} < R_1$
- C. $R_{eq} > R_1$
- D. None of these is true

100

Resistors

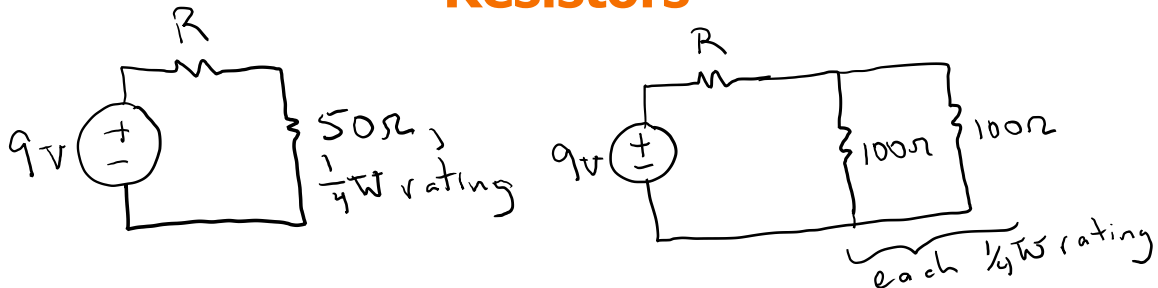

Q: Which statement is true regarding a single 50-Ohm resistor and two 100-Ohm resistors used as shown above in the same circuit?

- A. The 100-Ohm parallel combination has twice the power rating.
- B. The 100-Ohm parallel combination has a resistance of 200 Ohms.
- C. The 100-Ohm parallel combination has twice the probability of failure.
- D. None of these are true.
- E. All of these are true.

101

Current Divider Rule (CDR)

When a current divides into two or more paths, a greater amount of current will go down the path of lower resistance.

$$I_k = \frac{R_{eq}}{R_k} \cdot I$$

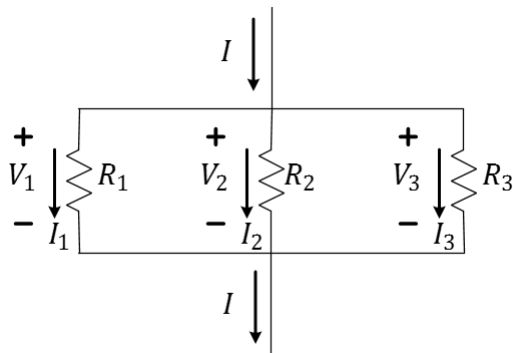

102

One CDR Application

- High-current Ammeter
- Use a high-power shunt resistance R_S to carry most of the current
- Measure the current through R_M (the meter resistor) using a galvanometer.

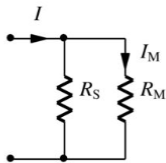

Q: Which is true in this application?

- $R_S \ll R_M$
- $R_S \gg R_M$
- $R_S \approx R_M$

Q: Give the formula for I (the current we want measured) in terms of I_M (the current we did measure).

103

Q: If $R_1 < R_2$, which of the following is true?

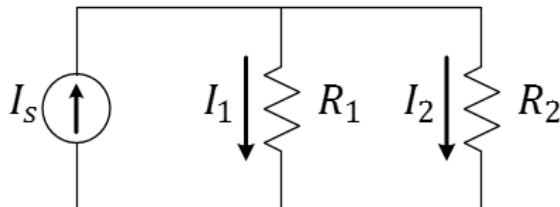

- $I_1 < I_2 < I_S$
- $I_1 < I_S < I_2$
- $I_2 < I_1 < I_S$
- $I_2 < I_S < I_1$
- $I_S < I_2 < I_1$

A.

B.

Q: In a parallel connection, does a smaller or larger resistor absorb more power?

104

VDR and CDR for Two Resistances

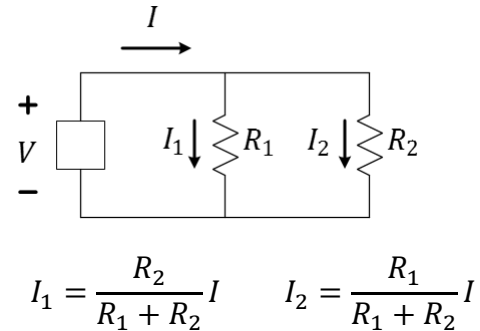
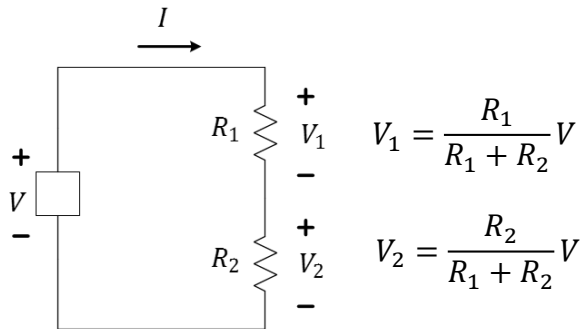

Bad Idea: try to **memorize** these formulae.

Good Idea: try to note trends and **understand concepts** !

Example, if $R_1 = 1\ \Omega$ and $R_2 = 2\ \Omega$, then $V_2:V_1$ will be in a 2:1 ratio for the series circuit.

If $R_1 = 1\ \Omega$ and $R_2 = 2\ \Omega$, then $I_2:I_1$ will be in a 1:2 ratio for the series circuit.

Why?

105

VDR and CDR for Two Resistances

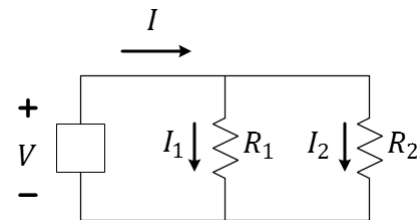
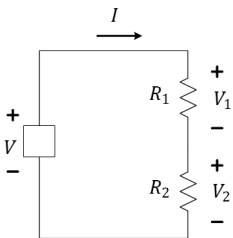

Q: If 6V falls across a series combination of $1\text{k}\Omega$ and $2\text{k}\Omega$, what is V across $2\text{k}\Omega$?

Q: If 0.15A flows through a parallel combo of $1\text{k}\Omega$ and $2\text{k}\Omega$, what is I through $2\text{k}\Omega$?

106

VDR and CDR for Two Resistances

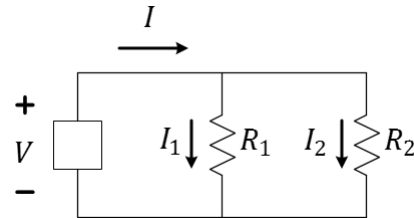
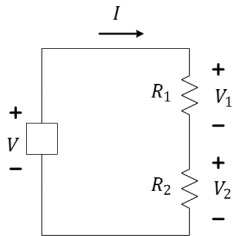

Q: If a source supplies 60W to a series combination of 10Ω and 30Ω , what is the power absorbed by the 10Ω resistor? What power is absorbed by the 30Ω resistor?

Q: If a source supplies 300mW to a parallel combination of $3k\Omega$ and $2k\Omega$, what is the power absorbed by the $3k\Omega$ resistor? What power is absorbed by the $2k\Omega$ resistor?

107

L7 Learning objectives

- Identify series and parallel connections within a circuit network
- Compute power ratings of resistor networks
- Find equivalent resistance of circuit networks
- Estimate resistance by considering the dominant elements
- Apply rules for current and voltage division to these networks
- Apply conservation of energy to components within a circuit network

108



Lecture 8: Application of Circuit Laws

- Example Problems and Practice

109



Circuits solved with Ohm's + KCL + KVL

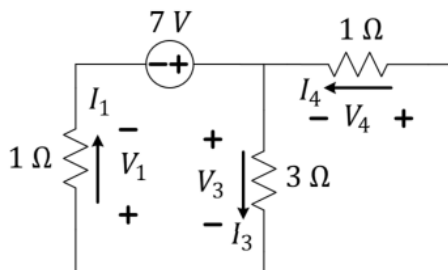

Find the value of the current I_3 .

110



Circuits solved with Ohm's + KCL + KVL

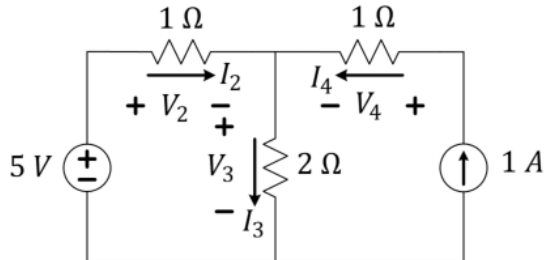

Find the value of the current I_3 .

111



Grading policies

A+	Greater than 97%
A	93-97%
A-	90-93%
B+	87-90%
B	83-87%
B-	80-83%
C+	77-80%
C	73-77%
C-	70-73%
D+	67-70%
D	63-67%
D-	60-63%
F	Less than 60%

Laboratory	30% ¹
Lecture Total	70% ¹
3 midterms	30%
Final Exam	25% ²
Homework	10%
Attendance	5%

¹You must obtain 50% of the lecture score and 50% of the lab score to avoid failing the course!

²The Final Exam can have an effective weight of 35% by replacing the lowest midterm grade.

112



Seeking advice and help?

- **Talk to us!** Instructors, graduate TAs, undergrad course aides want to know you!
- **CARE:** the *Center for Academic Resources in Engineering* provides study periods and tutoring options in many STEM courses.
- **ECE Advising Office** (2120 ECEB) provides all kinds of advice. They can also recommend others:
 - **U of I Counseling Center** for time management, study skill, test-taking skills, and confidential personal counseling. Plus, Dr. Ken at Engineering Hall!
 - **DRES:** the Disability Resources & Educational Services center for aid in overcoming unique challenges that you may encounter through your education

113



Learning Objectives

- Example Problems and Practice
- Series and Parallel resistance
- Equivalent Resistance
- More Problems and Practice

114

Lecture 9: AC and Time-average Power

- AC and DC
- Time-average Powre
- Root-Means-Square (RMS) Voltage
- The Meaning of Current and Voltage Sources
- Labeling of Current and Voltage and Sign of Power

115

Alternating vs. Direct Current

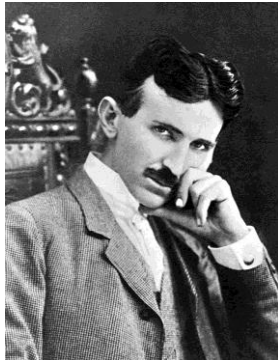

Nikola Tesla

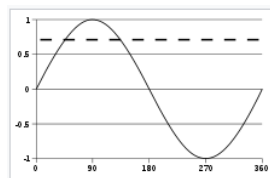

A sine wave, over one cycle (360°).
The dashed line represents the **root mean square (RMS)** value at about 0.707

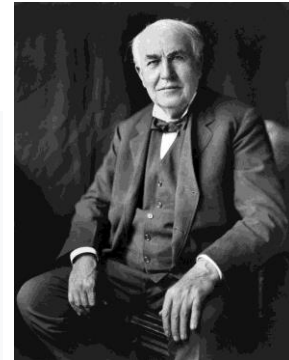
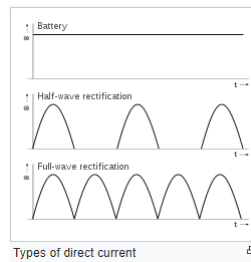

Thomas A. Edison

Have you ever heard of the “Current Wars”?

- A. Yes
- B. No

116

In Practice: Time-varying signals

In lab, we use the output of the inverter to change the input in a feedback loop. A "high" output drives the input high and a low input drives the input low. The inverter's function causes "oscillation" to occur and the LED to flash. Note how the capacitor allows for changing input voltage.

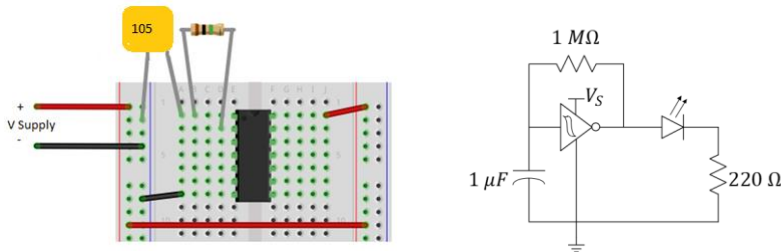

117

Power

For time-varying signals, power is a time-varying signal.

$$p(t) = i(t)v(t)$$

The time-average power is often of interest. Time average is computed by the equation

$$P_{avg} = \frac{\int_{-\infty}^{\infty} p(t) dt}{\int_{-\infty}^{\infty} dt}$$

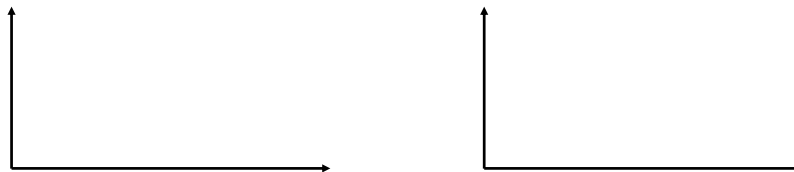

118

Power

$$P_{avg} = \frac{\int_{-\infty}^{\infty} p(t) dt}{\int_{-\infty}^{\infty} dt}$$

- If $v(t)$ and $i(t)$ are periodic, then $p(t)$ is periodic with period T

$$P_{avg} = \frac{\int_T p(t) dt}{T} = \text{area under } p(t) \text{ divided by } T = \text{Energy in one period divided by } T$$

- If $v(t)$ and $i(t)$ are constant (DC), then $p(t)$ is constant

$$P_{avg} \equiv P = IV$$

For non-periodic signals (e.g. constant white noise)

$$P_{avg} \approx \frac{\int_T p(t) dt}{T}$$

Where T is a sufficiently-long observation time

119

Voltage from the wall plug is *sinusoidal*

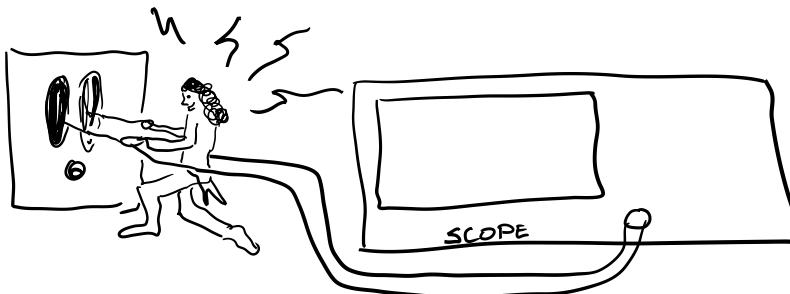

Q: What is the peak instantaneous power absorbed by a 250Ω light bulb?

- 1 W
- 10 W
- 100 W
- 1 kW
- 10 kW

In History...

In the 1880's and 1890's, **Nikola Tesla** played a large role in improving DC motors, developing AC motors and generators, and developing many high-frequency/high-voltage experiments including many in the area of remote control and wireless telephony. **Marconi's** 1901 cross-Atlantic wireless transmission likely infringed upon a few of Tesla's nearly 300 patents.

120



Time Average Power: What's RMS??

$$\begin{aligned}
 P_{avg} &= \frac{\int_{-\infty}^{\infty} p(t) dt}{\int_{-\infty}^{\infty} dt} \\
 &= \frac{\int_{-\infty}^{\infty} v(t)i(t) dt}{\int_{-\infty}^{\infty} dt} \\
 &= \frac{\int_{-\infty}^{\infty} \frac{v^2(t)}{R} dt}{\int_{-\infty}^{\infty} dt} \quad (\text{for a resistor}) \\
 &= \frac{1}{R} \frac{\int_{-\infty}^{\infty} v^2(t) dt}{\int_{-\infty}^{\infty} dt} \\
 &= \frac{1}{R} \text{avg}\{v^2(t)\}
 \end{aligned}$$

Define $V_{rms} \stackrel{\text{def}}{=} \sqrt{\frac{\int_{-\infty}^{\infty} v^2(t) dt}{\int_{-\infty}^{\infty} dt}}$ so that $P_{avg} = \frac{V_{rms}^2}{R}$
(for a resistor)

Important Comment: RMS voltage helps us find time-averaged power. We don't want RMS power...what does that even mean??

Important Comment #2: for things that are not resistors, we may need to look at $p(t)$ directly as V_{rms} doesn't tell the whole story.

Important Comment #3: You can use both V_{rms} , I_{rms} , and something called a power factor in more-advanced circuit courses. Eg. ECE342

121



Root-Mean-Square averages

RMS is meaningful when interested in power production/dissipation in AC.

$$V_{RMS} = \sqrt{\text{Average}[v^2(t)]}$$

1. Sketch $v^2(t)$
2. Compute $\text{Average}[v^2(t)]$
3. Take $\sqrt{\quad}$ of the value found in part 2.

122



Calculating P_{avg} and V_{rms}

Trig identity: $\cos(\alpha) \cos(\beta) = \frac{1}{2} [\cos(\alpha - \beta) + \cos(\alpha + \beta)]$

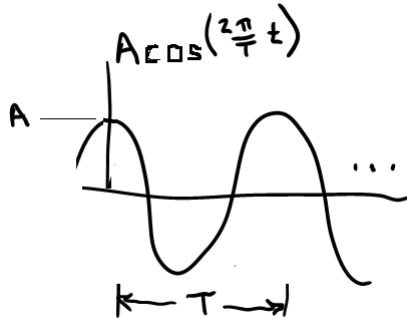

USA "Mains voltage"

Q: What is the average power absorbed by a 250Ω light bulb if $A = 170V$?

123



Calculating P_{avg} and V_{rms}

Duty Cycle Definition: $\frac{T_{ON}}{T}$

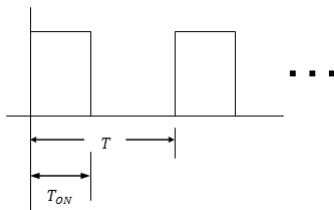

Q: What happens to power and V_{rms} when T_{ON} is halved while T is unchanged?

124



Calculating P_{avg} and V_{rms}

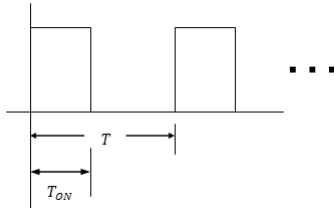

Q: Why isn't the RMS voltage of the signal above generally equal to $V_{rms}/\sqrt{2}$?

125



L9 Learning Objectives

- Compute the time-average power from $p(t)$ plots
- Compute the rms voltage from $v(t)$ plots
- Explain the meaning of V_{rms} and relationship to P_{avg}

126



Lecture 10: Signed Power and Design

- Exercises under constraints on components

127



Which of the sources are delivering power?

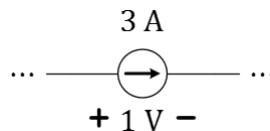
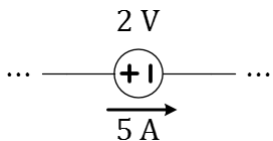

- The voltage source only
- The current source only
- Both
- Neither
- Not enough information to tell

128



Polarity labels for Kirchhoff are Arbitrary

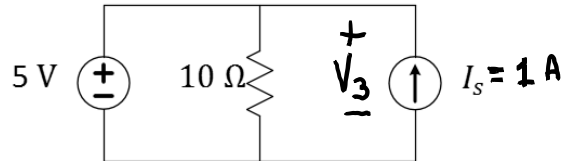

Q: Find the value of V_3 .

Q: Find the power, P_3 .

129



Polarity labels for Kirchhoff are Arbitrary

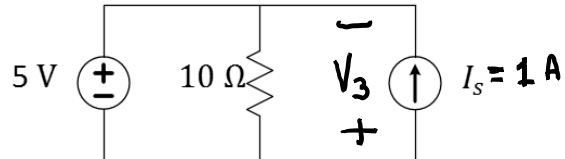

Q: Find the value of V_3 .

Q: Find the power, P_3 .

Q: Does the sign of P_3 have any meaning?

130



Polarity Labels for Power MATTERS!

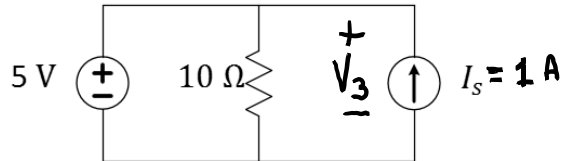

Standard convention means to assign current arrow as flowing from voltage's + to – labels. Alternately, you assign voltages + and – labels at the tail and point of the current arrow, respectively.

Although you can use ANY polarity labels to apply KVL and KCL...

- Use Standard (also called “passive”) convention if computing power
- Use Standard convention if applying Ohm’s Law

131



Ohm’s Law: $V=IR$ Assumes Standard Convention

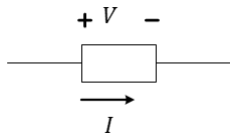

“Current downhill” is preferable for resistors

If a resistor, then...

$$V = IR$$

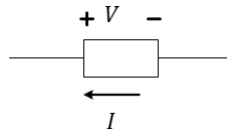

“Current uphill” can be convenient for sources.

$$V = -IR$$

Universal Ohm’s Law:

$$I_{+ \rightarrow -} = \frac{V}{R}$$

132

Power Equation: $P=IV$ Assumes Standard

Using the standard polarity labeling: $P = V I_{+ \rightarrow -}$

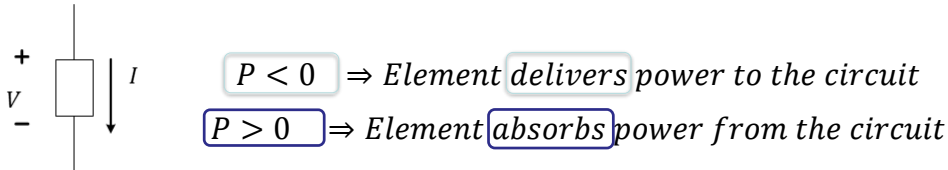

133

Recap of labeling implication

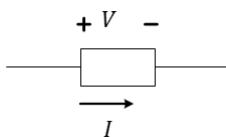

$$R = \frac{V}{I}$$

$$P = VI$$

“Standard Reference”

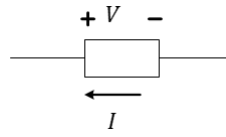

$$R = -\frac{V}{I}$$

$$P = -VI$$

“Non-Standard Reference”

This way, power is defined such that it is negative when it is supplied (sourced) and positive when it is absorbed (sunk).

Universal:

Ohm's Law: $I_{+ \rightarrow -} = \frac{V}{R}$
 Power Eqn: $P = VI_{+ \rightarrow -}$

L7Q6: With power defined as above, what is the sum of powers for all circuit elements?

134



Which of the sources below absorbs power?

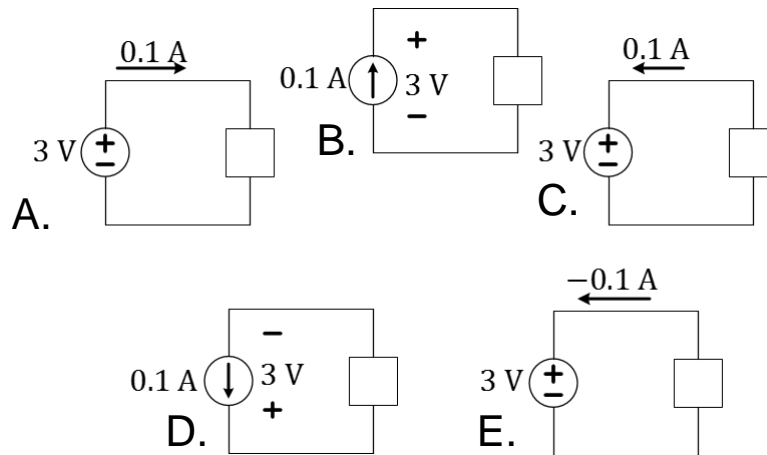

135



Either or Both Sources Can Supply Power

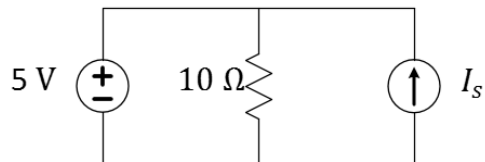

Q: For what values of I_s do both sources supply power?

Q: For what values of I_s does only the current source supply power?

Q: For what values of I_s does only the voltage source supply power?

136



Exercise

Q: What is the maximum value of I_s for which the voltage source supplies power?

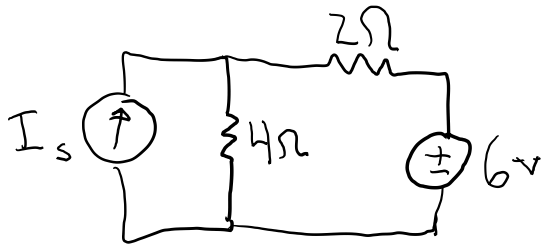

- A. -3 A
- B. -1.5 A
- C. 0 A
- D. 1.5 A
- E. 3 A

137



L10 Learning Objectives

- a. Assign polarity of current and voltage
- b. Properly apply Ohm's Law to conditions of standard and non-standard polarities
- c. Properly apply the signed-Power formula to to conditions of standard and non-standard polarities
- d. Derive solutions of circuits under specific power constraints.

138



Lecture 11: IV Characteristics

- Measuring I-V Characteristics of Circuits
- Calculating I-V Characteristics of Linear Circuits
- Operating (I,V) point when Sub-circuits are Connected
- Power and the I-V Characteristics

139



What's in the Box?



140

Measuring IV Data

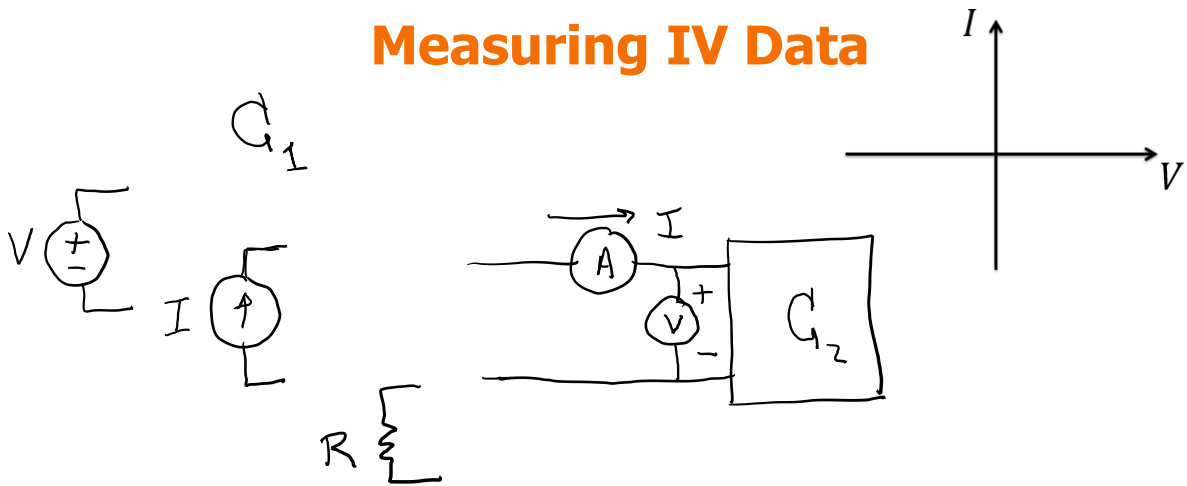

Q: What is the voltage drop across an ideal current-meter (ammeter)?

141

Measuring IV Data

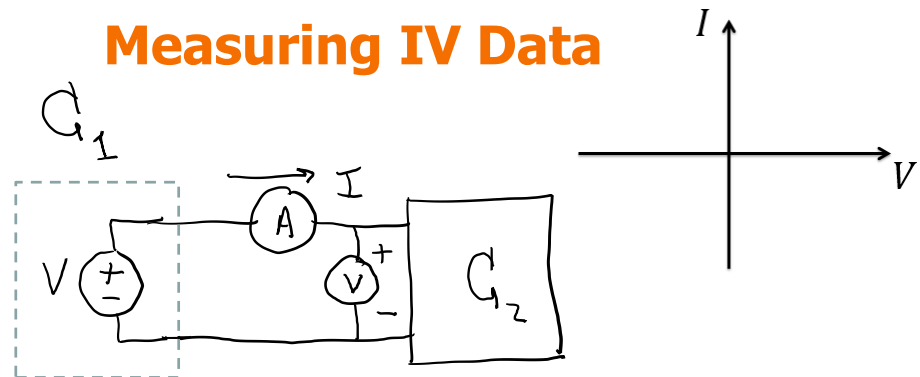

Q: What is the voltage drop across an ideal current-meter (ammeter)?

- A. 0 V
- B. 1 V
- C. Depends on the ammeter's internal resistance

142

Measuring IV Data

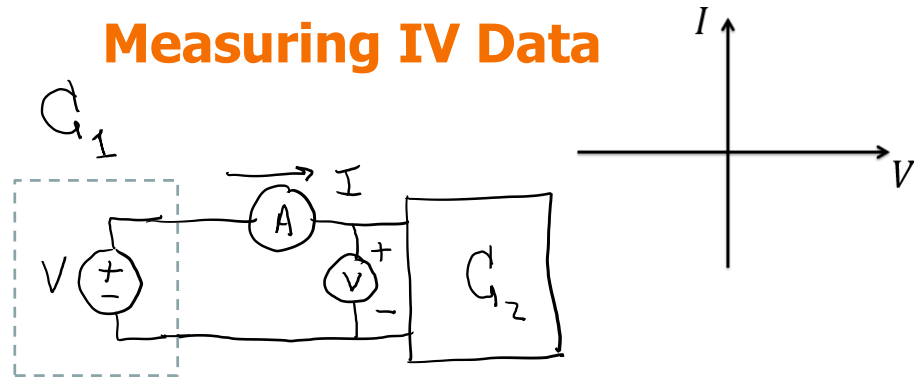

Q: When would this technique be a bad idea?

- A. When C_2 is another voltage source
- B. When C_2 is a current source
- C. When C_2 is a resistor

143

Measuring IV Data

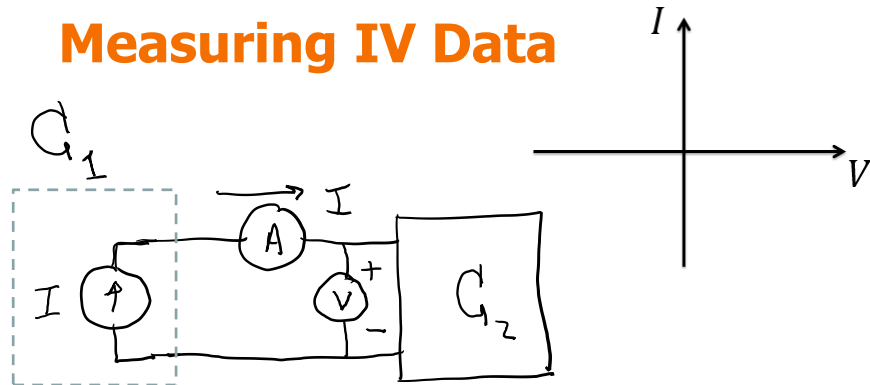

Q: What is the current flow through an ideal voltmeter?

- A. 0 A
- B. 1 A
- C. Depends on the voltmeter's internal resistance

144

Measuring IV Data

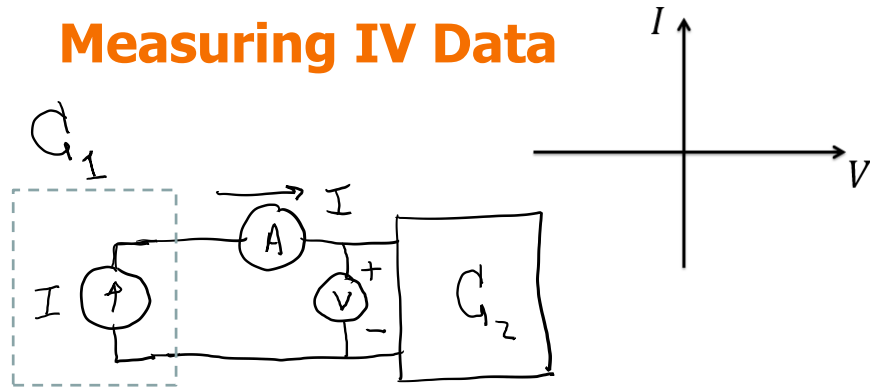

Q: When would this technique be a bad idea?

- A. When C_2 is another voltage source
- B. When C_2 is a current source
- C. When C_2 is a resistor

145

Measuring IV Data

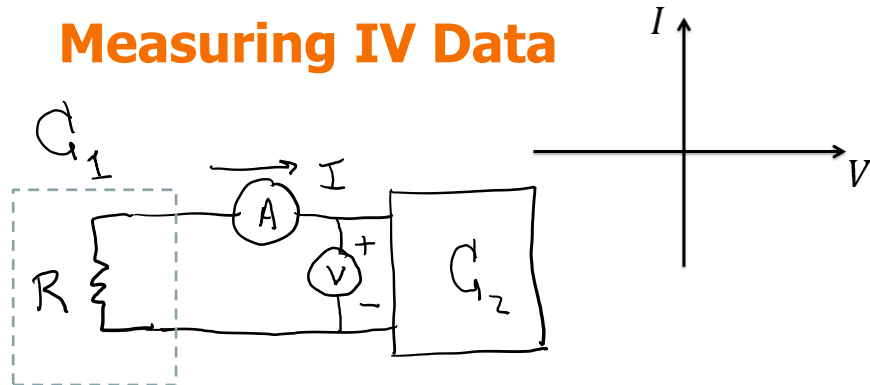

Q: When would this technique fail?

- A. When C_2 is another voltage source
- B. When C_2 is a current source
- C. When C_2 is a resistor network

146

Measuring IV Data

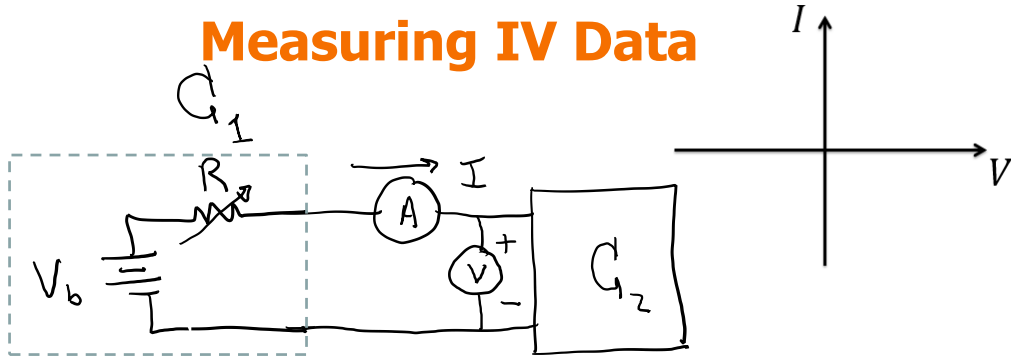

Q: Would this work? A. Yes
B. No

147

Linear I-V curves

Q: Which set of graphs corresponds to pure resistances?

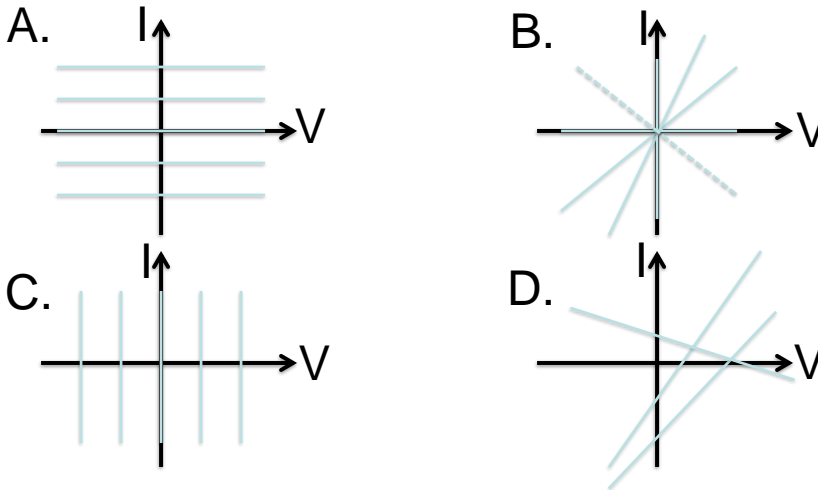

148

Simple Series Circuit

Show that the circuit has a linear IV characteristic.

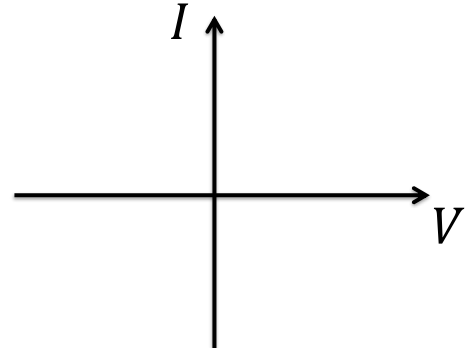
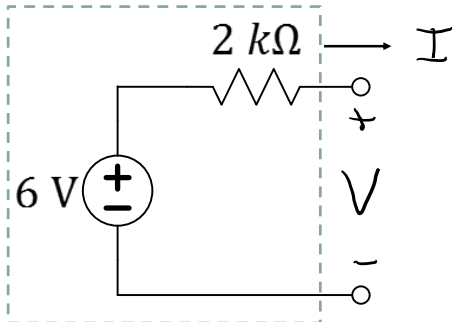

Q: Find m and b such that $I = mV + b$ and then graph it.

149

Embedded Voltage Source

Show that this circuit also has a linear IV characteristic.

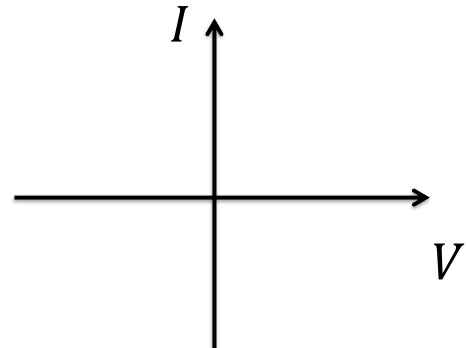
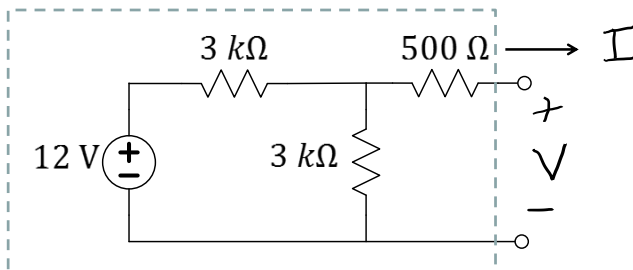

Q: Find m and b such that $I = mV + b$ and then graph it.

150

Embedded Voltage Source

Show that this circuit also has a linear IV characteristic.

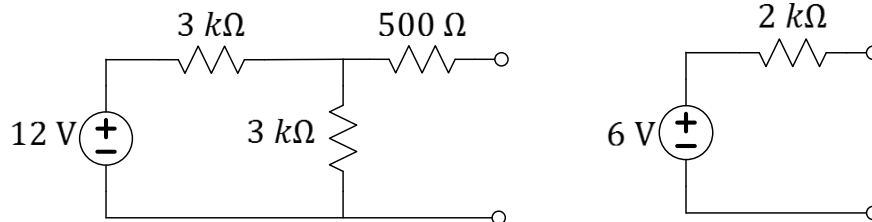

Q: If both circuits produce the same $I = mV + b$ plot, can the IV data be used to tell which of the two circuits is “in the box”?

- A. Yes
- B. No
- C. Other

151

Why we care

- Allows easy calculation of I and V when two sub-circuits are connected together
- Allows creating a simpler model of a given sub-circuit
- Helps understand nonlinear devices

Many Common Methods to find IV lines

- Use **circuit analysis** for *variable* V (like before)
- Find two points (usually **open** and **short**)
- Use R_{eff} and either **open** or **short** (Wednesday)

152

Linear I-Vs of source-resistor circuits

Any combination of current or voltage sources with resistor networks has a linear I-V (between any two nodes).

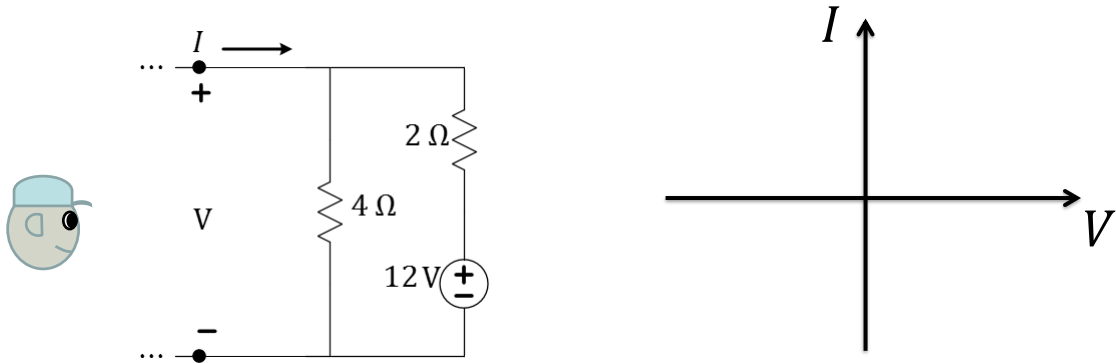

Q: What are the current values of I when V is equal to 0V, 2V, and 4V?

153

Connecting two sub-circuits

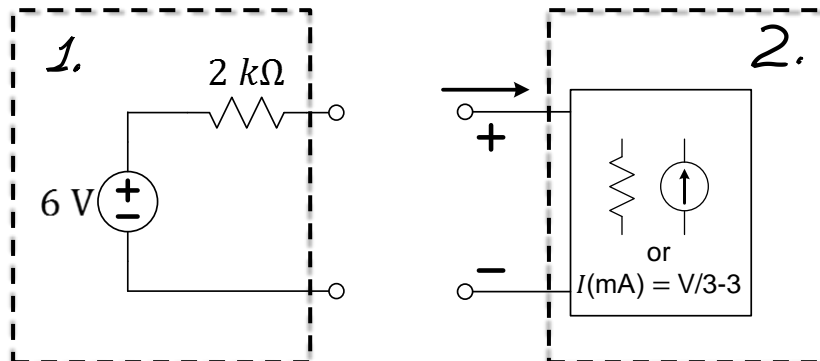

154

Connecting two sub-circuits

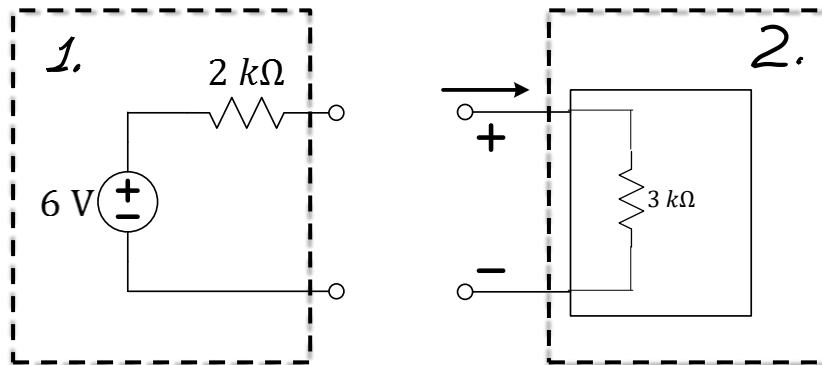

Q: What are the IV characteristics of a $3\text{ k}\Omega$ resistor?

155

Connecting two sub-circuits

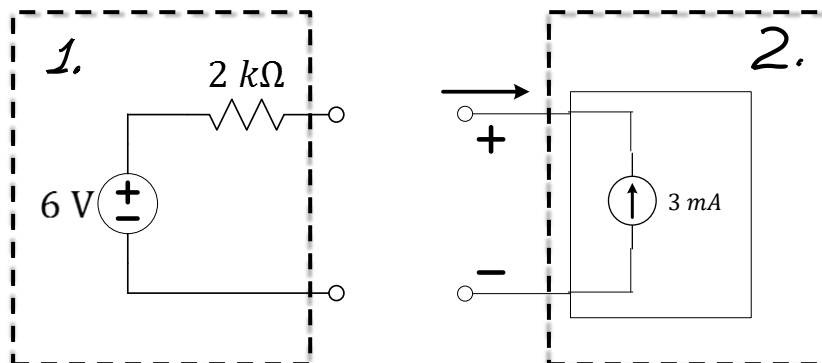

Q: What are the IV characteristics of a 3 mA current source?

156

Connecting two sub-circuits

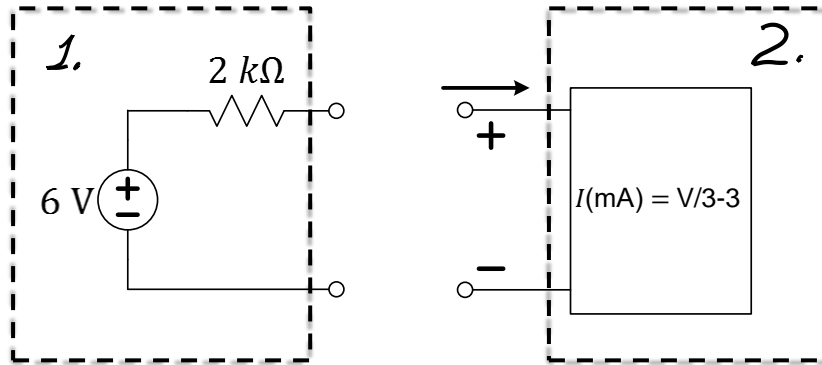

157

Connecting two sub-circuits (cont'd)

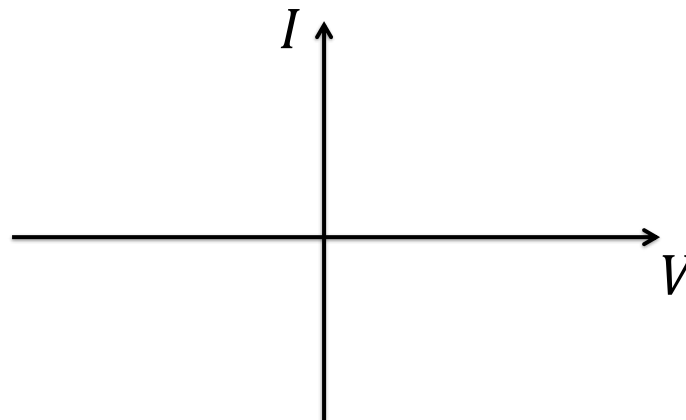

Q: Considering the three choices for circuit #2, what is the operating point when the two sub-circuits are connected? Which sub-circuit supplies the power?

158



L11 Learning Objectives

- a. Given one of the three sub-circuit descriptions (IV equation, IV line, diagram), find the other two

Note that more than one circuit diagram fits an IV description

- b. Quickly identify the IV representations of voltage and current sources, resistors, and combinations
- c. Find (V,I) operating points of connected sub-circuits
- d. Calculate power flow between connected sub-circuits

Lecture 12: Thevenin Equivalents

- Review of I-V Linear Equation
- Thevenin Equivalent Circuit
- Effective Resistance in Linear network
- Calculating R_{eff} by Removing Sources
- Problem Strategy and Practice

161

Relating I-V Line to Equation

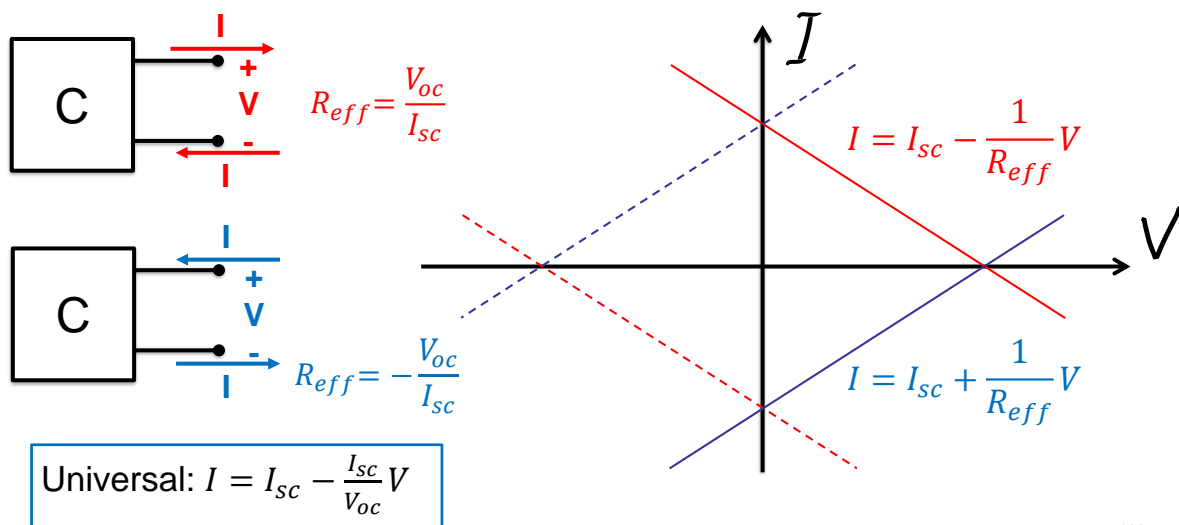

162



Thevenin Equivalent

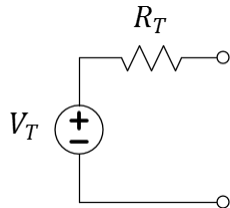

Any linear IV $I = mV + b$ can be matched by the circuit on the left with proper selection of V_T and R_T .

- The Thevenin will have the same universal formula $I = I_{sc} - \frac{I_{sc}}{V_{oc}} V$
- It will contain all information on how original circuit interact with others
- However, it loses information on power dissipation WITHIN the circuit

163



Example

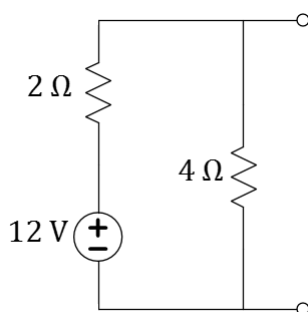

Q: Discuss different ways can you find $I = mV + b$ for this circuit.

Q: What is the Thevenin equivalent of the circuit?

164



Effective Resistance:

$R_{\text{eff}} = R_T = R_N$ is R_{eq} with sources "zeroed"

1. Short-circuit all voltage sources (i.e. set them to zero)
2. Open-circuit all current sources (i.e. set them to zero)
3. Find resulting R_{eq} using parallel and series relationships

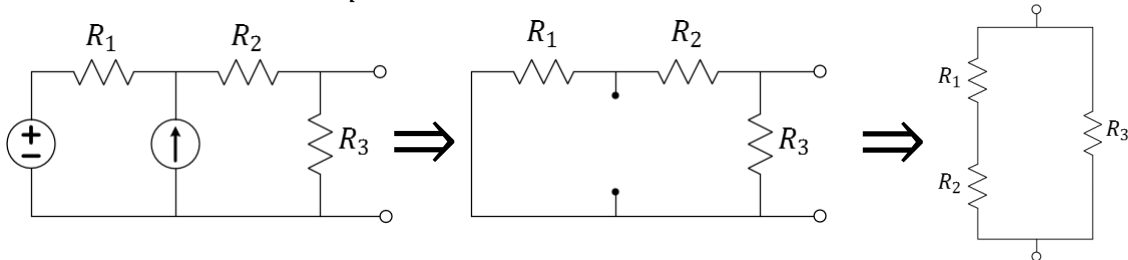

Q: How is R_{eff} related to the slope of the I-V line?

165



Finding R_{eff} is easy in multi-source circuits

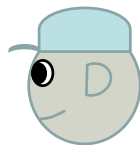
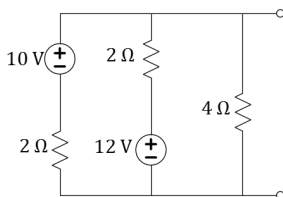

Q: What is R_{eff} , for the circuit?

- A. 8Ω
- B. 5Ω
- C. 4Ω
- D. 2Ω
- E. 0.8Ω

Q: Besides R_{eff} , is it easier to find I_{sc} or V_{oc} ?

- A. I_{sc}
- B. V_{oc}

166

One can find a circuit given a line

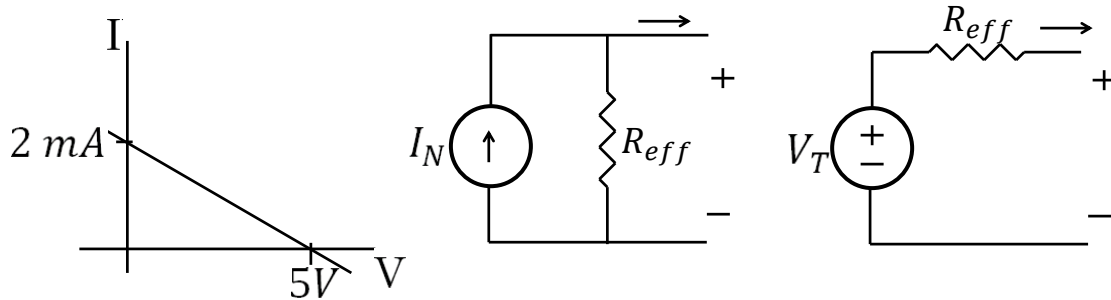

- Q: What is R_{eff} , for the circuit with the given I-V line?
- A. $2.5 \text{ m}\Omega$
 - B. $4 \text{ m}\Omega$
 - C. $4 \text{ }\Omega$
 - D. $2.5 \text{ k}\Omega$
 - E. $4 \text{ k}\Omega$

167

Practice makes perfect!

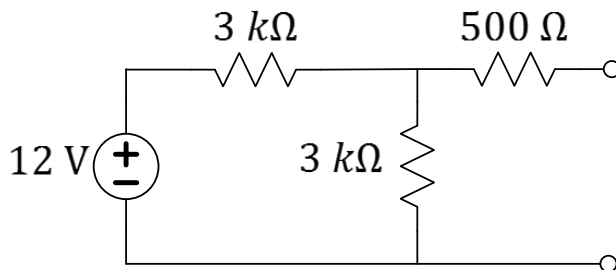

- Q: What is the Thevenin equivalent for the circuit above?

In History...

Leon Charles Thevenin was a telegraph engineer. In 1883, his theorem expanded modelling of circuits and simplified circuit analysis based on Ohm's Law and Kirchhoff's Laws.

The dual "Norton's theorem" didn't arrive until 1926 with the efforts of Bell Labs engineer, **Edward Lawry Norton**.

168



Flashback! Use Thevenin to solve.

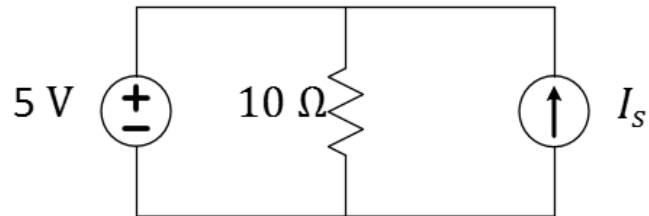

Q: For what values of I_s does only the voltage source supply power?

169



170



Summary

- Any linear network can be represented by a simple series Thévenin circuit [or, equivalently, by a simple parallel Norton circuit]
- There are several methods for determining the quantities and depending on what is given about the original circuit
- It is the same resistance, R_{eff} , value for both the Thévenin and the Norton circuits, found as R_{eq} with the sources removed (SC for V-sources, OC for I-sources)

171



L12 Learning Objectives

- a. Represent *any* (non-horizontal) linear IV characteristic by a series combination of a voltage source and a resistor (Thévenin equivalent circuit).
- b. Represent *any* (non-vertical) linear IV characteristic by a parallel combination of a current source and a resistor (Norton equivalent circuit).
- c. Find the parameters of Thévenin and Norton equivalent circuits, R_{eff} , V_T , and I_N when given a circuit.

172

Lecture 13: Norton and IV tools

- Norton
- Source Transformations
- Superposition

173

Thevenin and Norton Equivalents

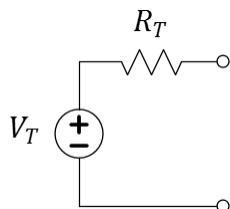

The circuit on the left and the circuit on the right can be made to behave identically by the choice of values as seen through the terminals.

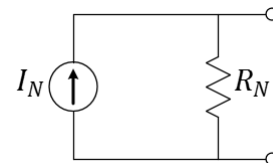

- Either can be used to represent universal: $I = I_{sc} - \frac{I_{sc}}{V_{oc}} V$
- Contain all information on how circuits interact with other circuits
- Loses information on power dissipation WITHIN the circuit

174



Norton

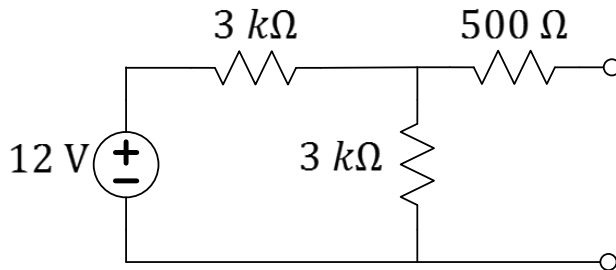

Q: What is the Norton equivalent for the circuit above?

175



Source Transformations

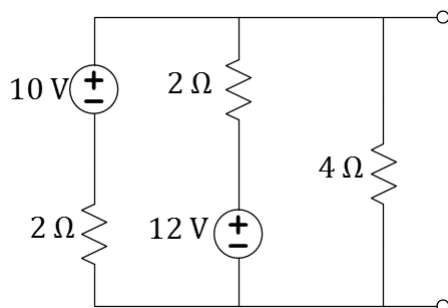

“Source transformations” involve changing Thevenin subcircuits into Norton and Norton subcircuits into Thevenin to gain an advantage in absorbing another part of the circuit. Continue until the entire circuit has been reduced to either a Thevenin or Norton equivalent.

Q: Use “source transformations” to find the Thevenin equivalent of the circuit above.

176

Explore More! Superposition

Q: Find I for all three circuits and discuss.

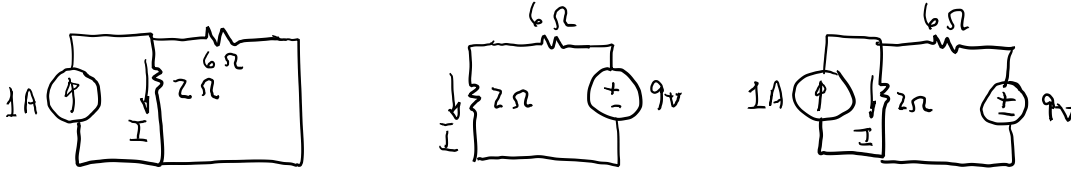

Superposition Theorem. The total current in any part of a linear **circuit** equals the algebraic sum of the currents produced by each source separately. To evaluate the separate currents to be combined, replace all other voltage sources by short **circuits** and all other current sources by open **circuits**.

From: <http://hyperphysics.phy-astr.gsu.edu/hbase/electric/suppos.html>

177

What are the possible strategies to find I ?

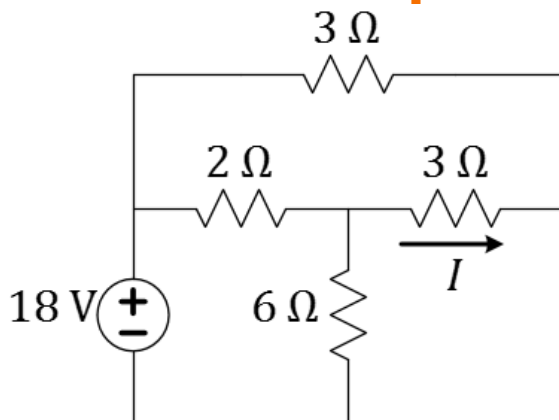

Q: Is one of the resistors in parallel with the voltage source? If so, which?

Q: What is the value of the labeled current?

178



More...

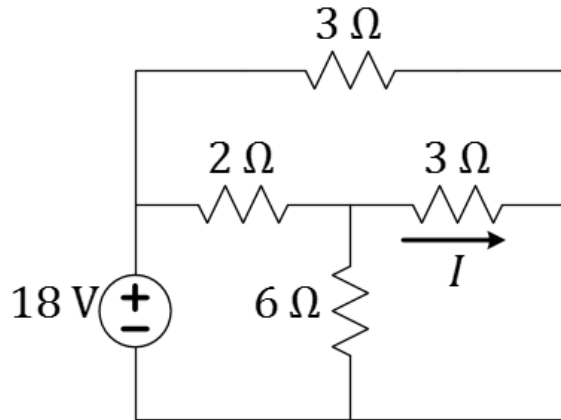

179



L13 Learning Objectives

- Explain equivalency of Thevenin and Norton by matching points on the IV.
- Solve circuits for the Norton Equivalent
- Use Source Transformations to reduce a circuit to Thevenin and/or Norton
- Use Superposition to reduce a tougher circuit analysis to analysis of two or more single-supply circuits.

180



Lecture 14: Node Method For Circuit Analysis

- Review of circuit-solving strategies
- Node Method steps
- Node Method with a “floating” source
- Practice with the Node Method

181



The Node Method

1. Identify or pick “ground” (0 V reference)
2. Label all the node voltages
(use values when you can; variables when you must)
3. Use KCL at convenient node(s)/supernode(s)
4. Use voltages to find the currents

182

Try Node Method

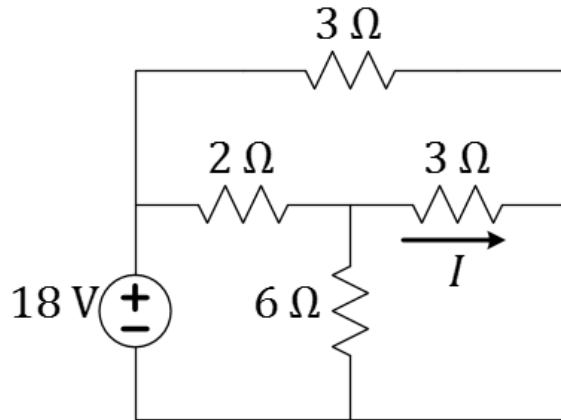

183

Node method is a good strategy for this problem because it contains two sources

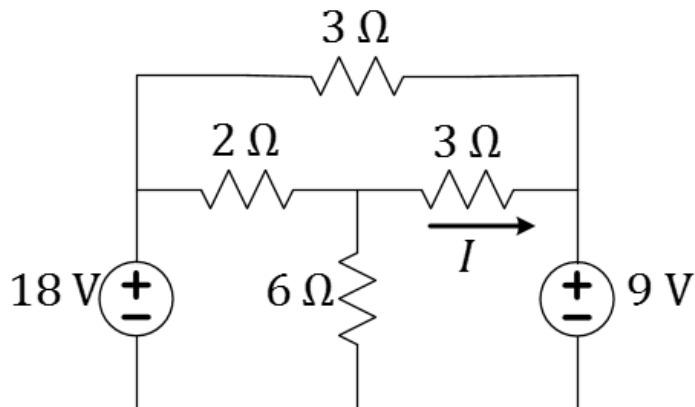

- A. 1
- B. 2
- C. 3
- D. 4
- E. 5

Q: How many nodes are in the circuit?

Q: What is the value of the labeled current?

184



A *floating* voltage source: relates two nodes but has no known relationship to ground

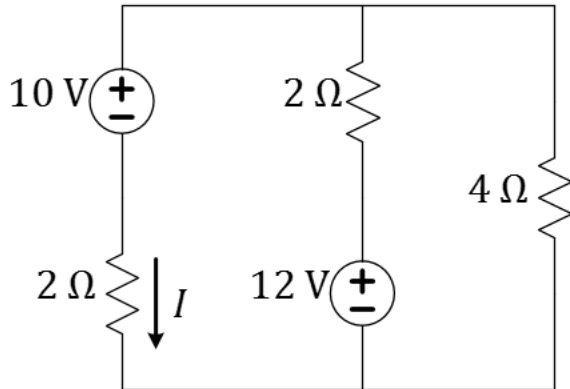

Q: How many nodes are in the circuit?

- A. 1
- B. 2
- C. 3
- D. 4
- E. 5

Q: What is the value of the labeled current?

185



Voltage across a current source is unknown

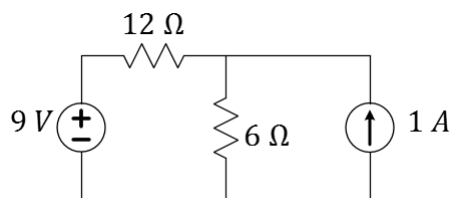

Q: What is the power supplied or consumed by each element?

186



Sometimes two or more node voltages are unknown (more challenging!)

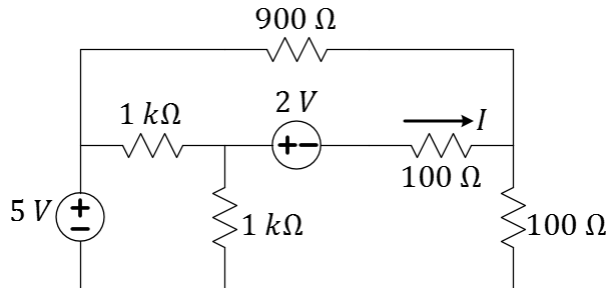

Q: What is the value of I in the circuit above?

187



L14 Learning Objectives

- Outline (list, describe) steps of the Node Method
- Use these steps to speed the process of performing circuit analysis via KCL/KVL/Ohm's
- Identify circuit patterns in which different techniques might simplify the process of finding a solution (Practice!)

188



L15: Exercises; Characterizing Sensors

- More exercises on Node Method
- Keys to characterizing sensors for your Final Project!

189

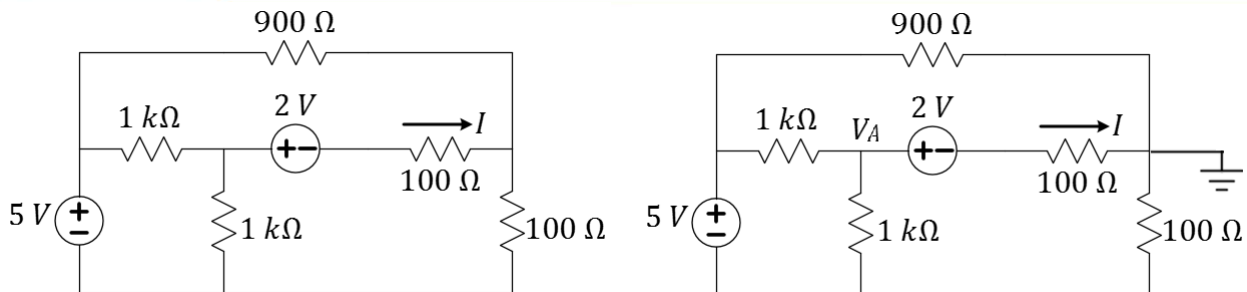

Q: What is the value of I in the circuit above?

Q: What is the value of V_A in the circuit above?

190



Characterizing Resistive Sensors

- A resistive sensor changes resistance as its environment changes around it. Examples:
 - Photoresistor: resistance decreases as light intensity increases
 - Thermistor: resistance decreases as it warms
 - Flex sensor: resistance increases as it bends
- The obvious part of the characterization is to measure the resistance under various conditions.
- The less obvious task is to use your data to PREDICT how it will behave in the final circuit and to VERIFY your prediction!

191



Example: Resistive Sensors

Consider a photoresistive sensor used in a voltage divider. Sketch below the steps to characterizing it...

192



L15 Learning Objectives

- a. Understand sensor types
- b. Provide a complete measure-model-and-predict analysis of sensors

Lecture 16: Introduction to Diodes

- Diode IV characteristics
- Connecting diode to a linear circuit
- Piecewise linear models of diodes

Recommended: <https://learn.sparkfun.com/tutorials/diodes>

195

Diode as a two-terminal device

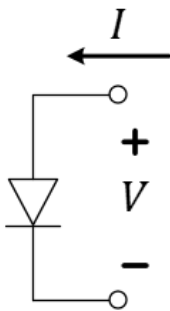

Made out of *semiconductor* materials like Si, Ge, AlGaAs, GaN with some additives called *dopants*.

Major applications: lighting, electronics

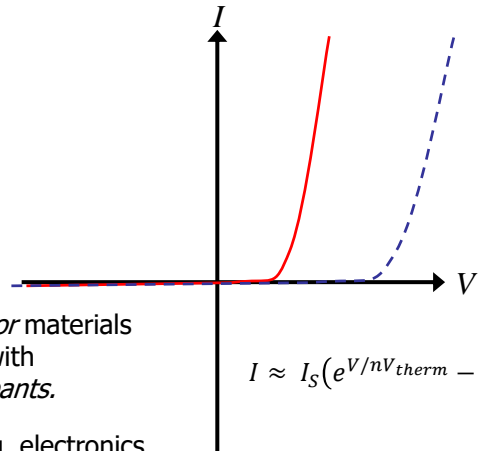

Q: Based on the exponential equation for IV, can the diode supply power?

- A. Yes
- B. No

196

Connecting diode to a linear circuit

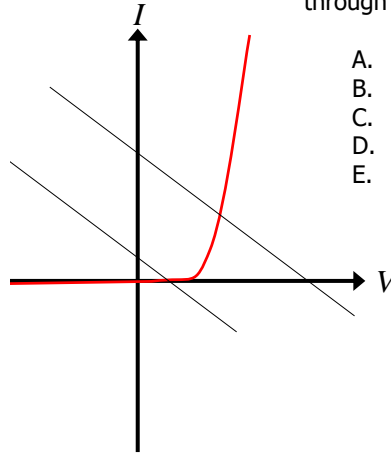
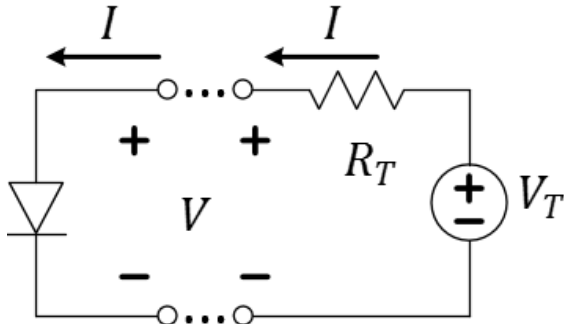

Q: What is the current flowing through the diode if $V_T < 0$?

- A. Large and negative
- B. Tiny and negative
- C. 0
- D. Tiny and positive
- E. Large and positive

We can solve graphically for an operating point. For an LED more current means more light.

Modeling diode with linear IV segments

Instead of looking for graphical solutions, we can approximate the diode with two line segments, corresponding to diode's regimes of operation.

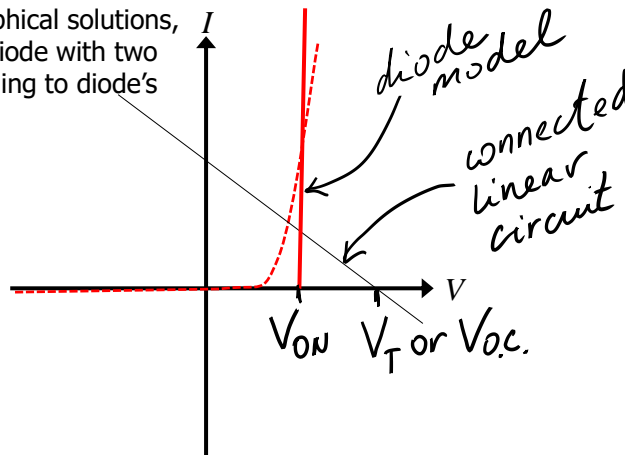
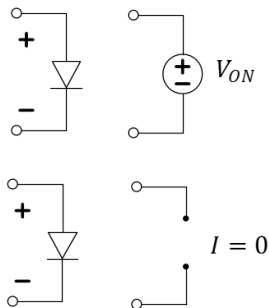

Q: What is the minimum V_T of the connected linear circuit which causes current to flow through the diode assuming the IV model?

- A. 0 V
- B. V_T
- C. V_{OC}
- D. V_{ON}
- E. None of these.

Different diode types have different V_{ON}

Diode Type	$V_{ON}(V)$	Applications
Silicon	0.6-0.7	General; integrated circuits; switching, circuit protection, logic, rectification, etc.
Germanium	~0.3	Low-power, RF signal detectors
Schottky	0.15-0.4	Power-sensitive, high-speed switching, RF
Red LED (GaAs)	~2	Indicators, signs, color-changing lighting
Blue LED (GaN)	~3	Lighting, flashlights, indicators
"Ideal"	0	Can neglect V_{ON} for high voltage applications

Q: What is the power dissipated by a Ge diode if 30 mA is flowing through it?

- A. 3 mW
- B. 9 mW
- C. 30 mW
- D. 90 mW
- E. 900 mW

199

Diode circuit examples (offset ideal model)

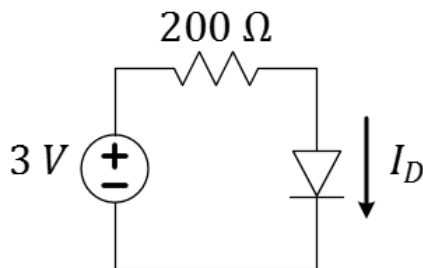

Assume offset-ideal model with $V_{ON} = 0.7$ (common Si diodes)

Q: What is the current through the diode?

- A. 15 mA
- B. 11.5 mA
- C. 5 mA
- D. 1.15 mA
- E. 0 mA

200

Diode circuit examples (offset ideal model)

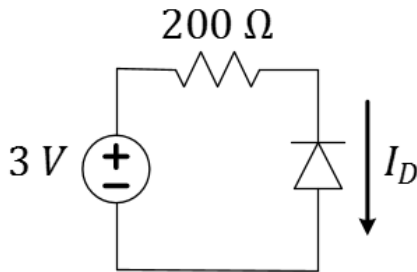

Assume offset-ideal model with $V_{ON} = 0.7$ (common Si diodes)

Q: What is the current through the diode?

- A. 15 mA
- B. 11.5 mA
- C. 5 mA
- D. 1.15 mA
- E. 0 mA

201

Diode circuit examples (offset ideal model)

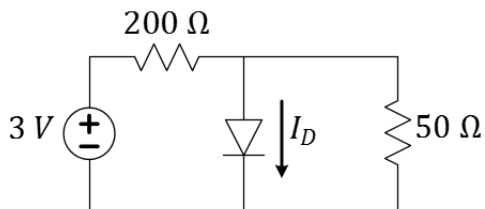

Assume offset-ideal model with $V_{ON} = 0.7$ (common Si diodes)

Q: What is the current through the diode in the circuit?

$I_D =$

- A. -11.5 mA
- B. -2.5 mA
- C. 0 mA
- D. $+2.5 \text{ mA}$
- E. $+11.5 \text{ mA}$

202

Back-to-back diodes in series are modeled by OIM as an open circuit

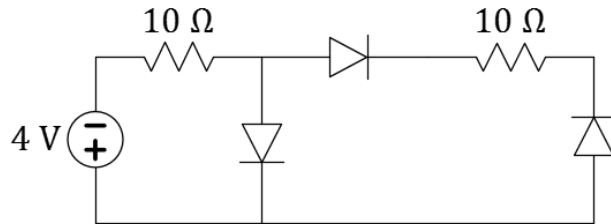

Q: Assume OIM with $V_{ON} = 0.7 \text{ V (Si)}$
What is the current through the left-most diode?

- A. 0 Amps
- B. 0.2 Amps
- C. 0.33 Amps
- D. 0.4 Amps
- E. 3.3 Amps

203

L16 Learning Objectives

- a. Draw a "typical" diode IV curve and describe its shape
- b. Explain how to use graphical analysis to find the operating point of a diode connected to a linear circuit
- c. Describe the offset ideal diode model (open, V-source)
- d. Solve simple circuit problems with one diode, given V_{ON}

204

Lecture 17: Diode Circuits

- Guess-and-check for diode circuits
- Current-limiting resistors and power dissipation
- Voltage-limiting (clipping) diode circuits

205

Guess-and-check example

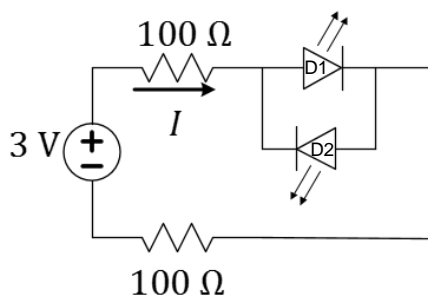

Assume OIM with $V_{ON} = 2\text{ V}$ (red LED)

Q: What is the current supplied by the voltage source?

Q: What is the power dissipated in each diode?

- | | |
|--------------------|--------------------|
| D1: | D2: |
| A. -20 mW | A. -20 mW |
| B. -10 mW | B. -10 mW |
| C. 0 mW | C. 0 mW |
| D. 10 mW | D. 10 mW |
| E. 20 mW | E. 20 mW |

206

Another guess-and-check example

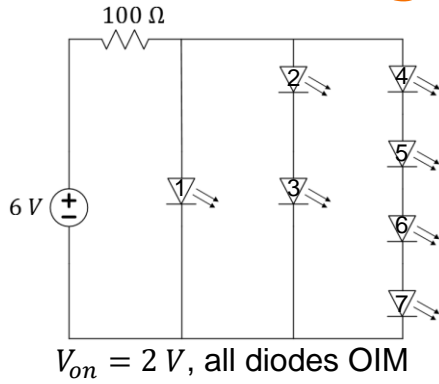

Q: How many red LEDs are turned on in the circuit?

- A. 1
- B. 2
- C. 3
- D. 4
- E. 7

ECE Spotlight...

The first visible-light LED was developed by University of Illinois alumnus (and, later, professor) Nick Holonyak, Jr., while working at General Electric in 1962 with unconventional semiconductor materials. He immediately predicted the widespread application of LED lighting in use today.

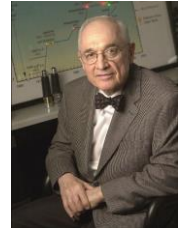

207

Current-limiting resistors for LEDs

Assume OIM with $V_{ON} = 3.3\text{ V}$ (blue LED)

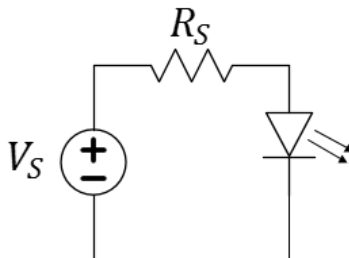

Q: How many 1.5 V batteries are needed to turn on the LED?

- A. 1
- B. 2
- C. 3
- D. 4
- E. 5

Q: What is the series resistance, R_S , needed to get 16 mA through the LED?

- A. $5\ \Omega$
- B. $10\ \Omega$
- C. $25\ \Omega$
- D. $50\ \Omega$
- E. $75\ \Omega$

Q: What is the resulting power dissipation in the diode?

- A. 19 mW
- B. 32 mW
- C. 53 mW
- D. 100 mW
- E. 320 mW

208

Setting voltage limits with diodes

Assume OIM model with $V_{ON} = 0.3$ V (Ge diode)

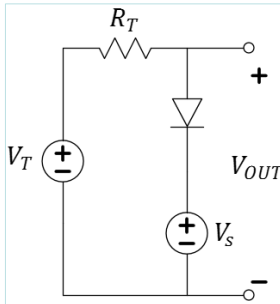

Q: What is the possible range of the output voltages?

$V_{out} \in$

- A. $(-\infty, V_S + 0.3]$
- B. $[V_S + 0.3, 0]$
- C. $[V_S - 0.3, V_S + 0.3]$
- D. $[V_S - 0.3, \infty)$
- E. $[V_S + 0.3, \infty)$

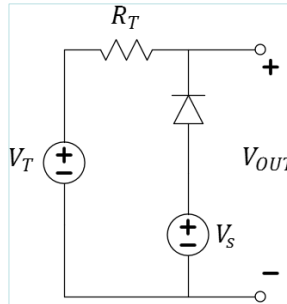

Q: What is the possible range of the output voltages?

$V_{out} \in$

- A. $(-\infty, V_S + 0.3]$
- B. $[V_S + 0.3, 0]$
- C. $[V_S - 0.3, V_S + 0.3]$
- D. $[V_S - 0.3, \infty)$
- E. $[V_S + 0.3, \infty)$

209

L17 Learning Objectives

- a. Solve circuit analysis problems involving sources, resistances, and diodes
- b. Estimate power dissipation in diode circuits
- c. Select appropriate current-limiting resistors
- d. Determine voltage limits and waveforms at outputs of diode voltage-clipping circuits

210

Lecture 18: Diode Applications

- Voltage clipping
- Rectifiers
- Flyback diode (lab)
- Instructor option...

211

A voltage-clipping circuit sets maximum or minimum output voltage

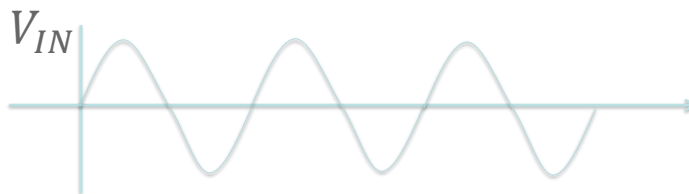
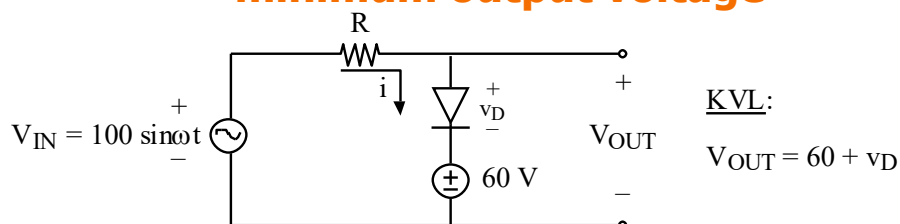

Q: If the input voltage waveform is shown, what is the output waveform, assuming an ideal diode model ($V_{ON} = 0 \text{ V}$)?

212

Half-Wave Rectifier

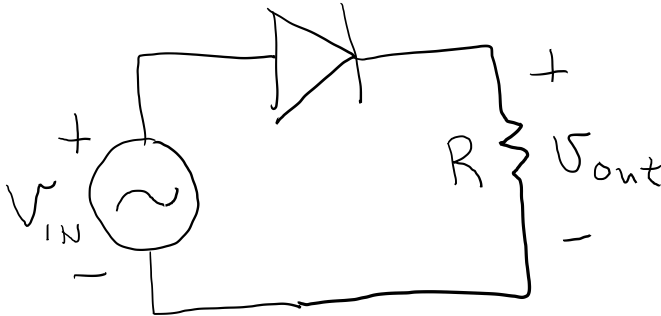

Q: Assume $V_{on} = 0\text{ V}$.
Then $V_{out} = 0$ when

- A. $v_{in} > 0$.
- B. $v_{in} < 0$.
- C. Neither of these conditions cause $V_{out} = 0$.

213

Full-Wave Rectifier

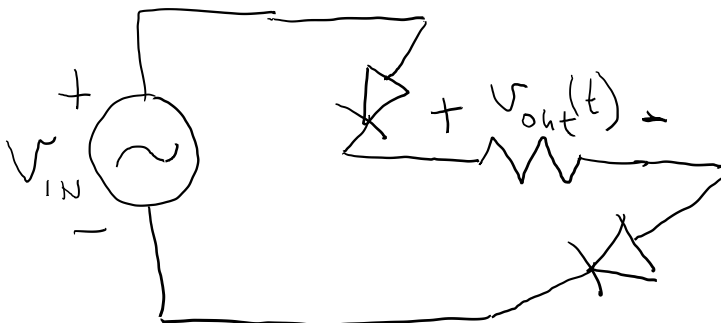

Q: Assume $V_{on} = 0\text{ V}$ for both diodes.
Then $V_{out} = 0$ when

- A. $v_{in} > 0$.
- B. $v_{in} < 0$.
- C. Neither of these conditions cause $V_{out} = 0$.

Q: Discuss limitations on this device when $V_{on} > 0$.

214

Flyback Diode: Motor protection

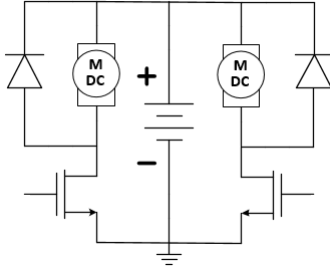

This diode is known by many other names, such as kickback diode, snubber diode, commutating diode, freewheeling diode, suppression diode, clamp diode, or catch diode. -Wikipedia on Flyback Diode

Q: Assume $V_{on} = 0\text{ V}$ for both diodes. Then $V_{out} = 0$ when

- A. $v_{in} > 0$.
- B. $v_{in} < 0$.
- C. Neither of these conditions cause $V_{out} = 0$.

Q: Discuss limitations on this device when $V_{on} > 0$.

215

Instructor Option

216



Instructor Option

217



L18 Learning Objectives

- a. Determine voltage limits and waveforms at outputs of diode voltage-clipping circuits

218

L19: The Bipolar Junction Transistor (BJT)

- BJT is a controlled current source...
 - current amplifier
- The three operating regimes of a BJT
- Controlling a resistive load with a BJT
- Solving for saturation condition

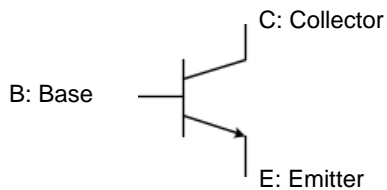

ECE Spotlight...

John Bardeen, the co-inventor of the transistor, was also the Ph.D. advisor at the University of Illinois for Nick Holonyak, Jr. of LED fame.



219

IV Characteristic of a 3-terminal Device??

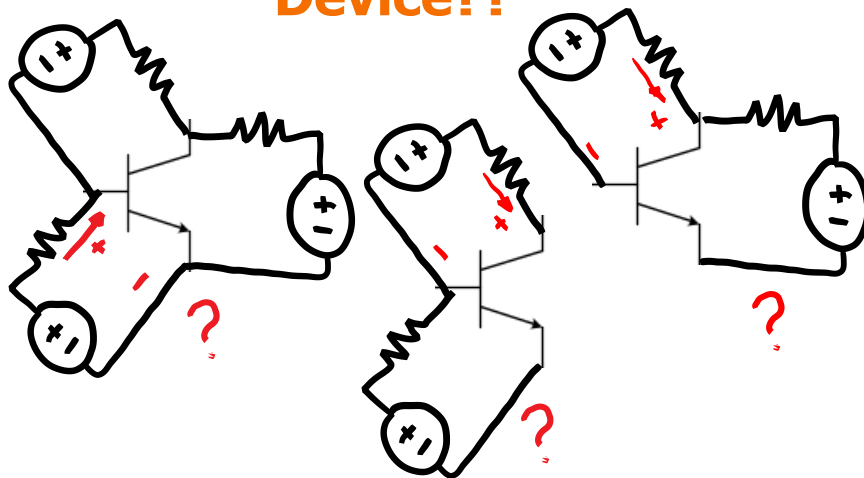

No single way to connect three-terminal device to a linear circuit.

220

ECE110 considers only the “common-emitter” configuration

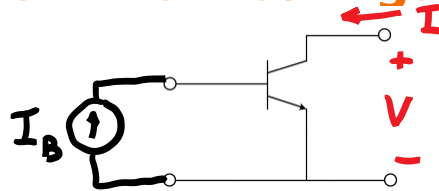

If we fix I_B , we can measure the resulting I and V at the other side.



221

The BJT's “common-emitter NPN” model

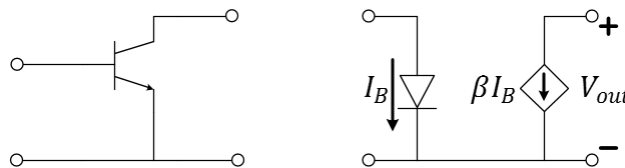

Constraints:

- Limited current range: $\beta I_B \geq 0$
- Limited voltage range: $V_{out} > 0$

Q: Given these constraints, can this “dependent” current source deliver power?

- Yes, all current sources can supply power
- No, this current source cannot supply power
- Neither A or B is correct.

222

Two Loops Coupled by Current Equation

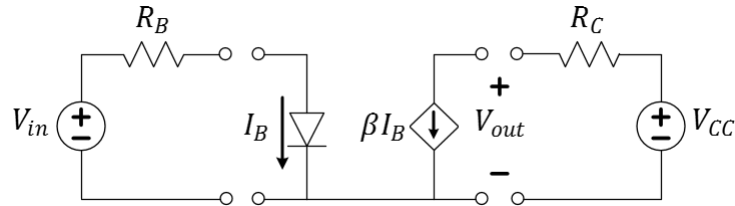

Constraints:

- Limited current range: $0 \leq \beta I_B \leq I_{max}$ (implied by V_{min})
- Limited voltage range: $V_{out} \geq V_{min} \approx 0$

Q: Right-side KVL: Find an equation relating I_{max} to V_{min} .

Q: Left-side KVL: Find the smallest V_{in} such that $I_B > 0$ (if $V_{on} = 0.7 V$)?

Q: What is I_B if $V_{in} = 3 V$ and $R_B = 4.6 k\Omega$?

Q: Let $V_{CC} = 6 V$, $R_C = 580 \Omega$, $V_{min} = 0.2 V$, $\beta = 100$. What is I_C under the same input settings as the previous question?

223

BJT in Active Region

BJT datasheet parameters:

- $\beta = 100$
- $V_{BE,on} = 1 V$
- $V_{CE,sat} = 0.2 V$

Q: Find I_B .

Q: Find I_C .

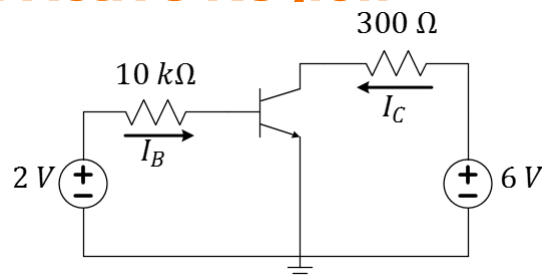

- A. $I_B = 0 \mu A$
- B. $I_B = 1 \mu A$
- C. $I_B = 2 \mu A$
- D. $I_B = 10 \mu A$
- E. $I_B = 100 \mu A$

224

BJT in Cutoff

BJT datasheet parameters:

- $\beta = 100$
- $V_{BE,on} = 1\text{ V}$
- $V_{CE,sat} = 0.2\text{ V}$

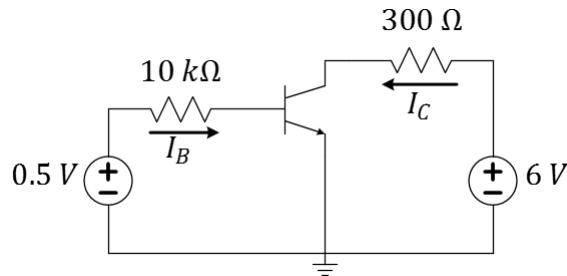

Q: Find I_B .

Q: Find I_C .

225

BJT in Saturation

BJT datasheet parameters:

- $\beta = 100$
- $V_{BE,on} = 1\text{ V}$
- $V_{CE,sat} = 0.2\text{ V}$

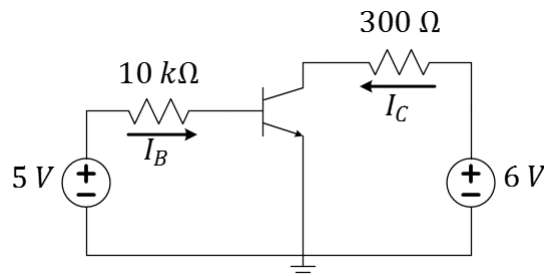

Q: Find I_B .

Q: Find I_C .

226

BJT Exercise

BJT datasheet parameters:

- $\beta = 100$
- $V_{BE,on} = 1\text{ V}$
- $V_{CE,sat} = 0.2\text{ V}$

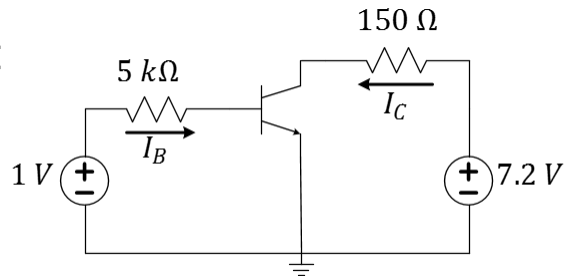

Q: Find I_C and identify in which regime the transistor is operating.

227

BJT Exercise

BJT datasheet parameters:

- $\beta = 100$
- $V_{BE,on} = 1\text{ V}$
- $V_{CE,sat} = 0.2\text{ V}$

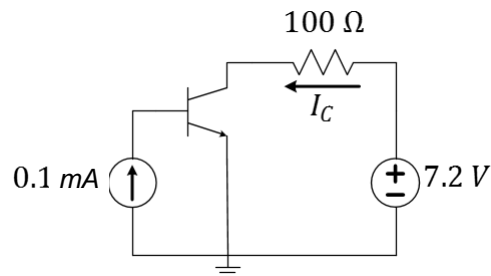

Q: Find I_C and identify in which regime the transistor is operating.

Q: Determine the power consumed by the transistor.

228



L19 Learning Objectives

- Identify B, E, C terminals on an npn-BJT symbol
- Explain BJT's three regimes of operation
- Calculate active-regime I_C using V_{BEon} in the BE loop
- Calculate maximum I_C based on $V_{CE,sat}$ and CE loop
- Calculate I_C given complete biasing conditions and transistor parameters, no matter which regime
- Calculate the power dissipated by a transistor

Lecture 20: BJT IV Characteristics

“Transistor. This is an abbreviated combination of the words “transconductance” or “transfer”, and “varistor”. The device logically belongs to the varistor family, and has the transconductance or transfer impedance of a device having gain, so that this combination is descriptive.” Bell Labs memo

- Interpreting CE junction IV curves for transistor parameters
- Interpreting load line IV curves
- Analysis of IV curves for the (I,V) operating point
- Explore the saturation condition
- Solving transistor-regime problems

231

BJT IV curves of the CE junction

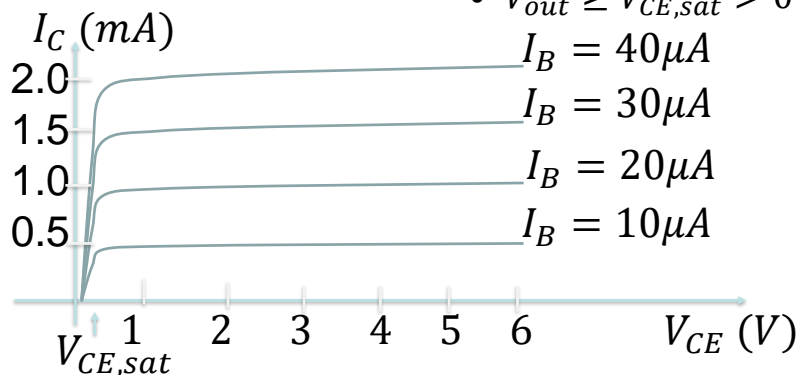
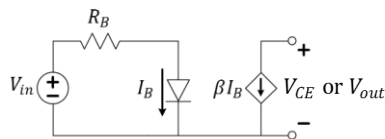

Constraints:

- $0 \leq \beta I_B \leq I_{C,sat}$
- $V_{out} \geq V_{CE,sat} > 0$

Q: Use the IV plots to estimate the value of β .

- A. 10
- B. 20
- C. 50
- D. 100
- E. 200

232

Extracting information from the IV curve(s)

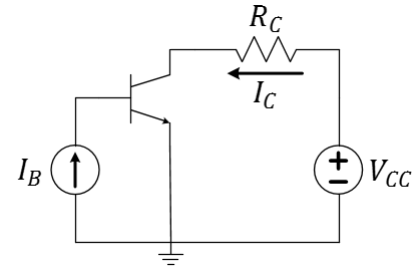
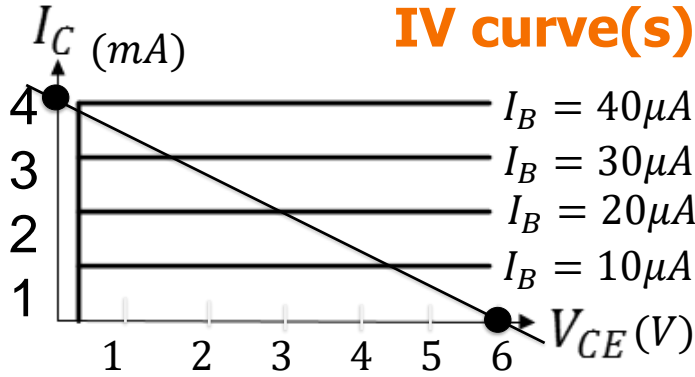

- Q: What is β and $V_{CE,sat}$?
- Q: What is V_{CC} ?
- Q: What is R_C ?
- Q: What is $I_{C,sat}$?
- Q: Which I_B results in saturation?

- A. $I_{B@SAT} = 40\mu A$
- B. $I_{B@SAT} = 30\mu A$
- C. $I_{B@SAT} = 20\mu A$
- D. $I_{B@SAT} = 10\mu A$
- E. $I_{B@SAT} = 0\mu A$

233

BJT Exercise

$V_{BE,on} = 0.7 V$

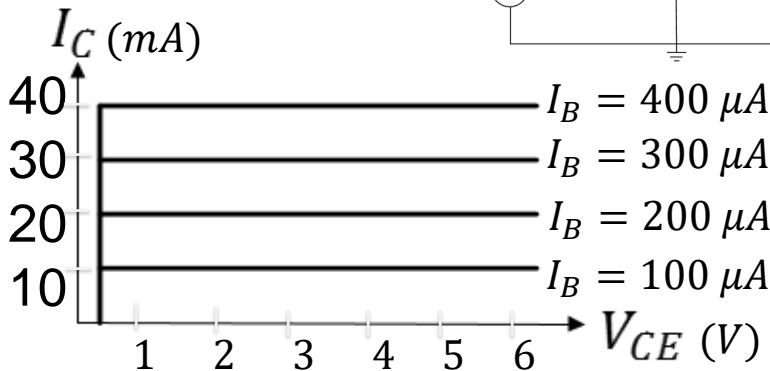
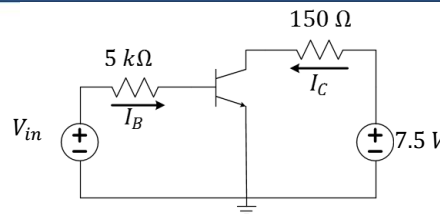

- Q: Estimate the operating point (I_C, V_{CE}) when $V_{in} = 1.7 V$.
- Q: What value of V_{in} would drive the transistor to the edge of saturation?

- A. $V_{in@SAT} = 0.3 V$
- B. $V_{in@SAT} = 0.7 V$
- C. $V_{in@SAT} = 1.7 V$
- D. $V_{in@SAT} = 2.5 V$
- E. $V_{in@SAT} = 3.1 V$

234

BJT Exercise

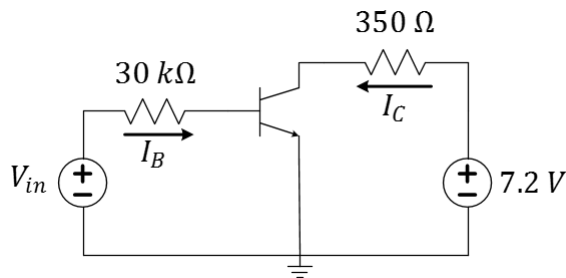

BJT datasheet parameters:

- $\beta = 100$
- $V_{BE,on} = 0.7 V$
- $V_{CE,sat} = 0.2 V$

Q: What value of V_{in} would drive the transistor to the edge of saturation?

Q: How does your answer change if $30 k\Omega$ were replaced with $60 k\Omega$?

Q: How does your answer change if, instead, $350 \Omega \rightarrow 700 \Omega$?

Q10:

- $V_{in@sat}$ goes up
- $V_{in@sat}$ goes down
- $V_{in@sat}$ stays the same

Q11:

- $V_{in@sat}$ goes up
- $V_{in@sat}$ goes down
- $V_{in@sat}$ stays the same

235

BJT circuit analysis: working back to V_{in}

BJT Datasheet: $\beta = 100, V_{BE,on} = 0.7V, V_{CE,sat} = 0.2V$

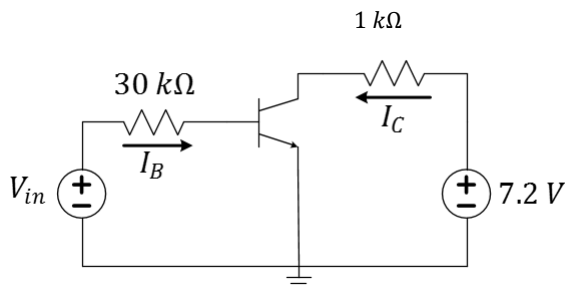

Q: Find V_{in} such that $V_{CE} = 3 V$

236

BJT circuit analysis

BJT Datasheet:

- $\beta = 100$,
- $V_{BEon} = 0.7 V$
- $V_{CE,sat} = 0.2 V$

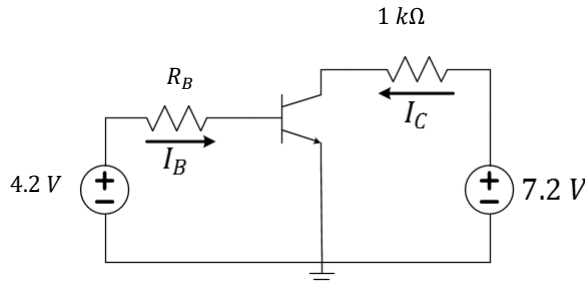

Q: Choose R_B such that the BJT is driven to the edge of saturation.

237

L20 Learning Objectives

- Find β and $V_{CE,sat}$ for a given BJT IV characteristic
- Find V_{CC} and R_C from the IV characteristic of the load line
- Compute $I_{C,sat}$ from V_{CC} , $V_{CE,sat}$, and R_C
- Identify the BJT CE operating point given IV characteristics
- Solve numerically for unknown parameters among $\{V_{in}, R_B, I_B, \beta, V_{BE,on}, V_{CE,sat}, I_C, R_C, V_{CC}, I_{C,sat}\}$ when given some or all of the other values
- Determine settings to drive transistor into a desired regime

238

Lecture 21: The BJT Voltage Amplifier

- Relating V_{out} to V_{in}
- Node notation for V_{CC}
- Voltage transfer function
- AC signal amplification

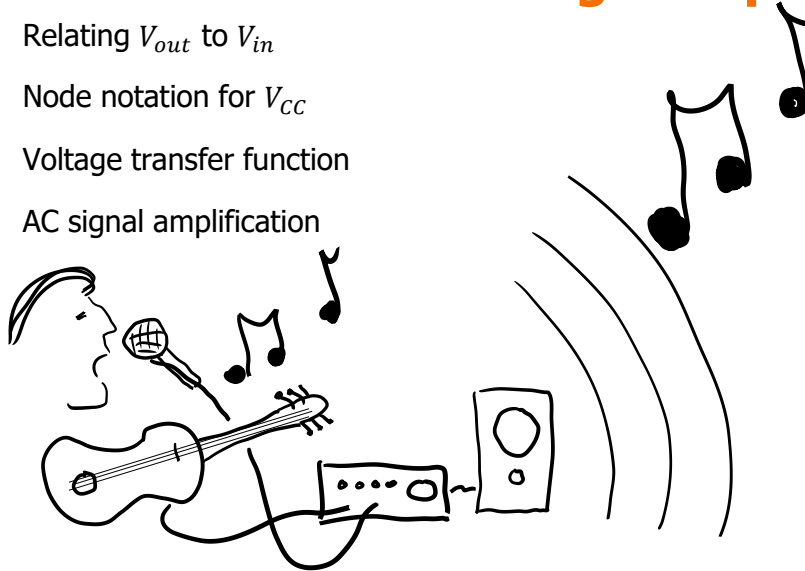

239

Calculating V_{out} from V_{in} (revisited)

BJT Datasheet:

- $\beta = 100$
- $V_{BE,on} = 0.7V$
- $V_{CE,sat} = 0.2V$

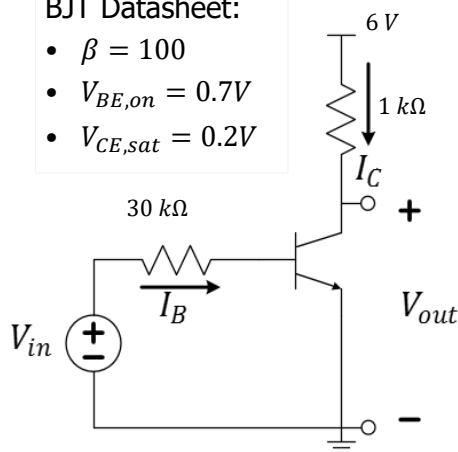

Q: What is $v_{out} = V_{CE}$ for $V_{IN} = 0.3, 1, 2.5,$ and 3.5 Volts?

240

Review of BJT operating regimes

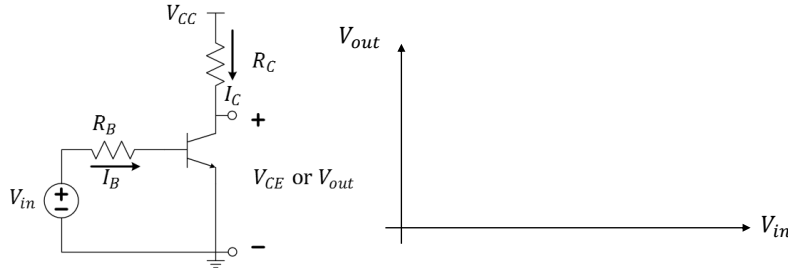

Q: What is the formula for minimum V_{IN} which causes saturation?

Regime	V_{in}	I_B	I_C	V_C

- A. $V_{in} = \frac{V_{CC} - V_{CE,sat}}{R_C}$
- B. $V_{in} = V_{CC} + V_{BE,on}$
- C. $V_{in} = V_{CE,sat} + I_B R_B$
- D. $V_{in} = V_{CC} - I_C R_C + I_B R_B$
- E. $V_{in} = V_{BE,on} + \frac{R_B}{\beta R_C} (V_{CC} - V_{CE,sat})$

241

Voltage transfer characteristics

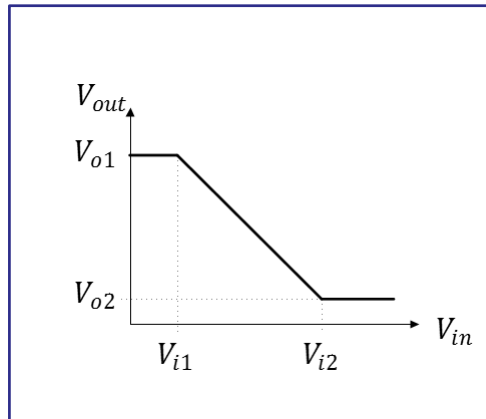
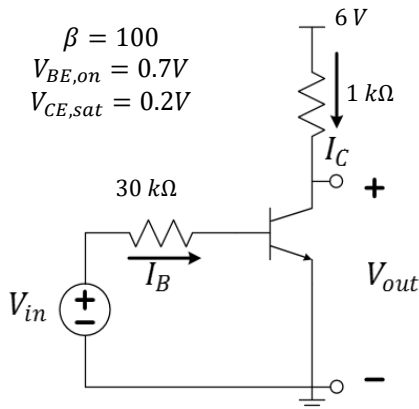

Q: What are the four values $V_{o1}, V_{o2}, V_{i1}, V_{i2}$?

Q: What is the $\frac{\Delta V_{out}}{\Delta V_{in}}$ slope in the active region?

242



Active regime for signal amplification

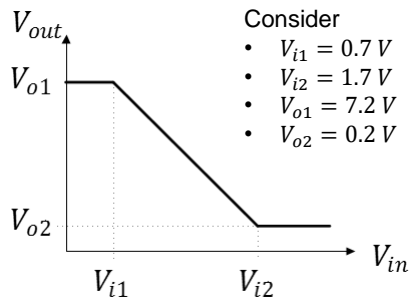

Q: If $V_{IN} = 1.2 + 0.2\cos(2\pi 100t)$,
what is the equation for V_{out} ?

Q: What is different if
 $V_{in} = 1.2 + 0.6\cos(2\pi 100t)$?

Q: What transistor regimes are entered if
 $V_{in} = 1.1 + 0.3\cos(\omega t)$?

- Active only
- Cutoff and active
- Active and saturation
- Saturation only
- Cutoff, active, and saturation

243



L21 Learning Objectives

- Explain the voltage transfer curve (V_{out} vs. V_{in})
- Find the transition points on the voltage transfer curve
- Find the slope of the active region in the transfer curve
- Determine the operating regions for an AC+DC input
- Evaluate and AC+DC output for linear amplification

244



Lecture 22: More on Transistors

- Exercises in BJTs
- Revisit MOSFET

245



Active regime for signal amplification

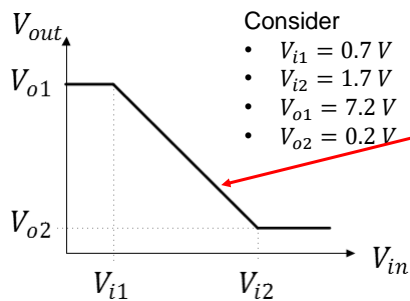

Q: Derive an equation that gives V_{out} as a function of V_{in} . Hint, find the equation of this line!

[This equation will be accurate only accurate in the linear portion of the active region.]

246

BJT Datasheet Parameters 2N5192G

ELECTRICAL CHARACTERISTICS* ($T_C = 25^\circ\text{C}$ unless otherwise noted)

Characteristic	Symbol	Min	Max	Unit
ON CHARACTERISTICS (Note 1)				
DC Current Gain ($I_C = 1.5 \text{ Adc}$, $V_{CE} = 2.0 \text{ Vdc}$) 2N5190G/2N5191G 2N5192G	h_{FE}	25 20	100 80	-
($I_C = 4.0 \text{ Adc}$, $V_{CE} = 2.0 \text{ Vdc}$) 2N5190G/2N5191G 2N5192G		10 7.0	- -	
Collector-Emitter Saturation Voltage ($I_C = 1.5 \text{ Adc}$, $I_B = 0.15 \text{ Adc}$) ($I_C = 4.0 \text{ Adc}$, $I_B = 1.0 \text{ Adc}$)	$V_{CE(sat)}$	- -	0.6 1.4	Vdc
Base-Emitter On Voltage ($I_C = 1.5 \text{ Adc}$, $V_{CE} = 2.0 \text{ Vdc}$)	$V_{BE(on)}$	-	1.2	Vdc

 $\approx \beta$
 $V_{CE,sat}$
 $V_{BE,on} \leq$

Q: Approximate the values of β , $V_{BE,on}$, and $V_{CE,sat}$ from the datasheet.

247

Field-Effect Transistors (FETs)

- Advantages of MOSFETs for IC manufacturing
- A little physics of MOSFET operation

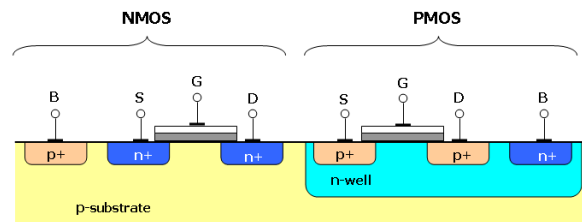

248

The Metal-Oxide-Semiconductor FET

- MOSFETs are **generally** easier to fabricate; also they scale down in size better and use less power than BJTs.
- BJTs are still used in very high-speed switching integrated circuits and they are common as “discrete” devices.

Do you know? How many transistors are in a single modern microprocessor chip?

- A. ~100,000
- B. ~1,000,000
- C. ~10,000,000
- D. ~100,000,000
- E. ~1,000,000,000

249

To Produce a Conductive “Channel”

Source and Body are tied together and $V_{GS} > V_{TH} > 0$

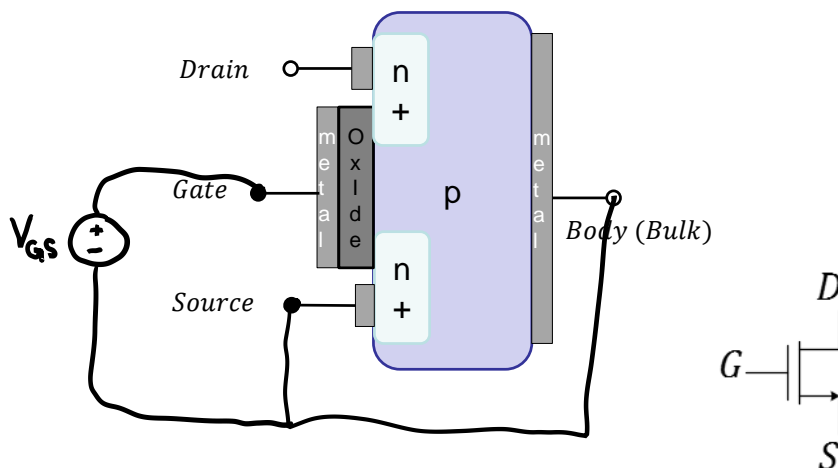

250



251



L22 Learning Objectives

- a. Derive an equation for V_{out} vs. V_{in} accurate in the linear region of the transistor.
- b. Be able to extract information from a transistor datasheet
- c. Name advantages/disadvantages of MOSFET vs BJT
- d. Describe a diagram of MOSFET physics

252

Lecture 23: Field-Effect Transistors (FETs)

- Advantages of MOSFETs for IC manufacturing
- A little physics of MOSFET operation
- MOSFET transistor regimes: operating voltages and current

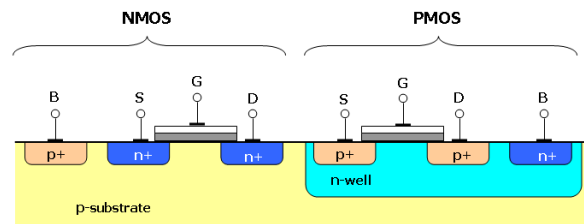

253

BJT (NPN) vs. MOSFET (n-channel) active region models

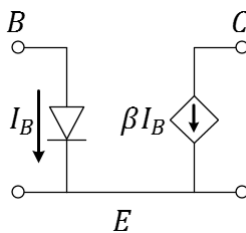

Active: $I_C = \beta I_B$

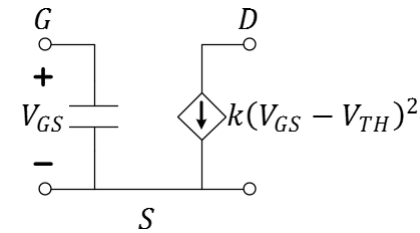

Active: $I_D = k (V_{GS} - V_{TH})^2$

ECE Spotlight...

Prof. **Rosenbaum** emphasizes the need for physically-accurate circuit models to predict and protect against electrostatic discharge.



Elyse Rosenbaum
University of Illinois

Q: What happens to drain current when $V_{GS} - V_{TH}$ doubles?

Q: What is the DC current into the gate of the MOSFET model?

Q: What are the units of k ?

Q1: the drain current...

- halves
- stays the same
- doubles
- triples
- quadruples

254

Measuring nMOS IV-curves

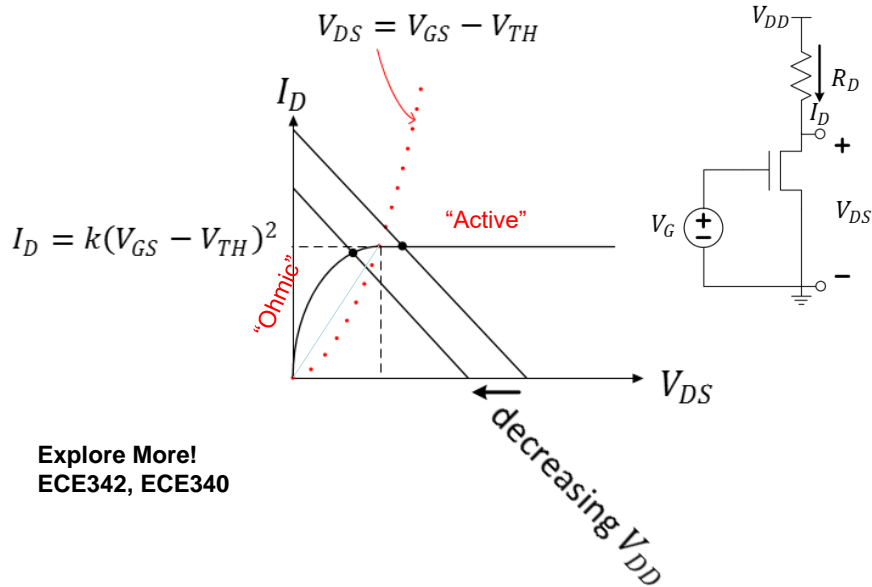

255

Family of nMOS IV-curves

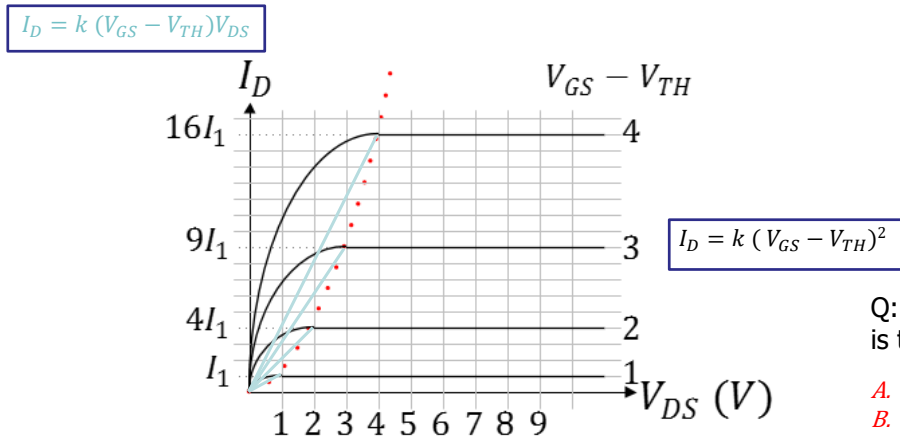

Q: If $I_1 = 100 \text{ mA}$, what is the value of k ?

- A. $k = 100 \text{ mA/V}^2$
- B. $k = 50 \text{ mA/V}^2$
- C. $k = 25 \text{ mA/V}^2$
- D. $k = 12.5 \text{ mA/V}^2$
- E. $k = 1 \text{ mA/V}^2$

256

nMOS Exercise

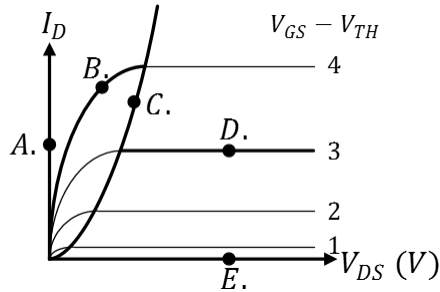

- Q: At which operating point above would the MOSFET be in "cutoff"?
- Q: At which operating point above would the MOSFET be "active"?
- Q: At which operating point above would the MOSFET be "ohmic"?

257

FET Exercise

FET datasheet:
 $V_{TH} = 2\text{ V}$
 $k = 10\text{ mA}$

$V_{DD} = 9\text{ V}$
 $R_D = 100\ \Omega$
 $V_{GS} = 5\text{ V}$

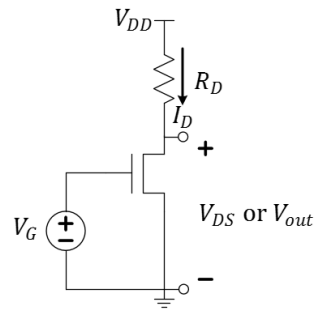
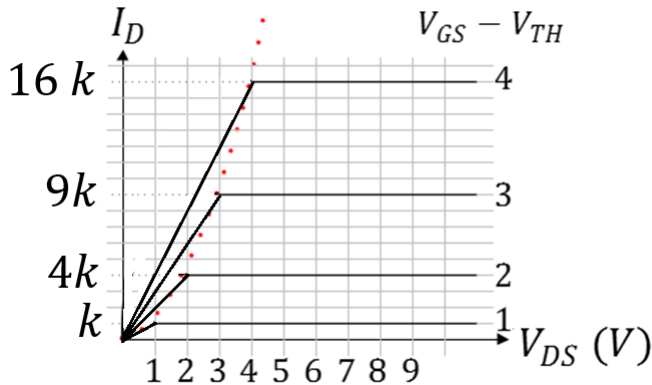

- Q: Use the IV plot to find the FET regime and operating point.

258

FET Exercise

FET datasheet:

$$V_{TH} = 2 \text{ V}$$

$$k = 10 \text{ mA}$$

$$V_{DD} = 9 \text{ V}$$

$$R_D = 100 \Omega$$

$$V_{DS} = 5 \text{ V}$$

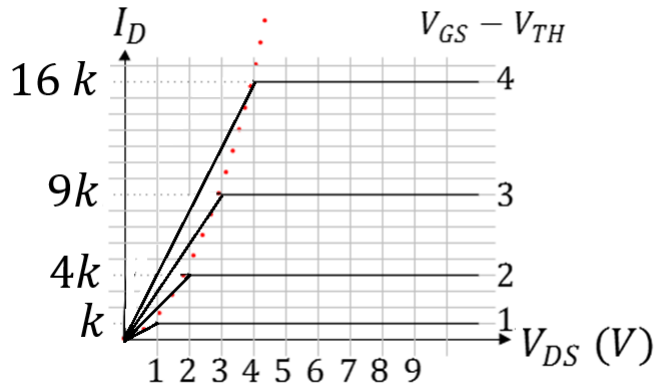

Q: Find the Gate-to-Source voltage, V_{GS} .

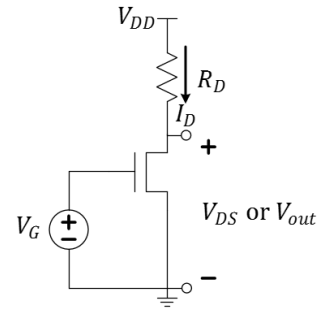

259

L23. Learning Objectives

- To recognize the physics of enhancing/creating a channel in a MOS Transistor
- To identify the regimes of nMOS with IV curves
- To solve nMOS transistor problems using IV data

260

Lecture 24: CMOS Logic

- CMOS logic and circuit models
- CMOS logic circuits and truth tables
- Switching a capacitive load

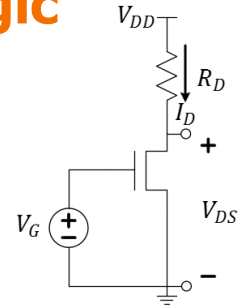

Idealized FET Model:

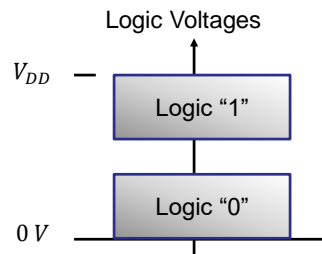
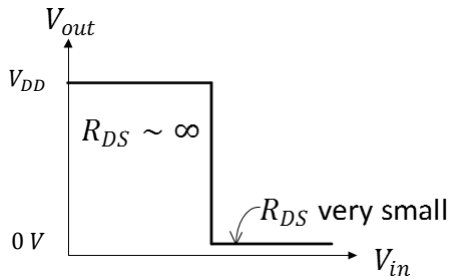

261

n-channel MOSFET

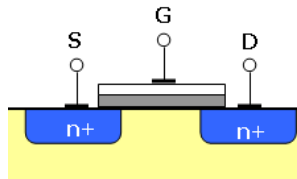

Circuit Symbol

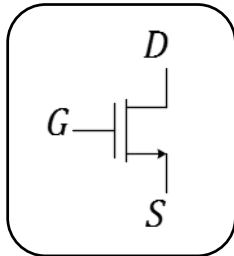

Logic Symbol

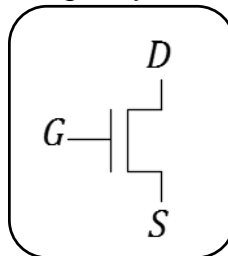

262

p-channel MOSFET

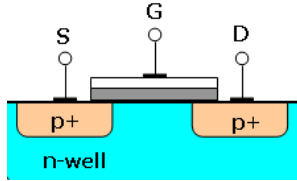

Circuit Symbol

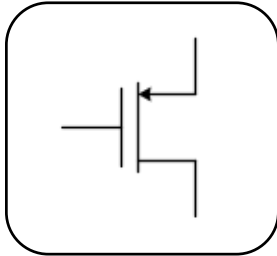

Logic Symbol

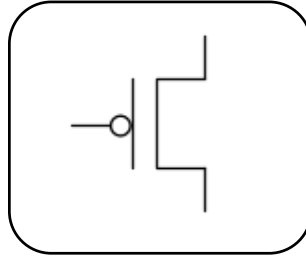

Q: What happens when a logical "0" is applied to the gate?

- A. Electrons are attracted to the gate and a channel forms.
- B. Electrons are chased from the gate and a channel is formed.
- C. The voltage is too low to effect the channel at all.

cMOS implementation of Inverter

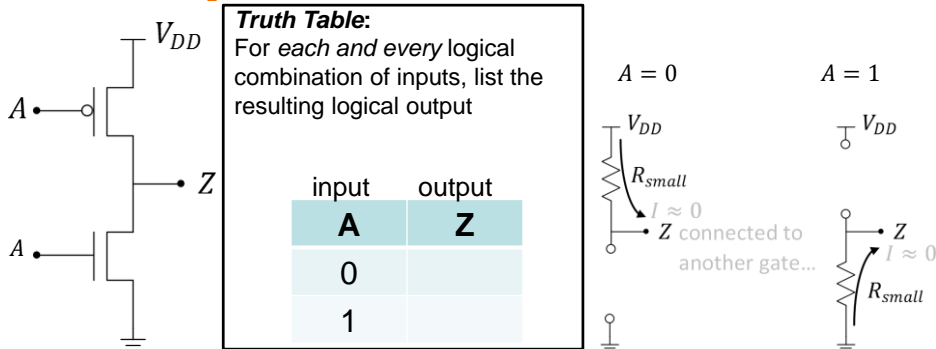

Truth Table:
For each and every logical combination of inputs, list the resulting logical output

input	output
A	Z
0	
1	

Q: What is the output voltage when the input is connected to V_{DD} ?

Q: What is the output voltage when the input is connected to GND?

Q: Complete the Logical "Truth Table".

A Two-Input cMOS Circuit

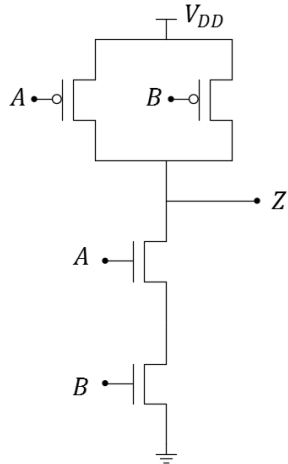

A	B	Z
0	0	1
0	1	ρ
1	0	γ
1	1	0

Q: Complete the Truth Table.

- A. $\rho = 0, \gamma = 0$
- B. $\rho = 0, \gamma = 1$
- C. $\rho = 1, \gamma = 0$
- D. $\rho = 1, \gamma = 1$
- E. Cannot determine

265

A Three-Input cMOS Circuit

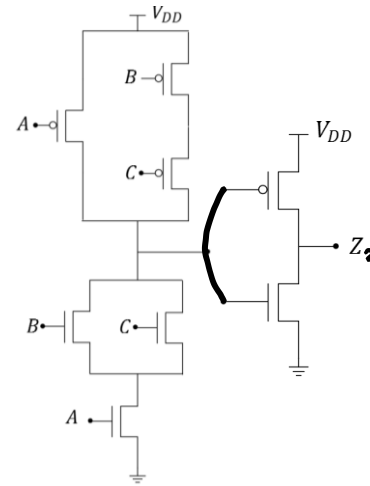
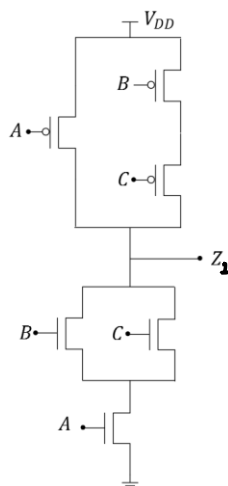

Q: Complete the Truth Tables.

266

Improperly-Constructed CMOS Circuits

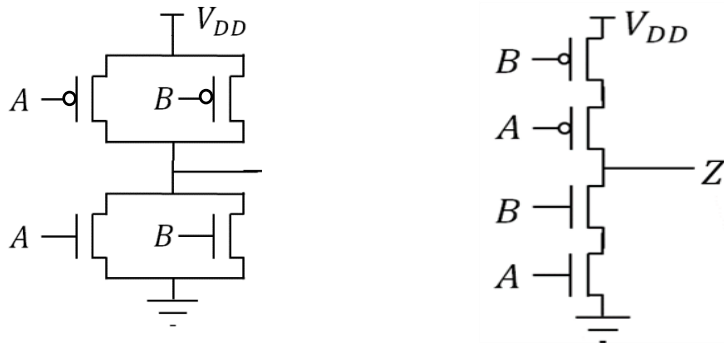

Q: Attempt to complete the Truth Tables.

267

cMOS Energy

Q: How much energy is stored in each gate ($C = 1fF$) if charged to V_{DD} ?

Q: How much energy is consumed from the voltage source to charge it?

268



Power consumed by a single switching FET

$$P = a f C V^2 n$$

a – activity factor

f – switching frequency

C – load capacitance

V – switching voltages

n – number of transistors switching

ECE Spotlight...

Prof. **Hanumolu** works to produce useful circuits that “can be implemented in small area and with minimal power consumption while operating at high [frequency].”



- Largest source of power consumption in computer chips
- Reduction of contributing factors is a technological goal

Q: How many 2 fF caps are switched at 1 V every ns to dissipate 100 W ?

Q: If the total number of transistors on a chip is 1 billion, what is a ?

269



L24. Learning Objectives

- To explain operation of a cMOS inverter
- To interpret cMOS logic and express in Truth Table form
- To calculate power consumption due to cMOS switching with capacitive loads

270

Two-Input cMOS Circuit

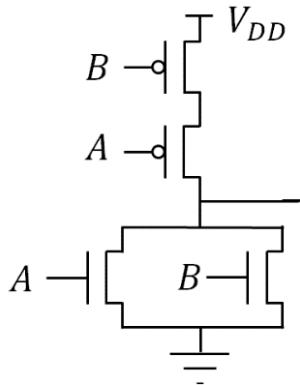

Q: Complete the Truth Table.

271

Two-Input cMOS Circuit

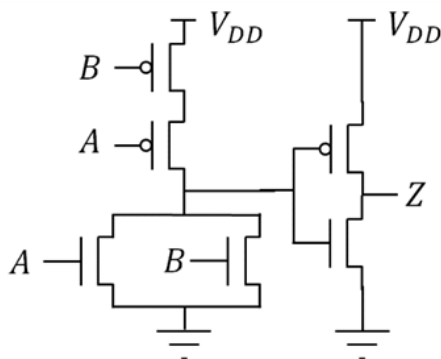

Q: Complete the Truth Table.

272

L25: Analog-to-Digital

- Noise-immunity motivation
- Describing waveforms by samples
- The sampling operation

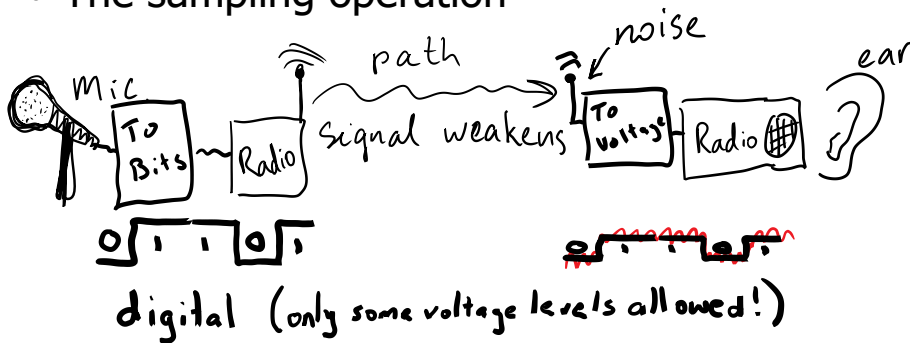

273

How Would you Sketch this Waveform?

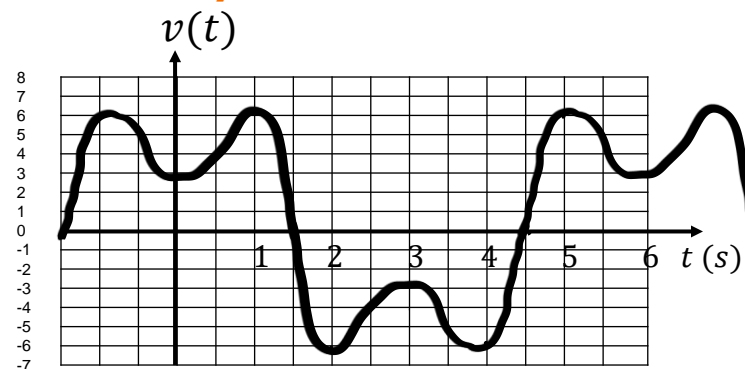

Q: What are the values at $t = 0, 2, 4,$ and 6 seconds?



Q: Is this enough information to reproduce the waveform?

274

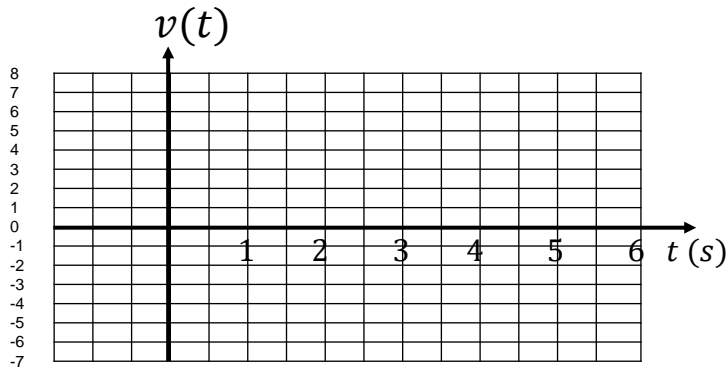
Enter Data Points of the Previous Waveform.



Q: How should one connect the data points?

- A. Point-to-point with straight lines. 
- B. Point-to-point with curvy lines. 
- C. Point-to-point, but only with horizontal and vertical lines. 

When storing these values using bits, how many should we use?
(NEXT LECTURE!)

275

Sampling: Sensing real-world data at uniform intervals

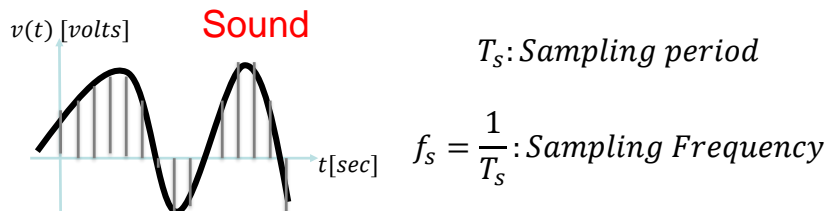

Sampled Sequence:

$$v[n] = v(t = nT_s), n \text{ integer } (n = -2, -1, 0, 1, 2, \dots)$$

Example: $y(t) = 5t$ sampled at $T_s = 2$

Answer: $y[n] = y(nT_s) = 5n \cdot 2 = 10n = \dots, -20, -10, 0, 10, 20, \dots$

276



Sampling

Sampled Sequence:

$$v[n] = v(t = nT_s), n \text{ integer } (n = -2, -1, 0, 1, 2, \dots)$$

Q: Let $v_1(t) = 2\cos(\pi t)$. Plot $v_1(t)$.

Q: Let $v_1(t) = 2\cos(\pi t)$.
If $T_s = 0.5$ s, what is $v_1[6]$?

Q: Let $v(t) = 5\cos\left(\frac{\pi}{3}t\right) - 2\cos(\pi t)$.
If $T_s = 0.5$ s, what is $v[6]$?

277



Sampling: Sensing real-world data at uniform intervals

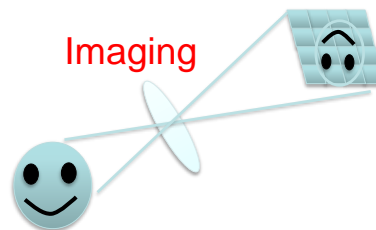

Think About It! How does sampling work in digital photography?

278



Largest Sampling Period, T_s

If you sample fast enough to catch the highs/lows on a wiggly waveform, **then** you can smoothly reconnect the data points to recreate it.

Q: Speech is intelligible if frequencies up to 3.5 kHz are preserved. What should we use for T_s ?

- A. $< \frac{1}{7} \text{ ms}$
- B. $< \frac{1}{3.5} \text{ ms}$
- C. $< 3.5 \text{ ms}$
- D. $> 3.5 \text{ ms}$
- E. $> 7 \text{ ms}$

279



L25: Learning Objectives

- a. Explain the motivation for digital signals
- b. Determine reasonable sampling interval for plotted waveforms
- c. Sample an algebraic signal given a sampling interval

280



L26: Preserving Information in A/D

- Nyquist Rate
- Quantization
- Memory Registers
- Binary Numbers
- Aliasing
- A/D block diagram
- D/A block diagram

281



Nyquist Rate: lower bound on f_s

A sampled signal can be converted back into its original analog signal without any error if the sampling rate is more than twice as large as the highest frequency in the signal.

$$f_s > 2f_{max}$$

☺No loss of information due to sampling☺

Interpolation: recreate analog with a special function!

Q: Speech is intelligible if frequencies up to 3.5 kHz are preserved. What is the Nyquist rate?

- A. 1.75 kHz
- B. 3.5 kHz
- C. 5.25 kHz
- D. 7 kHz
- E. 8 kHz

Q: Music is often filtered to include sounds up to 20 kHz. What sampling rate should we use?

282

Aliasing occurs when Sampling is sparse

When f_s is too small (T_s is too large), high-frequency signals masquerade as lower frequency signals...

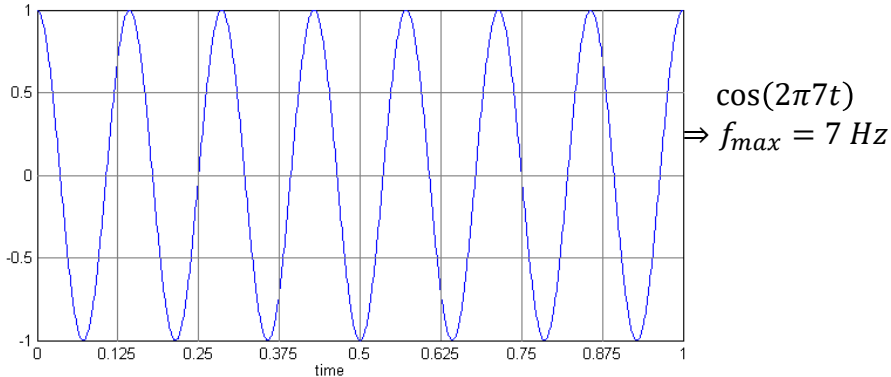

Q: When sampling at $f_s = 8 \text{ Hz}$, what is the frequency of the signal above after reconstruction?

283

Quantization: Round voltage values to nearest discrete level

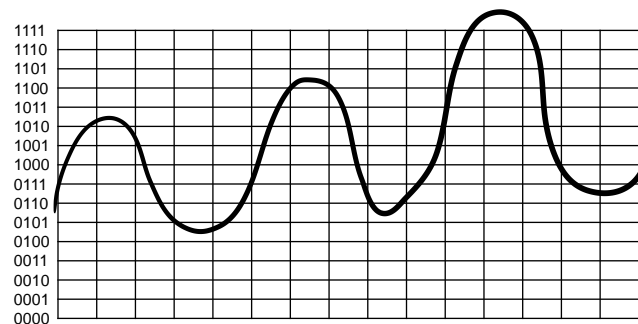

Q: Assume we sample at the vertical lines. Digitize the waveform using four-bit samples.

284



Computers are made of CMOS Circuits

- **Registers** are combinations of logic circuits that utilize electrical **feedback** to serve as computer's working memory.
- Each register element is a bit which can be 0 (low) or 1 (high)
- Example: An 8-bit register holds 8 binary values.

Choose the largest 8-bit binary value.

- A. 00001011
- B. 00010110
- C. 00010000
- D. 00001111
- E. 00000101

285



Binary Numbers

Any number system has a base, N , with N digits $\{0, \dots, N - 1\}$, and n -digit number representations with the distance from the decimal point indication what base power each digit represents.

3-digit Binary integers:

0: 0 0 0
 1: 0 0 1
 2: 0 1 0
 3: 0 1 1
 4: 1 0 0
 5: 1 0 1
 6: 1 1 0
 7: 1 1 1

Base 10: What is the number 51?

2 – digit number: 5 1
 position (in decimal): 10s place 1s place
 meaning (in decimal): $5 \times 10 + 1 \times 1$

Base 2: What is the number 101_2 ?

3 – digit number: 1 0 1
 position (in decimal): 4 2 1
 meaning (in decimal): $1 \times 4 + 0 \times 2 + 1 \times 1$

286

More bits=More levels= Less Quantization Error (Noise)

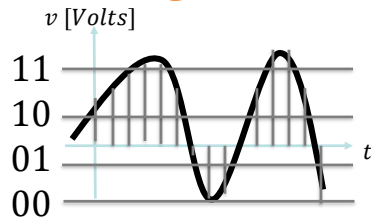

Example: 2 – bit quantizer

$$e[n] = v[n] - v_Q[n]$$

Q: If the voltages 2.93 and 5.26 are quantized to the nearest 0.25 V, what are the quantization errors?

287

3-Bit Quantizer

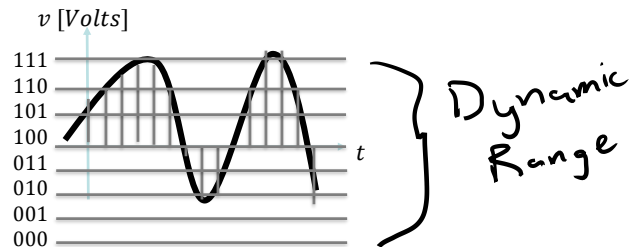

Example: 3 – bit quantizer

Q: How many levels in a 10-bit quantizer?

- A. 4
- B. 8
- C. 10
- D. 100
- E. 1024

288

Sampling + Quantization = Digitization

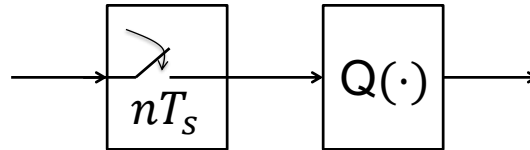

- *Sampling Rate = 1/(Sampling Period) $f_s = \frac{1}{T_s}$*
- *\uparrow Sampling Rate $\Rightarrow \uparrow$ Memory usage*
- *\downarrow Sampling Rate \Rightarrow Loss of Information?*

Q: Under what conditions on sampling and on quantization will you incur a loss of information?

289

Analog-to-Digital Converter Digital-to-Analog Converter

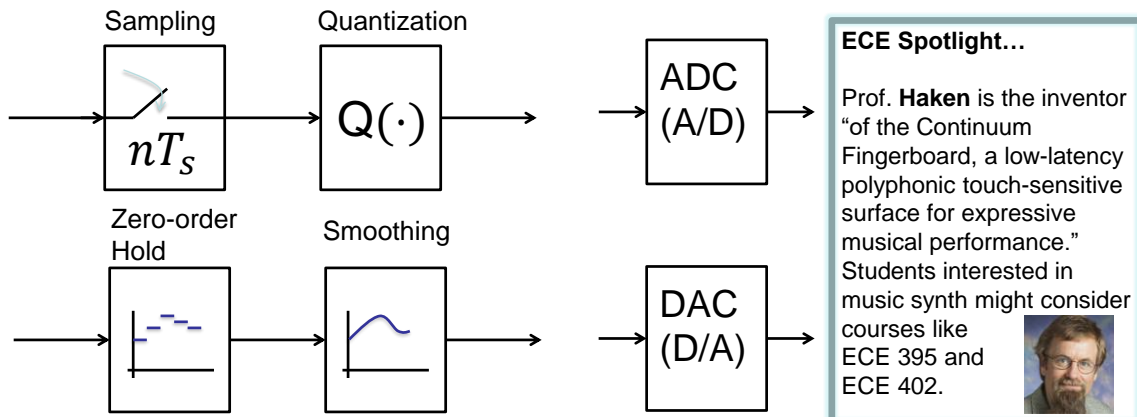

The zero-order hold results in an analog voltage. What circuit parts might a smoothing filter contain?

- A. Resistors B. Capacitors C. Diodes D. BJTs E. MOSFETs

290



Exercises

Q: CD-quality music is sampled at 44.1 kHz with a 16-bit quantizer. How much memory (in Bytes) is used to store 10 seconds of sampled-and-quantized data?

291



Exercises

Q: CD-quality music is sampled at 44.1 kHz with a 16-bit quantizer. It is stored on a 700 MB CD. How many minutes of music do you predict a single CD can hold? (Does your answer account for stereo?)

292



Exercises

Q: Digital voice mail samples at 8 kHz. 32 MB of memory is filled after 3200 seconds of recording. How many bits of resolution is the quantizer utilizing?

293



L26: Learning Objectives

- a. Convert a voltage series to a quantized (bit) representation
- b. Solve problems involving sampling rate, quantizer size, memory size, and acquisition time
- c. Find the Nyquist rate of a signal given its highest frequency
- d. To be able write out binary integers numbers in increasing value
- e. Describe the implications for sound quality based on sampling rate and quantization depth (# bits in quantizer)

294



Lecture 27: Content Personalization

More of what you want to know! Instructor will choose the content and learning objectives based largely on student surveys from early in the semester!

295



L27: Learning Objectives

- a. Both the content and learning objectives of this lecture will be determined by the instructors during the semester. They will use feedback provided by the students to tailor their choices.

296

Lecture 28: Photodiodes and Solar Panels

- The nature of light
- Photon absorption in semiconductors
- Photocurrent in diodes and its use
 - Detecting light and signals
 - Generating electrical energy
- Energy from solar panels

ECE Spotlight...

ECE Professor **Bayram** conducts research at the intersection of Novel III-V materials/hetero-structures and Photonic/electronic quantum devices. He teaches ECE 443: *LEDs and Solar Cells*

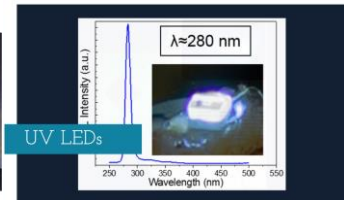

297

Light consists of (Energetic) Photons

- Photons are sometimes called wave packets
- Each photon (of wavelength λ in nm) carries an amount of energy

$$E = \frac{1240}{\lambda} \left[\frac{eV}{\text{photon}} \right]$$
 1 eV is equivalent to $1.6 \times 10^{-19} \text{ J}$
- The color of light depends on its wavelenath, λ

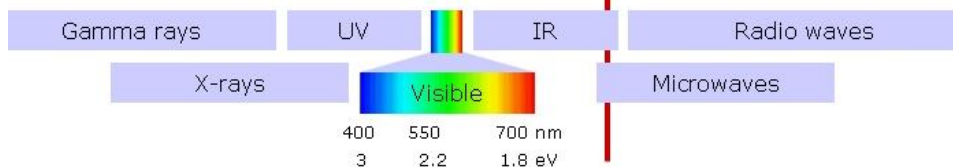

Q: How many photons per second are provided by a 1 mW 650 nm laser?

298

Available Solar Energy (Radiation Spectrum)

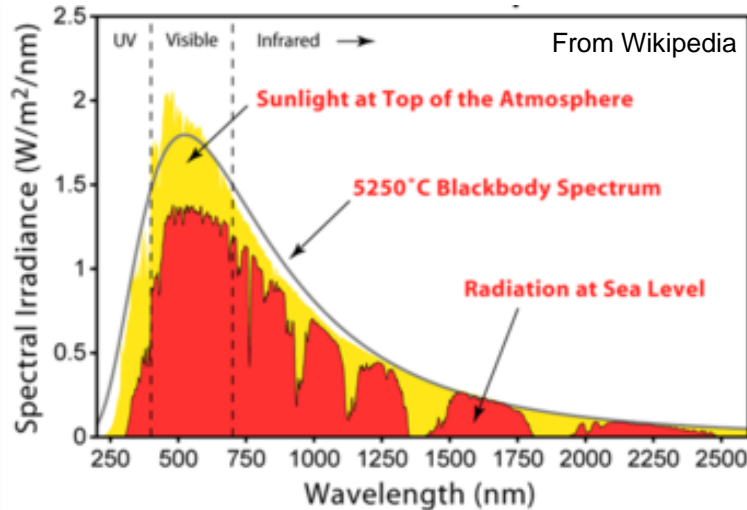

Pick the closest answer:

- A. 1 W/m²
- B. 10 W/m²
- C. 100 W/m²
- D. 1000 W/m²
- E. 10 kW/m²

Q: Estimate the solar irradiance (W/m²) at sea level (hint: total red area).

299

Creating electron-hole pairs in Semiconductors

- An electron in a material can absorb a photon's energy
- An electron can sometimes lose energy to emit a photon
- Semiconductor electrons have a gap in allowed energy, E_g
- Photons with energy bigger than the gap are absorbed
- Absorbed photons can create usable electrical energy

300

Exercises

Q: What is the maximum wavelength absorbed by:

Si ($E_g = 1.1 \text{ eV}$),

by GaN ($E_g = 3.4 \text{ eV}$),

and by diamond carbon ($E_g = 5.5 \text{ eV}$)?

301

Photodiode IV depends on impinging Light

- Reverse bias mode
 - Photodetector
 - Detecting light signals
 - Energy is dissipated
- Forward bias mode
 - Photovoltaic cell
 - Energy is generated

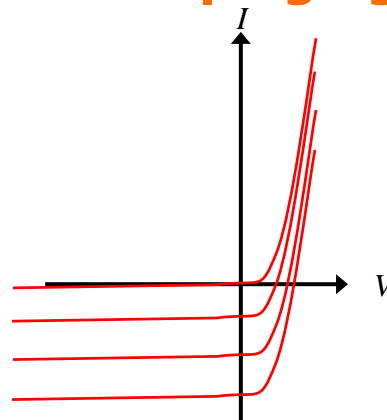

302

Exercise

Q: Sparkfun's BPW34 photodiode generates 50 μA of current when reverse-biased and illuminated with 1 mW/cm^2 at 950 nm. If a 1 mW 950 nm laser is focused on the photodetector, what is the resulting photocurrent?

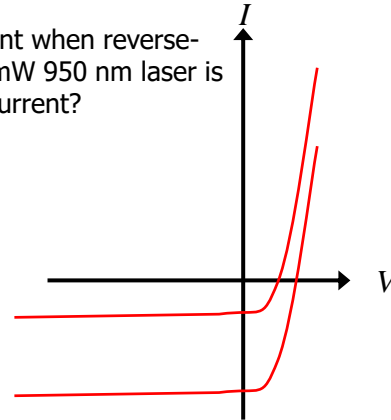

303

Photovoltaic operation collects Energy

- Forward-bias mode
- $P = IV$ is supplied
- Maximum power point
- $P_{max} = I_m V_m = FF I_{sc} V_{oc}$
- Typical FF = 70%

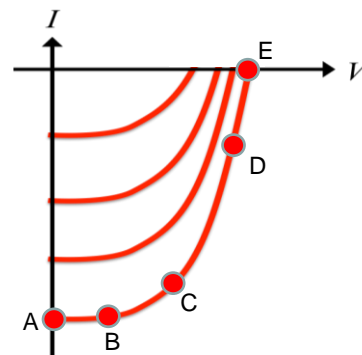

Q: Identify the P_{max} point above

Q: If Sparkfun's BPW34 photodiode has $I_{sc} = 40 \mu\text{A}$ and $V_{oc} = 350 \text{mV}$ when illuminated with 1 mW/cm^2 at 950 nm, and the fill factor is 50% what is the maximum power produced?

304



Solar panels as energy sources



Q: Assuming 500 W/m^2 solar irradiance and a 25% efficient solar panel, how much roof area should be covered to supply 50A at 120V?

Q: Given an average of 5 hours of sunshine per day and a utility cost of \$0.11/kWh how much of the utility cost can such a solar panel save?

ECE Spotlight...

ECEB is aspiring to a Net Zero Energy rating and targeting LEED Platinum certification from the U.S. Green Building Council. You should look into the project to learn how it is being achieved. Do some of your own number crunching!



305



Lecture 28 Learning Objectives

- Relate photon flux (photons/sec) to power and wavelength
- Calculate maximum absorbed wavelength for a band gap
- Sketch photodiode IV curve and explain operating regimes
- Calculate reverse bias current for incident light power
- Calculate maximum power from IV intercepts and fill factor
- Estimate power (and its \$ value) produced by a solar panel

306



Lecture 29: Course Review

- If you have a request that a specific question or topic be covered on this day, please email your instructor.
- Other questions will focus on *muddy points*.
- More info TBA.

307



308