

The Relaxation Oscillator

Laboratory Outline

In Lab 5, we constructed a simple three-element oscillator using a capacitor, resistor, and a Schmitt trigger inverter. It is a feedback system: the binary output of the inverter is at either the ground reference of 0 volts or at the supply voltage of 5 volts, causing the capacitor at the input to discharge or charge, respectively. The path for charging or discharging the capacitor is provided by a resistor, the value of which can be changed to alter the rate of the two events and, thereby, alter the operating frequency of the oscillator itself. In this module, we will generate circuit models for the charging and discharging events, separately, and present time-domain expressions for the voltage across the capacitor to solve for the frequency of oscillation. The models will provide you with a deeper understanding of feedback loops as you learn about relaxation-oscillator analysis.

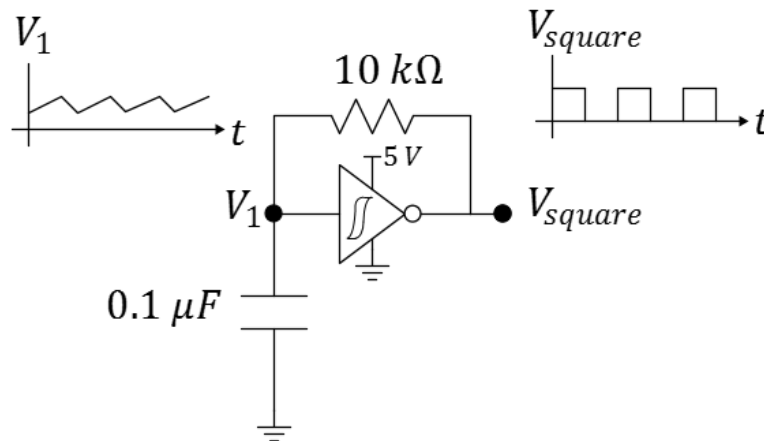

Figure 1: The relaxation oscillator of Laboratory Exercise #5.

Prerequisites

- Laboratory Exercise #5, the construction of a simple low-power oscillator circuit.
- Familiarity with diode circuits.

Parts Needed

- None. This is a reading exercise with some limited exposure to algebra and calculus.

From Wikipedia: [...] a **relaxation oscillator** is a nonlinear electronic oscillator that produces a non-sinusoidal output signal, such as a triangle or a square wave.

Our low-power oscillator from Lab 5 of ECE110 uses the non-linear Schmitt trigger (inverter) to produce both a triangular waveform (at the Schmitt trigger input) and a square waveform (at the Schmitt trigger output).

At Home: This entire exercise may be completed anywhere!

Schmitt Trigger Parameters

To understand the operation of the oscillator, we first need to understand the operation of the Schmitt trigger inverter. Find the datasheet for the CD40106 Schmitt Trigger Inverter. The datasheet will describe a hysteresis (a form of memory) within the device where the input/output relationship for changing input values will depend on the time history of the input. For example, if the input voltage V_{IN} starts at 0 volts (ground) and climbs, the output voltage V_{OUT} will remain high until the input voltage reaches the value V_p as demonstrated in Figure 2. At this point, the output voltage will drop to 0 volts. As the input voltage then falls back below V_p , the output voltage persists in staying low (0 volts) until finally the input falls below a value of V_n . This means that there is not a one-to-one relationship between V_{IN} and V_{OUT} like we are mostly accustomed to in previous math courses. This relationship is graphed in Figure 2. We consider V_p to be the positive-going threshold voltage and V_n to be the negative-going threshold voltage of the Schmitt Trigger.

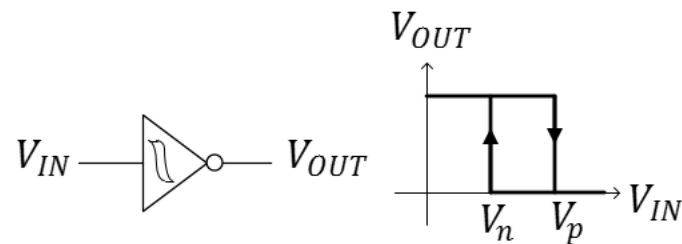

Figure 2: The input/output relationship of the Schmitt trigger from Texas Instruments, the TI 40106.

Question 1: Use the datasheet to argue that the positive-going threshold voltage may be given by $V_p \approx 0.4 V_{DD}$ for power supply voltages of V_{DD} between 5 and 10 volts.

Question 2: Use the datasheet to argue that the negative-going threshold voltage may be given by $V_n \approx 0.5 V_{DD}$ for power supply voltages of V_{DD} between 5 and 10 volts.

If you are curious, you can set up your own laboratory experiment to improve the approximations $V_p \approx 0.5 V_{DD}$ and $V_n \approx 0.4 V_{DD}$.

Capacitor Charging and Discharging

When a capacitor is charged by a constant (DC) voltage supply of V_{DD} , the time-domain voltage across the capacitor is given as

$$V_1(t) = (V_i - V_{DD}) \left(1 - e^{-\frac{t}{RC}}\right) + V_{DD}$$

where C is the capacitance being charged, V_i is the initial voltage on the capacitor at time $t = 0$, and R is the series resistance within the charging path. We say that the voltage is asymptotically approaching V_{DD} , although most of the charging occurs in a short time span on the order of the product R times C (often called the time constant). In Figure 3, initial voltage $V_i = 0$ volts.

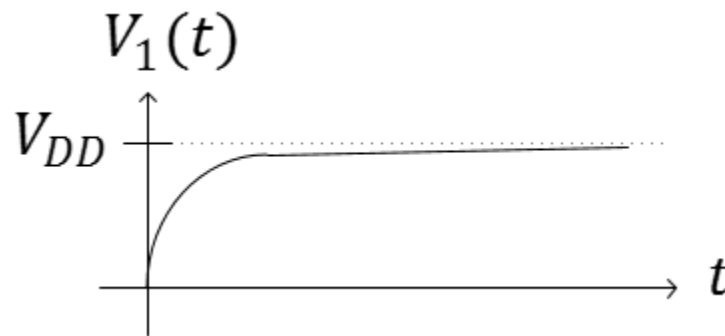

Figure 3: The waveform V_1 across a capacitor while charging to V_{DD} .

When a capacitor is being discharged to ground voltage (0 V), the time-domain voltage across the capacitor is given by

$$V_1(t) = V_{start} e^{-\frac{t}{RC}}$$

where we are assuming the voltage across the capacitor is V_{start} at the beginning of the discharge. As before, the decay of the capacitor to 0 volts follows an asymptotic path with much of the decay occurring in the order of magnitude of RC .

Equation Reference: ECE210 textbook, page 97, *Analogy Signals and Systems* by Kudeki and Munson.

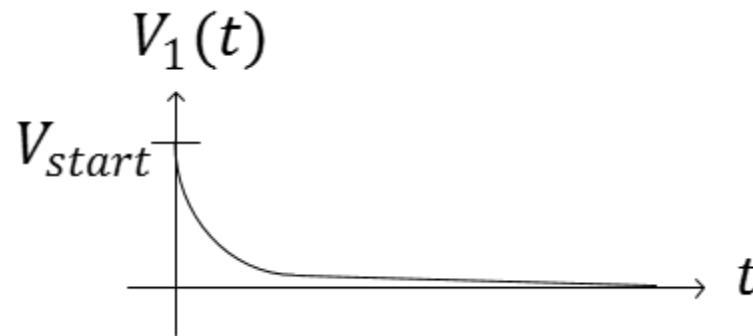

Figure 4: The waveform V_1 across a capacitor while discharging to ground voltage.

With this understanding, let's investigate what happens during the charging and discharging cycles of the capacitor within our oscillator.

The Relaxation Oscillator

The voltage across the capacitor in our working oscillator charges and discharges as would be expected with any capacitor. The difference lies in the fact that the capacitor is never allowed to fully charge or discharge due to a circuit feedback path.

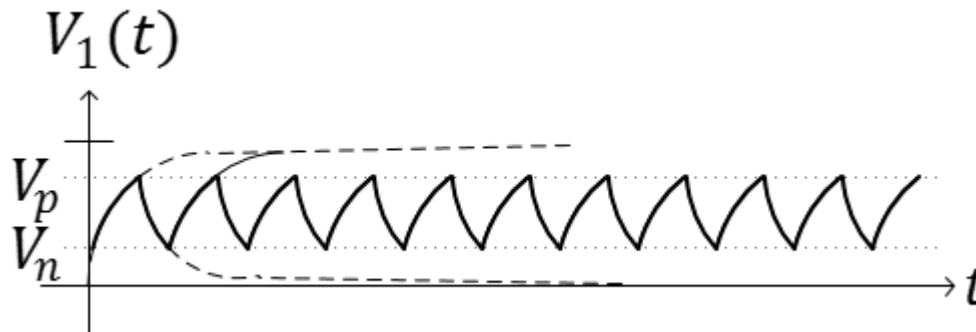

Figure 5: The waveform V_1 across the capacitor in our oscillator while in repetitive charging/discharging cycles. The switching of the Schmitt trigger's output results in the oscillatory behavior.

To explain why the capacitor never completely charges or discharges, we need to use a model for the inverter that allows us to simplify the circuit into something we are more familiar with. First, we make use of the fact that the input to the Schmitt trigger draws very little current. In fact, the current flowing into the Schmitt trigger is so small, we model it as an open circuit! This is true whether we are charging or discharging the capacitor.

For the output of the Schmitt trigger, we will need two models. 1) When the input voltage V_1 is small, the output of the Schmitt trigger is high (near V_{DD}). Therefore, for the charging cycle, the oscillator circuit can be modeled by Figure 6a. 2) When the input voltage is high, the Schmitt trigger output is high (near ground voltage, 0 V) and the oscillator circuit can be modelled by Figure 6b.

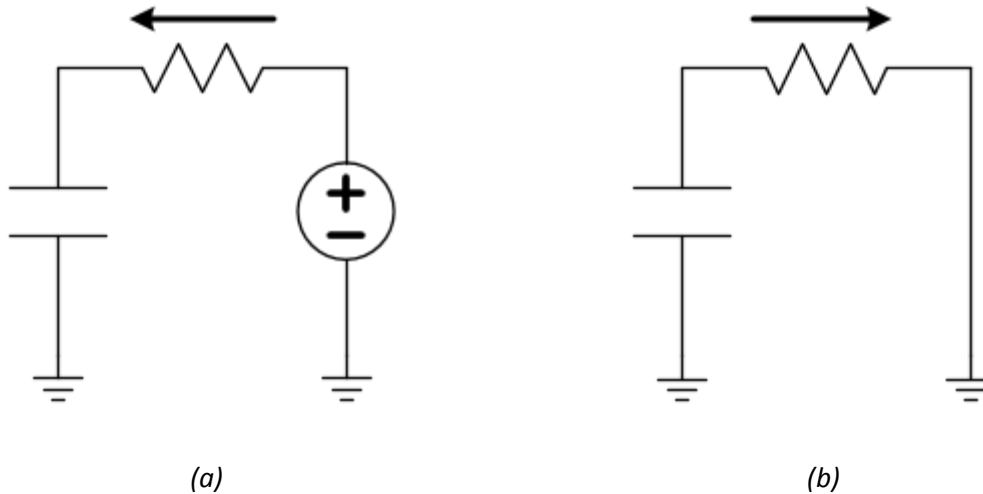

Figure 6: Charging (a) and discharging (b) schematics for the oscillator circuit after making modeling assumptions for the Schmitt trigger. The arrow shows the direction positive-valued current will flow as the capacitor charges and discharges, respectively.

During the charging cycle, the capacitor will asymptotically charging towards V_{DD} V. Of course, it will stop charging at the point that $V_1(t_2) = V_p$ (see Figure 7). We can compute the time required for the charge time $\Delta t = t_2 - t_1$, by substituting the correct parameters and solving the earlier equation for t_2 .

$$V_p = (V_n - V_{DD}) \left(1 - e^{-\frac{\Delta t}{RC}} \right) + V_{DD}$$

$$\frac{V_p - V_{DD}}{V_n - V_{DD}} = e^{-\frac{\Delta t}{RC}}$$

$$\ln \left(\frac{V_p - V_{DD}}{V_n - V_{DD}} \right) = -\frac{\Delta t}{RC}$$

$\ln(x)$ is the “natural log” of x .
We make use of the fact that
 $\ln(x) - \ln(y) = \ln \left(\frac{x}{y} \right)$.

$$t_{charge} = \Delta t = RC \ln \left(\frac{V_p - V_{DD}}{V_n - V_{DD}} \right) = RC \ln \left(\frac{V_{DD} - V_p}{V_{DD} - V_n} \right)$$

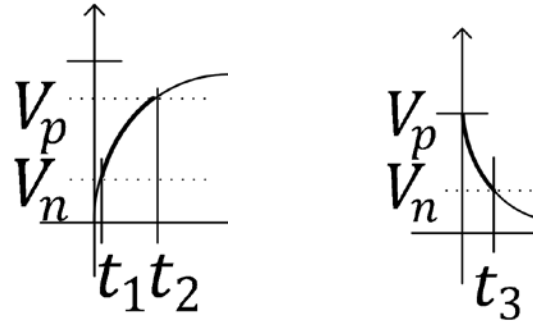

Figure 7: Focus on the charging and discharging intervals for a Schmitt-trigger-based oscillator.

The time required to discharge from V_p to V_n can be computed from $V_n = V_p e^{-\frac{t_3}{RC}}$:

$$t_{discharge} = t_3 = RC \ln \left(\frac{V_p}{V_n} \right)$$

Since the capacitor must both charge and discharge in every period of the oscillatory waveform, the period is given by

$$T = t_{charge} + t_{discharge} = RC \ln \left(\frac{(V_{DD} - V_n)V_p}{(V_{DD} - V_p)V_n} \right) = \ln \left(\frac{(1 - 0.4)0.5}{(1 - 0.5)0.4} \right) RC = \ln \left(\frac{0.6}{0.4} \right) RC = 0.41 RC$$

and the frequency of oscillation is given by

$$f = \frac{1}{T} = \frac{1}{0.41 RC}$$

Question 3: What happens to the frequency of oscillation when the capacitance is doubled? What happens to the frequency of oscillation when the resistance is doubled?

Drawing Conclusions

Question 4: *Think about it...* This analysis changes in Lab 8 when diodes are placed in the feedback and feedforward paths. Redraw the charging and discharging circuit schematics (similar to Figure 6) including a diode in the path for each. How do you think these diodes will affect t_{charge} and $t_{discharge}$?

Learning Objectives

- To apply capacitor charging and discharging formulas to the relaxation oscillator and estimate oscillatory frequency.
- To use circuit models to reduce a challenging problem to one that can be solved using basic circuit analysis.

Explore Even More!

The oscillator is a key component in ***Explore More! Module: The Voltage Comparator*** where we learn that the voltage V_1 must be protected by a “buffer” in order to be utilized in a Pulse-Width Modulation waveform generator. Eventually, the oscillator is a key component in the ***Explore More! Module: PWM Control via an Active Sensor***.