

The Clipping Circuit

Laboratory Outline

Keeping a time-varying voltage within bounds can be necessary for an engineering in many situations. For example, it is possible that an electronic device might be damaged by a applied voltage differential that exceeds a certain maximum rating. A simple circuit that provides such protection is called the clipping circuit or simply a “clipper.”

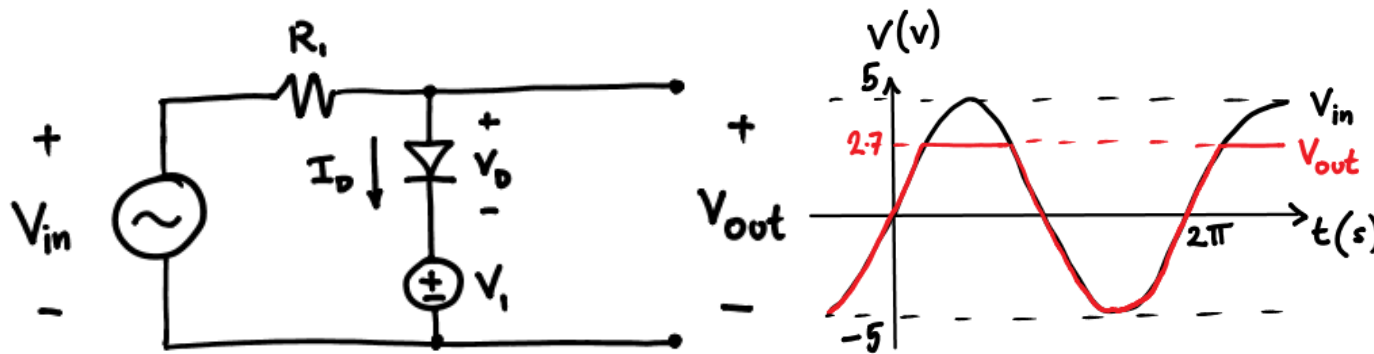

Figure 1: Diode clipper input and output. Example: We set the constant voltage source $V_1=2$ V. The input V_{in} is from Fig. 1. The output V_{out} , with $V_{on}=0.7$ V, is clipped to a maximum of $V_1+V_{on}=2.7$ V.

Prerequisites

- Laboratory Exercise #7, diodes.

Parts Needed

- Signal (smaller) diode and an LED (any color)
- Function generator, voltage supply, $330\ \Omega$ resistor, oscilloscope

In the Laboratory

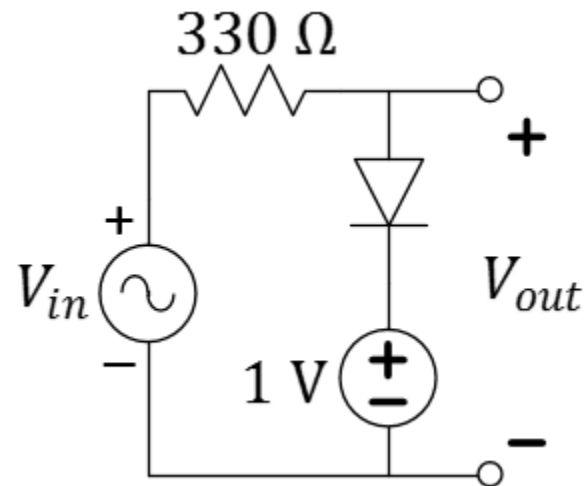

Figure 2: A diode clipper circuit.

Build the diode clipper circuit shown above. Let $V_{in} = A\cos(2\pi 200t)$ volts be produced by the function generator.

Question 1: Use the oscilloscope to capture V_{out} and V_{in} simultaneously. Change the amplitude A and observe. Plot them on the same graph in MATLAB for $A = 3\text{ V}$.

Question 2: Select a single point in time when $V_{in} \approx 2\text{ V}$ and use KVL to validate the value of V_{out} seen at that same point in time.

Question 3: Change V_{in} to a triangular waveform with the same amplitude $A = 3$. Plot V_{in} and V_{out} on the same graph in MATLAB.

Drawing Conclusions

Question 4: Replace your signal diode with the LED. Report below the color of your LED. Adjust the amplitude of your triangular waveform until the circuit just barely begins to clip. Explain in an equation how this value of A is related to V_1 (of Figure 1) and V_{on} of the diode. Estimate V_{on} . No plot is necessary.

Learning Objectives

- To gain experience the use of the function generator and the oscilloscope.
- To build and gain experience with the clipping circuit.
- To use empirical lab measurements to approximate a model value (V_{on}) for an LED.

Explore Even More!

The diode is used in the motor drive circuit. What does it do? Find out about the ill-effect that electromagnetic induction can have on a motor as it is started and stopped in the **Explore More! Protecting the Motor**.