

Name/NetID:

# Experiment 5: Time-Varying Circuits

Teammate/NetID:

## Laboratory Outline:

Last week, we analyzed simple circuits with constant voltages using the DC power supply and digital multimeter (DMM). This week, we'll learn to deal with voltages that vary over time by using the function generator and oscilloscope which can be found on your lab bench. Once this lab is complete, you'll understand *how* and *when* to use all the bench equipment in the ECE 110 Lab. Unless an experiment requires a particularly-obscure capability from these devices, all future procedures will assume you understand how to take the necessary measurements using the necessary sources and meters. In addition, you will have expanded your knowledge on constructing *prototype circuits* and will be able to build most circuits required of future experiments.

Section AB/BB:

0 1 2 3 4 5 6 7

8 9 A B C D E F

(circle one)

## Learning Objectives

- Identify the settings of a function generator and configure the generator for a specific signal.
- Use DC equipment to measure a time-varying signal and identify the shortcomings.
- Identify the settings of an oscilloscope and configure the oscilloscope with different settings.
- Use the oscilloscope to measure different signal types and self-identify optimal settings in each case.
- Only if time remains, complete the objectives of a self-selected **Explore More! Module**.

## Using the Oscilloscope and Function Generator:

In order to analyze voltages that vary with time, we must use *a measurement device that can capture a time history* of those voltages. This device is called an **oscilloscope**. In addition, there are many situations in which we might desire to *generate a specific periodic voltage* without having to build a special circuit to do so. We can do this using what is called a **function generator** (sometimes called a *signal generator* or *waveform generator*, although these titles can imply different operations). Once we have mastered the use of this bench equipment, we'll continue to hone our equipment knowledge for the rest of the semester through practical use.

### Think about it...

Signals that are “nearly” periodic occur around us every day. The buzz of the honeybee, vibrations of a car engine, and sunlight hitting a solar panel all contain measurable signals that show repetition. What periodic signals can you think of? How might those signals be measured electronically? What engineering solution might come from having that kind of information?

# Function Generator

A function generator is a piece of equipment that outputs an electrical voltage waveform that can vary in time, in contrast to the DC power supply that can only output a constant voltage. The output waveform of our function generator is periodic. The waveform's shape can be chosen from a predetermined "function" list. Besides the waveform's shape, the front panel buttons allow the user to alter other parameters of the waveform like frequency, amplitude, offset, and duty cycle.

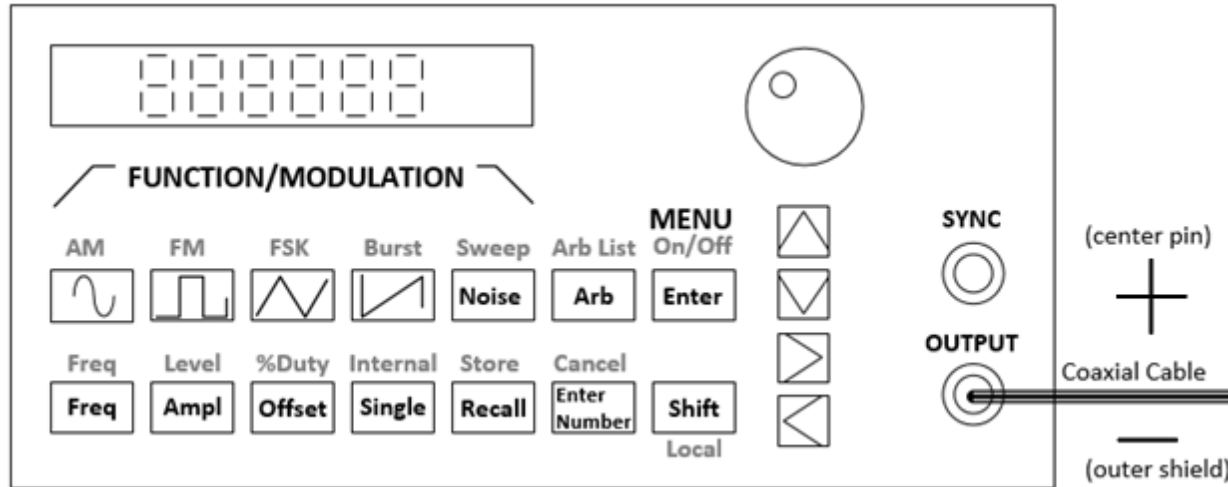

**Figure 1:** The front panel of the HP33120A function generator. At the BNC output, the center pin is the positive voltage reference while the outer shield is the negative (often the "ground" reference).

The waveform output is generated inside the device from functions stored in memory in digital form. The list of binary numbers that specify the waveform are applied to a Digital-to-Analog (D/A) converter and output as an analog waveform through the bottommost BNC connector that is labeled OUTPUT. The diagram shows the front panel of the function generator along with instructions on how to set up the device to output a sine wave with a specific frequency and amplitude. The circuit symbols for several different functions are provided in **Figure 2**.

The SYNC port is used to synchronize the "clocks" of multiple devices. We will not use it in ECE110. Be careful not to accidentally confuse it with the OUTPUT port.

Notes:

**Important!** The function generator may be modeled as an ideal source plus a series resistance of  $50\ \Omega$ . If you are measuring with a device that has high input resistance (the voltmeter has very high resistance and the oscilloscope is generally set to  $1\ M\Omega$ ), then the measuring device will show nearly the voltage of the ideal source (as per the voltage divider rule). If you want the displayed value of the function generator's to match the voltage read by a high-resistance device, you need to set the function generator to "High Z". Do this by pressing this series of keys on the function generator: **Shift, Enter, >, >, >, V,V,>,Enter**. The function generator will now show the voltage value of the "ideal internal source". *You must do this each time you use the function generator.*

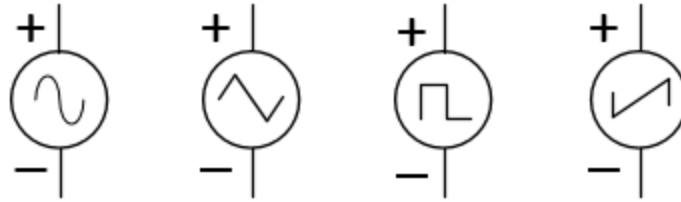

**Figure 2:** Circuit symbols for the sine, triangular, square, and sawtooth waveforms, respectively.

Setup the Function Generator (HP33120A) to output a sine wave with a frequency of 1000 Hz, a 4 V peak-to-peak amplitude, and an offset of 0 V.

Set the following parameters of the output by pressing the corresponding button and turning the large knob if necessary.

- ✓ **Function** – press the button on the function generator that shows a **sine wave**.
- ✓ **Amplitude** – Press the *Ampl* button. This shows you the default amplitude value in the display. To quickly change the amplitude, turn the dial in the upper right corner. Alternately, fine tuning can be accomplished by pressing the up/down arrows. Either control changes the digit blinking on the display. A different digit can be made to blink by using the left/right arrow keys.
- ✓ **Frequency** – Press the *Freq* button. Adjust settings with the dial or arrows.
- ✓ **Offset** – Press the *Offset* button. Adjust settings with the dial or arrows.
- ✓ Connect the output port of the function generator to the **voltmeter** using a BNC-to-banana cable. Warning: The *sync* output contains a periodic signal, but not the one you are designing! It is easy to accidentally connect to the wrong port!

**Question 1:** Draw a circuit schematic of your setup including the function generator and the DMM being sure to mark the polarity of each device.

**Question 2:** Measure the DC voltage and record it here. Discuss what information this single measurement provides regarding the waveform you generated. Does it provide a complete view? Explain.

Notes:

For **Question 1**, use these circuit symbols:

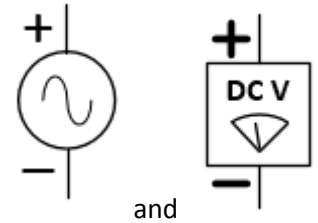

# Oscilloscope

The oscilloscope (often called an “o-scope” or “scope” for short) is a measurement device that can capture a time history of a signal. Reference the prelab for details of its operation including the horizontal settings, the vertical settings, and, most importantly, the triggering mechanism. Recall that we assumed the trigger occurs when the signal rises across the trigger set point, but can be configured to trigger on a falling edge. We will see a reason for doing this later today.

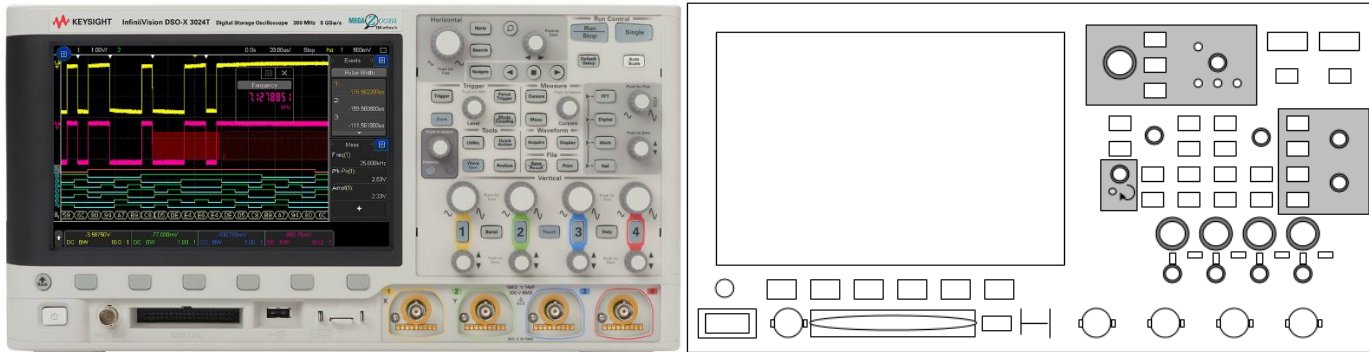

**Figure 3:** A photo of the KEYSIGHT oscilloscope and our physical model of it.

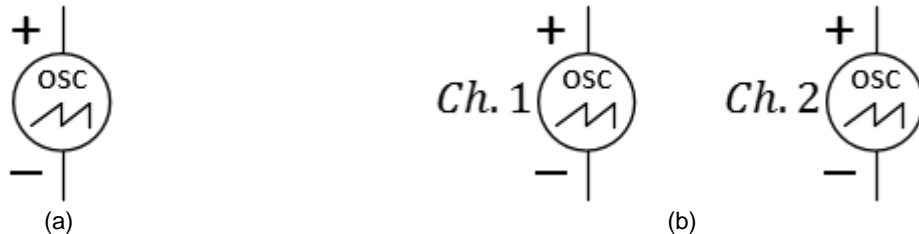

**Figure 4:** Circuit schematic symbol for an oscilloscope (a). For two channels, repeat the symbol and label each as show in (b). Note that the text “osc” eliminates ambiguity between this symbol and that of a sawtooth voltage source.

Setup the oscilloscope **and** the voltmeter to both probe the voltage delivered by the function generator.

- ✓ Connect the output port of the function generator to channel 1 of the oscilloscope as well as the voltmeter.
- ✓ Play with the oscilloscope knobs to adjust the horizontal (Time/div) and the vertical (Volts/div) resolution.

- ✓ Set the vertical resolution to 1 V/div and the horizontal resolution so that *at least* 1 period of the signal is clearly displayed.
- ✓ If the display appears to be “untriggered”, try turning the triggering threshold knob, first counter-clockwise. If you continue to have trouble, don’t worry. The next section will help you straighten it out!

**Question 3:** Draw a circuit schematic of your setup including the function generator, the DMM, and the oscilloscope.

**Question 4:** Measure the peak-to-peak voltage and the period as seen on the oscilloscope display by eye and record them here. Are they close to the settings you chose on the function generator?

Last week, we took extensive measurements of DC circuits using the DMM. While the DMM is the preferred device for DC circuits, the oscilloscope actually has the capability of reading any signal and internally computing the average voltage (that is, it can also provide the DMM measurement in addition to the time-domain signal). To access this ability, press the button **Meas** in the **Measure** group of buttons in the center of the oscilloscope. Using the keys underneath the screen, press the one that says **Type: xx**, and a menu will popup. Use your finger to double-click **Average—N cycles**. The oscilloscope will then display its estimate of the average voltage.

Notes:

For **Question 3**, use these circuit symbols:

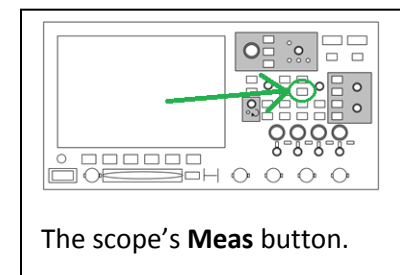
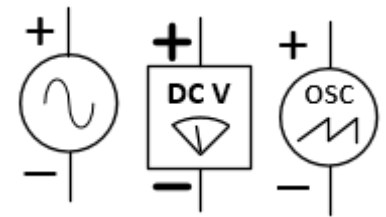

The scope’s **Meas** button.

Measure the average voltage, peak-to-peak amplitude, and the frequency using the oscilloscope.

- ✓ Press the **Meas** button in the **Measure** group of buttons on the oscilloscope.
- ✓ Using the buttons below the screen, press the one that says **TYPE:xx**, and a menu will popup.
- ✓ Select **Average-N cycles**.
- ✓ The measured average voltage should now appear on the oscilloscope display.
- ✓ Repeat this process and select **Peak-Peak** instead of average.
- ✓ Repeat this process once more and select **Frequency**.
- ✓ You should now be able to see all three measurements on the display.

**Question 5:** Record your three measurements here. Are they different from the values you specified on the function generator?

**Note:** If you desire to measure a signal that is NOT periodic, it can be difficult to view using an oscilloscope. In many situations, you would use the oscilloscope to capture a single frame that can be stored using the store commands (we will cover that later). Can you see why an aperiodic signal would be difficult to view using the oscilloscope? As a special case, voltage signals carrying data symbols (like two different voltages representing logical ones and zeroes) *can* be triggered in a useful manner (for example, the edges of the symbols can be easily identified).

## Offset measurements (AC and DC Coupling)

Another parameter that you can control using the function generator is the offset of the function. In the figure below there are plots of a periodic signal called a square wave. The functional description of the periodic signal pictured in the leftmost plot,  $y(t)$ ,

can be generated by replicating the signal  $v(t) = \begin{cases} -2, & -\frac{T}{2} < t \leq 0 \\ +2, & 0 < t \leq T/2 \\ 0, & \text{otherwise} \end{cases}$  at intervals of  $T$ . The signal in the rightmost plot can be

obtained from  $y(t)$  by adding a constant value the signal at all times to give  $p(t) = 2 + y(t)$ . This constant is called the offset.

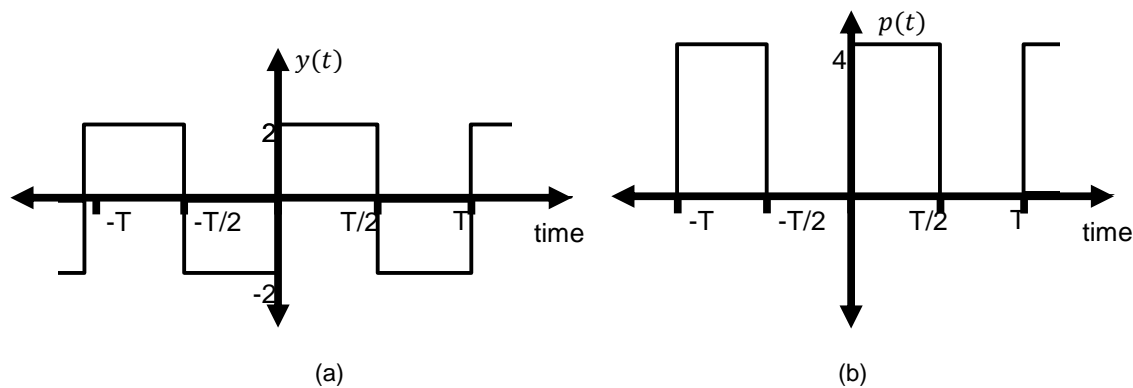

**Figure 5:** A periodic square wave (a) and the same signal offset by a constant  $+2$  V (b).

⇒ Setup Function Generator to output an *offset sine wave* (not a square wave) with a frequency of 1000 Hz, a 4 V peak-to-peak amplitude, and an offset of 2 V.

- ✓ Without disconnecting any circuitry, press the offset button on the function generator and turn the knob until 2 V is specified.
- ✓ Press the glowing green button labelled "1" on the oscilloscope (assuming you are using channel 1 of the scope).
- ✓ Press the button labelled COUPLING in the menu at the bottom of the screen.
- ✓ Verify that the oscilloscope is configured to DC COUPLING by repeatedly pressing the same button if necessary.



Notes:

**Question 6:** Plot the sine wave as it should appear **with the offset** on the graph paper provided in the appendix. (If using MATLAB for automated data collection, save your MATLAB data and code as you will add another plot soon.) Call this Figure 7.

**Question 7:** Describe in words how the waveform changes when you change the offset.

**Question 8:** With the offset still turned **on**, switch the oscilloscope's channel 1 coupling from DC coupling to AC coupling. Overlay this plot with the previous plot (or MATLAB graph). For the two curves consider using a different type of line, or a different color, or simply label each curve so that a person reading your lab report would know which graph represents a sine wave with, and without an offset.

**Question 9:** How did the display change? What is the effect of the AC coupling setting?

There is a software called **KeySight BenchVue** on your computer that can be used to export scope data to MATLAB. Your TA can point you to the instructions.

## Duty Cycle Measurements

For a square wave, you can specify a parameter called **duty cycle**. You will be able to define duty cycle when you have completed this section.

⇒ Setup Function Generator to output an *offset square wave* with a frequency of 1000 Hz, a 4 V peak-to-peak amplitude, and an offset of 2 V.

- ✓ Make sure the oscilloscope is in DC coupling mode.
- ✓ Without disconnecting any circuitry, set the function generator to output a square wave.
- ✓ When asked to do so, change the duty cycle from 50% (which is the default) to another value of your choice.

**Question 10:** Using another sheet of graph paper provided in the appendix, draw a square wave with the default duty cycle of 50%. Alternately, use MATLAB to control the oscilloscope, collect the data, and produce the plot.

**Question 11:** Set the function generator to a different duty cycle (of your choosing). Superimpose a plot of a square wave with your chosen duty cycle over the previous plot.

**Question 12:** The **duty cycle** is *the percentage of time that the signal is greater than zero*. On the oscilloscope, measure the duty cycle by eye by counting the intervals in the horizontal direction between the leading and falling edges of the pulse and then comparing that value to the period. Record your measurements below.

**Question 13:** Use the **Meas** button on the oscilloscope choosing the positive duty cycle measurement (instead of average and amplitude) to get the oscilloscope's estimate of the duty cycle. Record it here.

To change duty cycle on the function generator, press:  
**Shift, Offset** (% Duty).

### Think about it...

Controlling/changing the duty cycle of a square wave is a technique called pulse-width modulation and is used in robotic control, digitization of signals, and communication of data. We will use PWM quite a bit in the ECE110 laboratory!

## Exploring Trace Triggering

The sinusoidal signal you analyzed earlier is very useful in helping learn the basics of the trigger, but you will likely encounter many other waveforms in future laboratories and research. Without a broader understanding of the oscilloscope's trigger, you may find yourself at a loss to understand how to set up an experiment. In this section, using the oscilloscope to measure a sawtooth waveform will help us further understand the physical operation of the trigger.

⇒ Setup the oscilloscope to investigate triggering by inputting a sawtooth waveform with a frequency of 1 kHz, 2 V peak-to-peak, and no offset from the function generator.

- ✓ Press the **Trigger** button found in the **Trigger** section on the oscilloscope. Set the triggering source to be channel 1. Making this selection means that the signal input to channel 1 determines how the oscilloscope redraws the signal each time.
- ✓ Adjust the triggering level using the trigger **Level** knob. You will see a horizontal line appear on the scope - this line moves up and down as you turn the **Level** knob. The position of this line tells the oscilloscope to start redrawing the signal when the value of the function reaches the value specified by this horizontal line ON THE RISING EDGE of the function.

**Question 14:** On a third sheet of graph paper, draw the sawtooth wave displayed on the oscilloscope along with a horizontal line indicating the trigger level (or collect using MATLAB). Don't forget to use good techniques in plotting. We suggest, among other things, that you circle all the intersections of the trigger level with the sawtooth wave on the RISING EDGE (the portion of the function that is increasing) of the waveform and add a title/caption to your graph.

- ✓ Change the settings so that the oscilloscope triggers using the FALLING EDGE of the function instead of the RISING EDGE. This can be changed by pressing the **Slope** "soft key" on the oscilloscope. Configure for the **(Falling)** trigger.

**Question 15:** Now that the triggering will occur on the FALLING EDGE of the waveform (the portion of the waveform that is decreasing), adjust the trigger level again and make observations. Plot this on another sheet of graph paper (or use MATLAB).

**Question 16:** Why do you not see a change in the appearance of the display when the level is changed now?

(Hint: Expand the time scale so that you can see what the sawtooth looks like during the sharp drop in voltage from the positive peak to the negative peak. A time-per-division setting of  $1 \mu s$  should do it. This is the 'falling edge' that you are using to set the trigger level. How does the form of the falling edge differ from that of the rising edge?)

**Question 17:** Let's see what happens when the scope is not well triggered. Keep the sawtooth wave connected to channel 1, but now set the triggering source to be channel 2 which has nothing connected to it. What has happened to the display? Why? Press the  $\frac{Run}{Stop}$  button as you consider your answer.

✓ You may disassemble your circuit.

## Conclusion

In today's lab, we spent a significant amount of time honing our skills with the oscilloscope. While this is partially due to the fact that the oscilloscope is a complicated device, it also indicates that knowing how to use it is highly important. At the start of the lab we built a circuit that produced a time-varying voltage and discovered that the DMM fell short of producing useful measurements. Although the DMM is convenient and relatively simple to use, it is often inadequate for dealing with time varying signals. If we want to analyze a time varying signal, we must know how to use an oscilloscope.

Now that we have learned the basics of using the DMM and Oscilloscope to make measurements and extract information about a circuit, the rest of the semester will be a chance to practice using them. Next time when you are looking for answers about the functionality or output of a device or you are concerned with a potential bug in your circuit or coding, turn on the DMM or oscilloscope and TRY TO FIND IT OUT YOURSELF.

**Question 18:** Explain how the DMM is not enough to analyze waveforms in this lab.

**Question 19:** Discuss how the oscilloscope operates to display recent portions of a periodic signal in a human-readable format, that is, discuss the triggering operation.

**Question 20:** (optional,...if you have time remaining) Use the oscilloscope to view the output of your microphone circuit built in the prelab. Try tapping, talking, and whistling into the microphone. Describe your methods and observations here.

## What You Learned

You should now understand *how* and *when* to use all the bench equipment in the ECE 110 Lab. Unless an experiment requires a particularly-obscure capability from these devices, all future procedures will assume you understand how to take the necessary measurements using the necessary sources and meters. In addition, you have expanded your knowledge on constructing prototype circuits and will be able to build most circuits required of future experiments.

## Explore More!

At the end of each regular lab procedure, as time permits, you will be provided with materials to continue to improve your mastery of the materials. The suggested modules for this week are the ***Explore More! Lissajous Figures*** and ***Explore More! Measurements of Time-Varying Signals***. You are to work on these as long as time permits.

**Don't cheat yourself!** (Most) labs have been written in a way to finish early and allow you to experience the cool and diverse stuff in the ***Explore More!*** modules. We apologize that this particular laboratory exercise may run long, but the oscilloscope is a very important tool for electronics.

## Lab Report Rubric

The following rubric will be provided at the end of each lab procedure. As a final step in preparing your lab report, you will use this rubric to analyze your own performance.

Section	Criterion	Comments:
<i>Experimental Setup and/or Design Description</i>	Circuit Schematics are drawn neatly, accurately, and properly labeled. Decisions regarding experimental setup and design are clearly explained.	
<i>Measurements</i>	Tables include units and proper precision. Any <i>new device</i> introduced should be characterized using measurements!	
<i>Computations</i>	Computations performed on raw data are <i>explicitly</i> described and follow rules for significant figures.	
<i>Analysis</i>	Graphs have title, labels, units, scale, legend; Lines for curve-fitting appear in the graph when needed and parameters like the intercepts and the slope are labeled.	
<i>Modeling</i>	A mathematical model for the curve-fit graph allows for more abstract references to the device's behavior. The expected behavior is explained in the context of the graph.	
<i>Conclusion</i>	Conclusions are drawn from your experimental results to support the reason(s) for completing the experiment. Closes the loop on the Introduction.	
<i>General Formatting</i>	Answers to questions clearly labeled. The overall appearance of the report is professional.	
<i>Self-assessment</i>	This table has been thoughtfully completed.	