

Name/NetID:

# Experiment #3: Experimenting with Resistor Circuits

---

Teammate/NetID:

## Laboratory Outline

During the semester, the lecture will provide some of the mathematical underpinnings of circuit theory. The laboratory will help you apply common these fundamental circuit concepts and mathematical abstractions to interconnected physical devices. You will witness conditions in which the simple mathematical descriptions break down for real-world devices.

In this lab, you will experiment with resistor networks (different configurations of resistors) to determine their behavior. You will reinforce DC measurement skills and experiment with the mathematical relationships between the voltages and currents in the circuits.

All electrical engineers speak a common language that they use to communicate ideas and design specifications. Perhaps most importantly, in this lab you will gain practice using a critical design-sharing visual language – the schematic.

*Please use the Notes margin on the right for both notes to yourself about the experiment as well as for feedback to your TA on the quality or clarity of the lab procedure. Thanks!*

## Learning Objectives

- Construct series and parallel combinations of resistors. Measure and record equivalent resistance.
- Record measurements of voltages and currents in series and parallel circuits. Use the data to conclude relationships between currents, voltages, and resistances in the two configurations.
- Create a circuit schematic that represents a real physical circuit.
- Witness how “sub-circuit” parameters are different depending on your point of reference.
- Complete the objectives of an **Explore More! Module** self-selected by the student.

Section AB/BB:

0 1 2 3 4 5 6 7

8 9 A B C D E F

(circle one)

## Common resistor Connections – Series and Parallel Connections

Your instructor may have discussed two common ways to connect resistors in a circuit – *series* and in *parallel*. Two resistors in series share a common node with each other, but no other circuit elements. A series string of resistors divides the voltage across the group proportionally to each resistor's value. A parallel combination of resistors allows loops to be drawn that contain only those two resistors and no other elements. A group of parallel resistors provides paths that divide the current flowing into the group inverse-proportionally to each resistor's value. In the following examples, you are simultaneously exposed to the math, the schematic, and the physical layout of many resistor networks. Voltage measurements will enable you to understand basic relationships between the observed device behavior and the mathematical relations presented in lecture.

### Series Connection

A series connection is a resistor network where the same *current* flows through each device. Let's build a simple series circuit.

- ✓ Build the circuit from the schematic of Figure 1 using  $R_1 = R_2 = 1\text{ k}\Omega$ . The voltage  $V_S$  will be provided by the power supply you used last week – but **DO NOT HOOK UP THE POWER YET**. The + and – signs indicate the proper polarity of the power supply when you eventually hook it up.

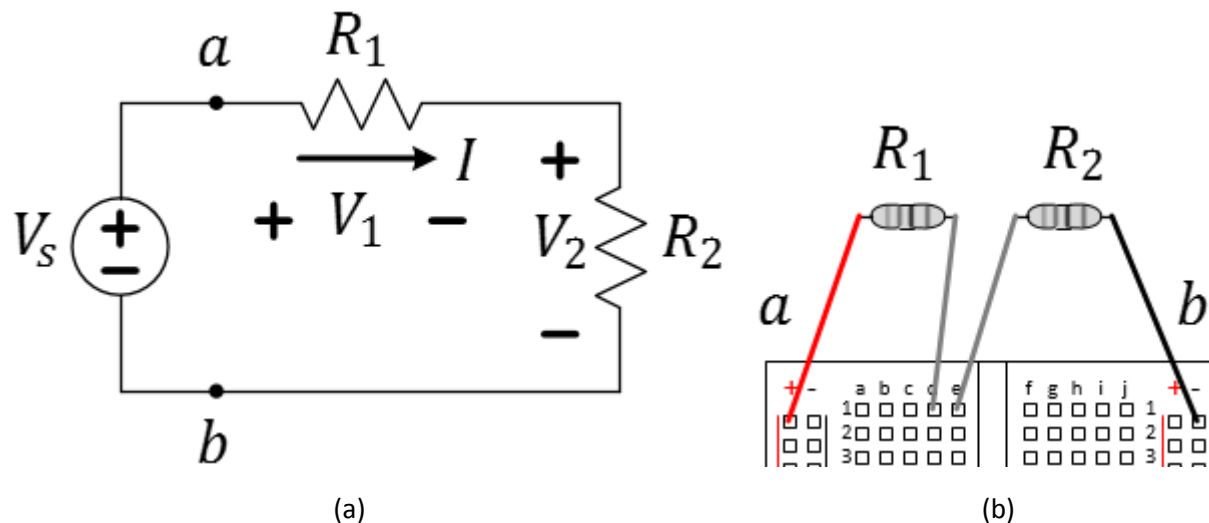

**Figure 1:** A series network of resistors; (a) the schematic and (b) a physical diagram without the power supply.

**In later labs**, devices like the diode, transistor, and other integrated circuits will require critical attention to the power polarity for the desired operation to occur.

### Parallel Connection

A parallel connection applied to a resistor network is one where the same *voltage* appears across each device.

- ✓ Now build the parallel resistor network shown below somewhere else on your breadboard. Do not remove your series circuit. Again, start with  $R_1 = R_2 = 1\text{ k}\Omega$ , and, again, do not connect the power source yet.

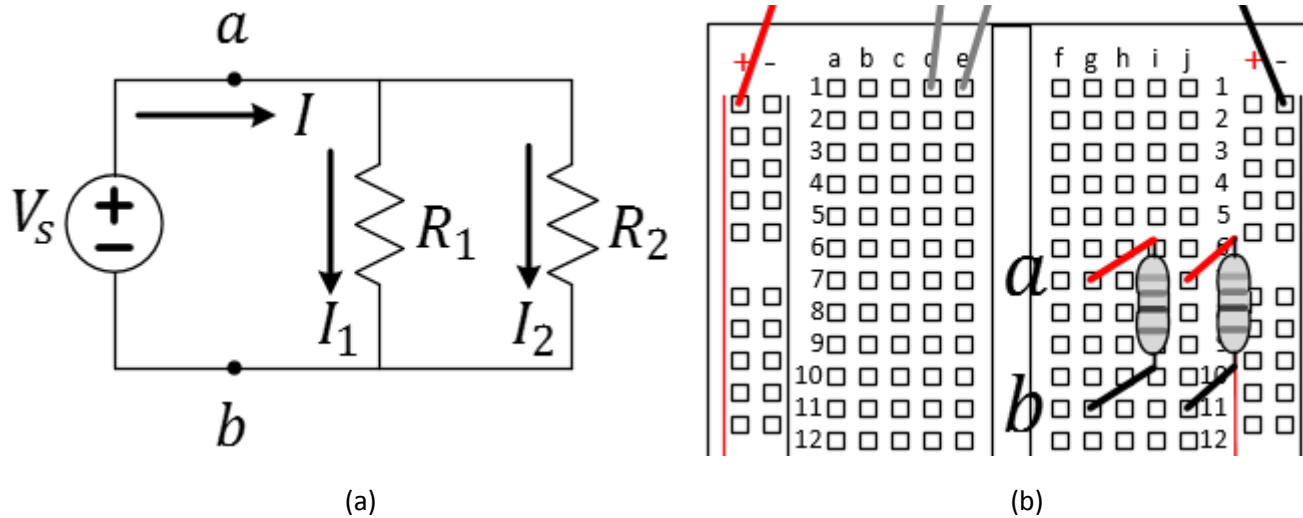

**Figure 2:** A parallel network of resistors; (a) the schematic and (b) a physical diagram without the power supply.

**Question 1:** Measure the resistance of the resistor network, both series and parallel, by probing the circuit between the corresponding points “a” and “b” and record the values. In lecture, you will call this value the equivalent resistance  $R_{eq}$ . NOTE: The power supply must be disconnected to get a proper resistance measurement – this is why you were instructed to keep the power supply disconnected at first.

$R_{eq} =$  (Series)

$R_{eq} =$  (Parallel)

Measure these resistance values without the power source!

**Question 2:** Explain why we could not use the same physical location for nodes **a** and **b** for the two different resistor networks. (Think of how it would have affected the measurements of the two equivalent resistances.)

- ✓ Finally, connect the power supply and set it to 5 V.
- ✓ Set up one of the DMMs to measure the value of  $I$ , the current that flows directly out of the power supply and labeled on the schematic above.

**Question 3:** Measure the current  $I$  in both circuits.

$$I = \quad \text{(Series)}$$

$$I = \quad \text{(Parallel)}$$

**Question 4:** Assume that the linear expression of Ohm's Law applies to  $V_S$ ,  $R_{eq}$ , and  $I$ . Calculate  $R_{eq}$  from  $V$  and  $I$  and compare it to the earlier values measured using the Ohmmeter.

- ✓ Remove the ammeter from the circuit.

The next three questions examine the relationship of the voltages across resistors connected in *series*.

**Question 5:** Use the DMM to measure the voltage across each resistor in the series circuit and record the results in first empty row of the table below. Be sure to include the values of the resistors and the corresponding voltages. Experiment with changing the resistor values  $R_1$  and  $R_2$  ( $R_1$  need not equal  $R_2$ ) to complete the table. After every change, measure the equivalent resistance  $R_{eq}$  before connecting the power supply to the resistors. Record  $R_{eq}$  value and the voltages across each resistor for each row of the table. PLEASE: Always choose values  $> 1\text{ k}\Omega$  to limit the power consumed by the resistors. In one of your resistor choices select resistor values that are orders of magnitude different – for example, one resistor might be  $1\text{ k}\Omega$  and the other  $1\text{ M}\Omega$ . Also, for at least one choice of resistors, record two rows of data where the supply voltage,  $V_S$ , is varied instead.

$V_S$ (in volts)	$R_1$ ( $\Omega$ )	$R_2$ ( $\Omega$ )	$V_1$ (in volts)	$V_2$ (in volts)	$R_{eq}$ ( $\Omega$ )
5	1 k $\Omega$	1 k $\Omega$			
5					
5					
5					
5					
5					
5					
5					
5					

Table 1. Enter your caption here!

**Question 6:** Discuss the trend between the voltages across each resistor and the relative resistance values for this series network. Pay attention to the next question as you draft your response.

**Question 7:** Using the data in the table, find a relationship between  $V_1$  and  $V_S$  that utilizes  $R_1$  and  $R_{eq}$ .

The next three questions examine the relationship of the currents passing through resistors connected in *parallel*.

- ✓ Configure your bench to determine the currents  $I_1$  and  $I_2$  in **one of two ways**:
  - Use the two DMMs as ammeters. This is a great way to gain experience in using the ammeter. If you choose to do this method, have the TA check your connections to reduce the possibility of blowing a fuse (which is OK!), but have the TA check your circuit to minimize the risk.
  - Measure  $V_1$  and  $V_2$  then use Ohm's Law to compute the currents since  $I = V/R$  and the resistance values are known.

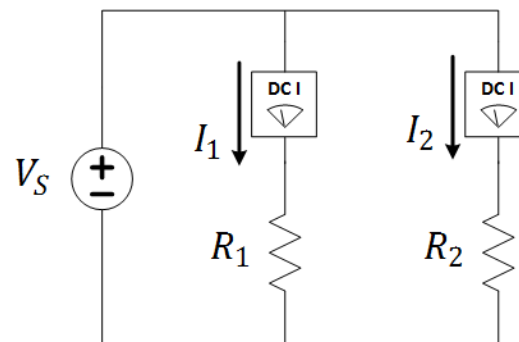

**Figure 3:** The ammeter must be in series with the element whose current is measured.

Notes:

**Question 8:** Either measure or compute the currents  $I_1$  and  $I_2$  for the initial configuration where  $V_S = 5\text{ V}$  and both resistors are  $1\text{ k}\Omega$  and enter the values in the table below. Continue to experiment with changing the resistor values. Choose values  $> 1\text{ k}\Omega$  if you are *measuring* the currents. Measure or compute these currents and record the values in the same table. As with the series configuration, choose a couple resistor combinations that vary over orders of magnitude. You do not need to vary the source voltage.

$V_S$ (in volts)	$R_1$ ( $\Omega$ )	$R_2$	$I_1$	$I_2$	$R_{eq}$
5					
5					
5					
5					
5					
5					
5					
5					

**Table 2.** *Enter your caption here!*

**Question 9:** Discuss the trend between the voltages across each resistor and the relative resistance values for this parallel network. Pay attention to the next question as you draft your response.

**Question 10:** Using the data in the table, find a relationship between  $I_1$  and  $V_S$  that utilizes  $R_1$ ,  $R_2$  and/or  $R_{eq}$ . To see how  $I_1$  relates to the total current flowing from the source,  $\frac{V_S}{R_{eq}}$ , re-write your solution in the form below. Find  $K$  in terms of  $R_1$ ,  $R_2$  and/or  $R_{eq}$ .  $I_1 = K \frac{V_S}{R_{eq}}$ ,  $K =$  \_\_\_\_\_

### Reverse Engineering

To help develop skills necessary for “prototyping” a design and the ability to build any circuit from a schematic there is nothing like trying to reverse engineer someone else’s circuit.

- ✓ Build a rat’s nest of a circuit made up of only resistors. Connect it to the power and ground rails of the breadboard, but do not connect it to a power supply.
- ✓ Give the circuit to your partner or anyone else in your lab section. They must convert your circuit into a schematic so a few ground rules.
  - The configuration must conduct between 1 and 500 mA of current when connected to a power supply of 5 V.
  - Do not include intentional mistakes...that is nothing tricky like breaking a wire and hiding the fact that it is broken.
  - Unless the person you give the circuit to wants a challenge, use no more than 8 resistors.
  - You may build the resistor network in such a way as to obscure the connectivity – be creative.

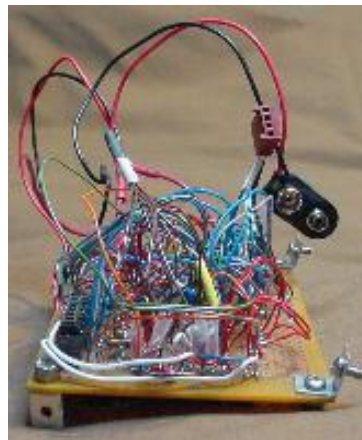

**Figure 4:** Example of the rat’s nest approach to connectivity. *Image ref:* [www.robotroom.com](http://www.robotroom.com)



**Question 11:** Draw the schematic of the circuit given to you by another laboratory student. If (unintentional) errors exist, either identify the error (as a challenge) or give it back and ask the person who constructed the network to fix it. For example, it is common to have two devices not connected because the person building the circuit missed the proper hole on the breadboard.

### *Resistor/Source Connectivity*

In this portion of the lab, you will see that equivalent resistance and circuit behavior depend on your reference point (the nodes are you accessing for your measurement or applying a power source).

- ✓ Build the resistor network circuit using the schematic below using  $R_1 = 1\text{ k}\Omega$ ,  $R_2 = 2.2\text{ k}\Omega$ , and  $R_3 = 3.3\text{ k}\Omega$ . Do not connect the circuit to the power supply yet.

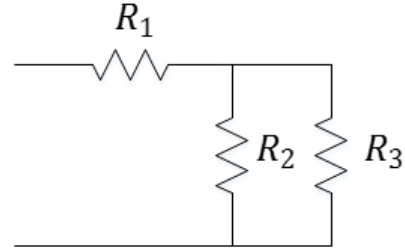

**Figure 5:** A slightly more complex resistor network.

**Question 12:** Measure the equivalent resistance of Figure 5 (relative to the left side) and record the value.

- ✓ Now add the power supply to the circuit set to  $V_S = 5\text{ V}$ .

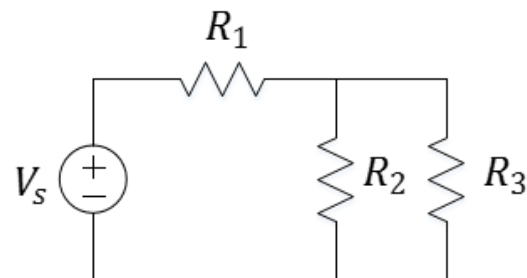

**Figure 6:** Adding power to the previous network.

**Question 13:** Measure the voltages across each resistor and record them directly on the schematic in Figure 6, including the polarity (+ and - signs) by which they were measured.

- ✓ Disconnect the power supply and reconfigure the resistor connections as shown in the figure below using the same three resistors.

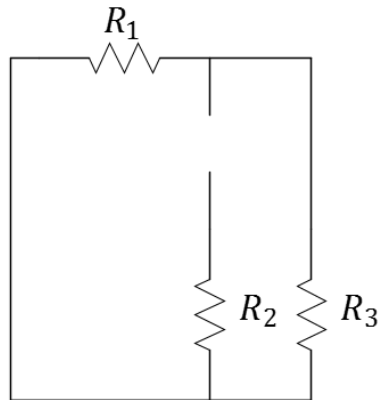

**Figure 7:** The same resistive network from a new “perspective”.

**Question 14:** Measure the equivalent resistance of this modified resistor configuration using the Ohmmeter and record the value here.

- ✓ Now add the power supply into the circuit set again to  $V_s = 5\text{ V}$ .

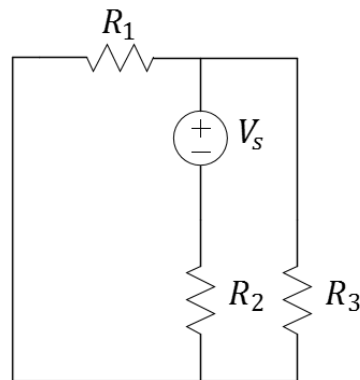

**Figure 8:** Adding power to the previous network.

**Question 15:** Measure the voltages across each resistor and record them on the schematic above, including the polarity by which they were measured.

**Question 16:** Did the voltages across each resistor remain the same or change when the location of the power supply changed? Discuss.

## What You Learned

This lab encouraged you to extend your skills in taking measurements and mapping each schematic – a visual representation of a circuit – to a physical circuit. The measurements demonstrate that, for simple resistor circuits, the relationships between the voltages and currents are linear. This is to establish an intuition placing the circuit laws in context. Finally, you witnessed that parameters associated with a given “sub-circuit” can differ depending on where and how you intend to build on to that circuit.

## Explore More!

At the end of each regular lab procedure, as time permits, you will be provided with materials to continue to improve your mastery of the materials. The suggested modules for this lab will be provided by the TA. You are to work on these as long as time permits. The modules will be submitted to your TA when finished. Completion of eight modules will count in your final grade.

Recommended module for today: ***Explore More! Making Resistors.***

Notes:

---

## Lab Report Rubric

The following rubric will be provided at the end of each lab procedure. As a final step in preparing your lab report, you will use this rubric to analyze your own performance.

Section	Criterion	Comments:
<i>Experimental Setup and/or Design Description</i>	Circuit Schematics are drawn neatly, accurately, and properly labeled. Decisions regarding experimental setup and design are clearly explained.	
<i>Measurements</i>	Tables include units and proper precision. Any <i>new device</i> introduced should be characterized using measurements!	
<i>Computations</i>	Computations performed on raw data are <i>explicitly</i> described and follow rules for significant figures.	
<i>Analysis</i>	Graphs have title, labels, units, scale, legend; Lines for curve-fitting appear in the graph when needed and parameters like the intercepts and the slope are labeled.	
<i>Modeling</i>	A mathematical model for the curve-fit graph allows for more abstract references to the device's behavior. The expected behavior is explained in the context of the graph.	
<i>Conclusion</i>	Conclusions are drawn from your experimental results to support the reason(s) for completing the experiment. Closes the loop on the Introduction.	
<i>General Formatting</i>	Answers to questions clearly labeled. The overall appearance of the report is professional.	
<i>Self-assessment</i>	This table has been thoughtfully completed.	