

Name/NetID:

# Pre-Lab 10: Control and Navigation

Teammate/NetID:

## Control Theory

Control is an engineering sub-discipline defined as “that branch [...] which deals with the design, identification and analysis of systems with a view towards controlling them, i. e., to make them perform specific tasks or make them behave in a desired way” (Control theory. (n.d.) Webster's Revised Unabridged Dictionary. (1913). Retrieved July 8 2014 from <http://www.thefreedictionary.com/Control+theory>).

Section AB/BB:

0 1 2 3 4 5 6 7

8 9 A B C D E F

(circle one)

Figure 1 shows the abstracted diagram of a generic control system. This generic version of a control system involves a reference, a measure of error, a *controller*, and a device (“plant”) to be controlled, all connected in a negative-feedback “control loop”.

The **reference** is a guide indicating where we want the plant to reside. For a satellite, the reference might be a pre-determined trajectory. For an airplane’s autopilot, the reference might be the plane’s altitude. The **error** is a measure of the difference between your reference and the actual position of the plant. We can assume (in a linear system) that small errors will require small adjustments and large errors will require large adjustments. The error will typically have a sign that suggests which direction the adjustment should be made. If the airplane is too high, it should reduce height; if too low, increase height. If the feedback was accidentally made to be “positive”, an airplane might pitch suddenly upward or crash into the ground! “Negative feedback” is the term given to a system configured in a way that attempts to take corrective action. The **controller** might be a simple gain adjustment, a filter, a microcontroller, or something else.

In your wall-avoiding vehicle design the reference is a path followed by the vehicle given the constraints that the vehicle must remain close to the wall. The device that measures the deviation or error from the reference path is the flex sensor. The plant is your vehicle, and the negative feedback circuit is the oscillator circuit you built. The resistance changes when the flex sensor is bent as it touches the wall. The duty cycle of the square wave signal is changed in response, thereby changing the speed of the motors so that the vehicle moves away from the wall.

The wall-avoiding car can be modelled by a feedback system with a simple multiplicative gain factor (see Figure 2). Such systems use only a single parameter to describe how aggressively the control system attempts to make a correction. This parameter is called the **gain factor** often designated  $K$ .

Consider a water reservoir control system. The goal is to keep the water level in the reservoir near an ideal level – this is the system’s reference point. A system of devices monitor the water level providing information to a feedback system – this

provides the error measurement. There is a pump that is used to control the water level – this is the plant. A feedback system modifies the water level– this is the controller. The flow rate is the system gain  $K$ . It is very important to choose  $K$  properly. For example, suppose the level of the reservoir is a little low. If the system’s pump suddenly begins dumping 1000 gallons per minute *into* the reservoir, the water level may be higher than the reference before the pumps can stop. Then it might then start dumping water *out* at too fast of a rate to compensate and end up at a level even lower than at the start! A large “loop gain”,  $K$ , can lead to instability when we consider the time it takes for a system to respond. A loop gain that is too small might result in an input water flow that cannot even compensate for typical water usage. Reducing the water flow in the previous example would be akin to reducing the gain factor  $K$ .

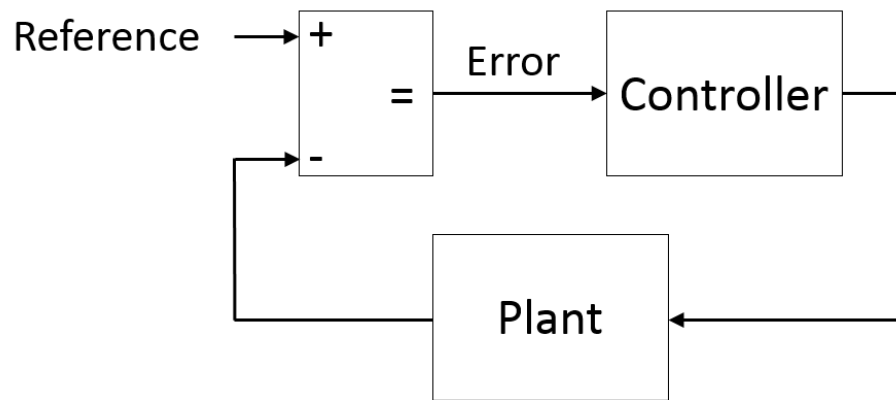

Figure 1: A generic control system involves a reference, a measure of error, a system “controller”, and a device (“plant”) to be controlled, all connected in a negative-feedback “control loop”.

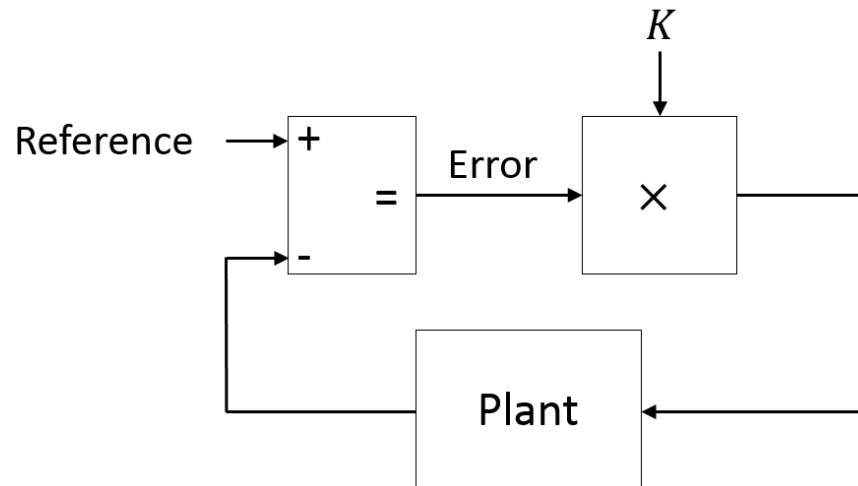

Figure 2: The simplest control system involves a reference, a measure of error, gain within the loop, and a device (“plant”) to be controlled. This is called “Proportional Control”.

While the generic control system is a valuable mathematical tool for analysis of a control-system design, it remains a rather vague task for the newcomer to properly identify how their physical system relates to the parameters defined in Figure 1. Today’s procedure will help guide you in making these identifications.

In our tasks today, the system to be controlled is a small robotic vehicle. Specifically, we are controlling the motors (the “plant”) that drive its wheels. For the first task, we will provide the design procedure. For the second task, you will imitate the design procedure to complete your own individualized design! To be successful, you will need to identify the operating characteristics of the devices involved, primarily the sensors and the motors. Some of these devices were already investigated in previous laboratory experiments, however, you will need to do your own characterization of any new components introduced into your system.

**Question 1:** Using input from the flex sensors on their vehicles Nick and Tommy design their feedback systems and choose a value of  $K$  by choosing values of the resistor  $R_1$  (the flex sensor) and  $R_2$  and capacitance  $C$  to choose a value for gain  $K$ . Suppose Nick designs his system to use a PWM range of 40-60% duty cycle to control his wheel speed. Tommy uses a PWM range of 80-100% to control his wheel speed. Who is likely to have a *more stable* control system? Why? (Just give heuristic justification)

**Question 2:** Discuss how the choices of the values of resistor  $R_1$  and  $R_2$  and capacitance  $C$  control the feedback gain. Remember that the flex sensor has a range of resistances depending on how much it is flexed.

## The Engineering Design Algorithm

When an engineer takes on the task of designing a new device, he or she will inherently follow a number of procedures that highlight their skills as effective problem solvers. These skills have been summarized and are often referred to as the steps of engineering design or, more formally, the Engineering Design Algorithm. We will adapt the version given by Orsak, et. al., in the textbook, *Engineering Our Digital Future: The Infinity Project*.

The Engineering Design Algorithm:

1. Evaluate the challenge by defining goals and constraints
2. Research the problem to design possible solutions
3. Choose the best solution from the options and build a prototype
4. Test and evaluate the prototype and return to earlier steps as needed

Notes:

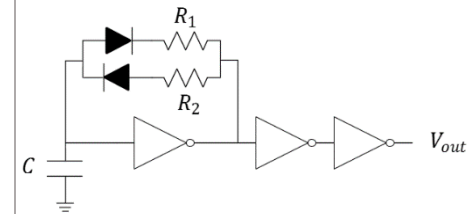

Notes:

---

Watch this interesting video about the design of the modern-day coffee maker and then answer the questions that follow.

<http://www.engineerguy.com/videos/video-coffee-maker.htm>

**Question 3:** Name at least two constraints of a good coffee maker and explain how they add to the challenge of designing one.

**Question 4:** Hypothesize about what problems the inventor of the coffee maker may have encountered and what he/she may have had to do to overcome them.