

# The Relaxation Oscillator

## Outline

Earlier, we constructed a simple three-element oscillator using a capacitor, resistor, and a Schmitt trigger inverter. It is a feedback system: the binary output of the inverter is at either the ground reference of 0 volts or at the supply voltage of 5 volts, causing the capacitor at the input to discharge or charge, respectively. The path for charging or discharging the capacitor is provided by a resistor, the value of which can be changed to alter the rate of the two events and, thereby, alter the operating frequency of the oscillator itself. In this module, we will generate circuit models for the charging and discharging events, separately, and present time-domain expressions for the voltage across the capacitor to solve for the frequency of oscillation. The models will provide you with a deeper understanding of feedback loops as you learn about relaxation-oscillator analysis.

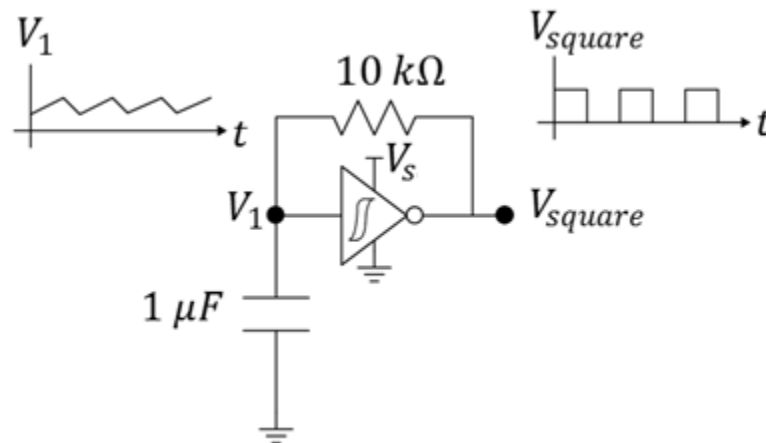

Figure 1: The relaxation oscillator.

## Prerequisites

- The experience of the construction of a simple low-power oscillator circuit.
- Familiarity with diode circuits.
- Some limited exposure to algebra and calculus.

From Wikipedia: [...] a **relaxation oscillator** is a nonlinear electronic oscillator that produces a non-sinusoidal output signal, such as a triangle or a square wave.

Our low-power oscillator from an earlier lab of ECE110 uses the non-linear Schmitt trigger (inverter) to produce both a triangular waveform (at the Schmitt trigger input) and a square wave (at the Schmitt trigger output).

## Parts Needed

- Inverting Schmitt trigger (CD40106 or similar)
- Potentiometer (2 k $\Omega$  or larger)
- Capacitor (10  $\mu F$ , substitution okay)
- Resistor (100 k $\Omega$ , substitution okay)
- Battery or other power source and breadboard.
- Oscilloscope

## Learning Objectives

- To use circuit models to reduce a challenging problem to one that can be solved using basic circuit analysis. See Figure 6.
- To apply capacitor charging and discharging formulas to the relaxation oscillator and estimate oscillatory frequency.
- To compare experimental data to theoretical predictions and hypothesize on the causes of any differences.

## Explore Related Materials

The oscillator produces a square wave output, but the voltage across the capacitor at its input is a nearly triangular pulse. To extract it for use (to drive a circuit that needs a triangular waveform) the voltage  $V_1$  must be protected by a “buffer.” We have an exercise available for this activity.

## Derivation of Oscillator Frequency

### Schmitt Trigger Parameters

To understand the operation of the oscillator, we first need to understand the operation of the Schmitt trigger inverter. Find the datasheet for the CD40106 Schmitt Trigger Inverter. The datasheet will describe a hysteresis (a form of memory) within the device where the input/output relationship for changing input values will depend on the time history of the input. For example, if the input voltage  $V_{IN}$  starts at 0 volts (ground) and climbs, the output voltage  $V_{OUT}$  will remain high until the input voltage reaches the value  $V_p$  as demonstrated in Figure 2. At this point, the output voltage will drop to 0 volts. As the input voltage then falls back below  $V_p$ , the output voltage persists in staying low (0 volts) until finally the input falls below a value of  $V_n$ . This means that there is not a one-to-one relationship between  $V_{IN}$  and  $V_{OUT}$  like we are mostly accustomed to in previous math courses. This relationship is graphed in Figure 2. We consider  $V_p$  to be the positive-going threshold voltage and  $V_n$  to be the negative-going threshold voltage of the Schmitt Trigger.

To find a datasheet, it typically works to enter the part number and the word “datasheet” into a search engine. Example: use Google’s search on “**TI CD 40106 datasheet**” to find the datasheet for TI’s Schmitt-Trigger Inverter.

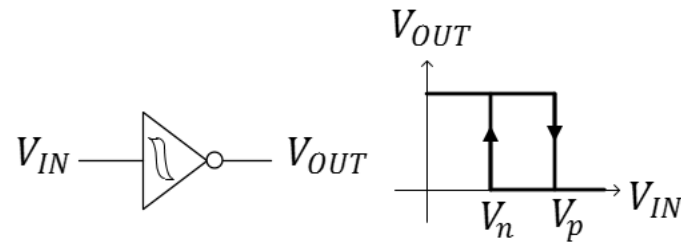

**Figure 2:** The input/output relationship of the Schmitt trigger from Texas Instruments, the TI 40106.

### Capacitor Charging and Discharging

When a capacitor is charged by a constant (DC) voltage supply of  $V_{DD}$ , the time-domain voltage across the capacitor is given as

$$V_1(t) = (V_i - V_{DD}) \left( e^{-\frac{t}{RC}} \right) + V_{DD}$$

where  $C$  is the capacitance being charged,  $V_i$  is the initial voltage on the capacitor at time  $t = 0$ , and  $R$  is the series resistance within the charging path. We say that the voltage is asymptotically approaching  $V_{DD}$ , although most of the charging occurs in a short time span on the order of the product  $R$  times  $C$  (often called the time constant). In Figure 3, initial voltage  $V_i = 0$  volts.

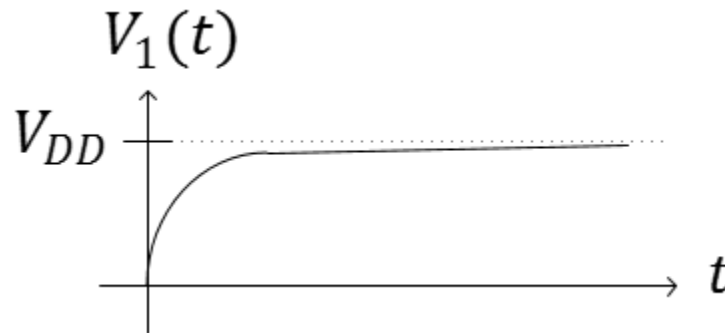

**Figure 3:** The waveform  $V_1$  across a capacitor while charging to  $V_{DD}$ .

When a capacitor is being discharged to ground voltage (0 V), the time-domain voltage across the capacitor is given by

$$V_1(t) = V_{start} e^{-\frac{t}{RC}}$$

**Equation Reference:** ECE210 textbook, page 97, *Analog Signals and Systems* by Kudeki and Munson.

where we are assuming the voltage across the capacitor is  $V_{start}$  at the beginning of the discharge. As before, the decay of the capacitor to 0 volts follows an asymptotic path with much of the decay occurring in the order of magnitude of  $RC$ .

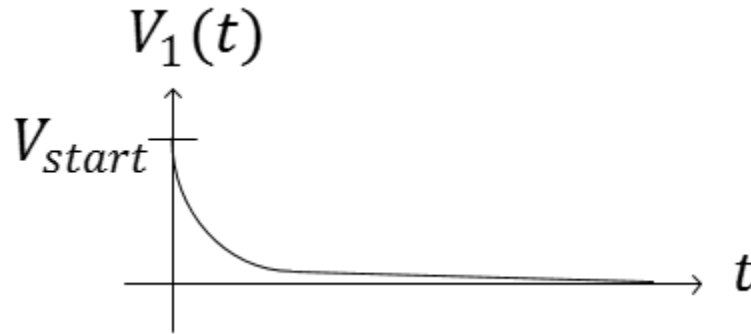
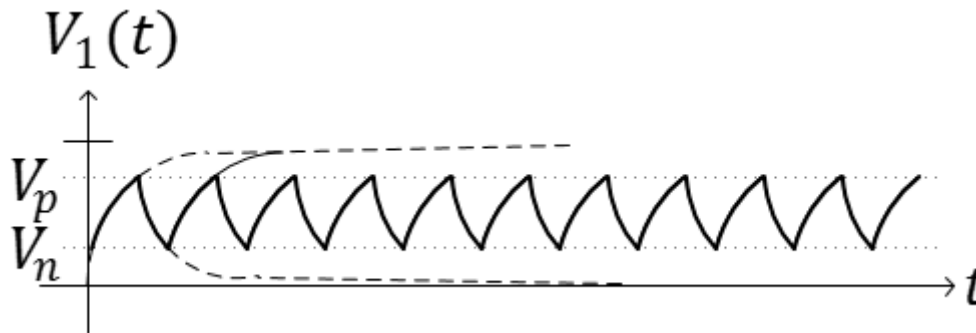

**Figure 4:** The waveform  $V_1$  across a capacitor while discharging to ground voltage.

With this understanding, let's investigate what happens during the charging and discharging cycles of the capacitor within our oscillator.

#### The Relaxation Oscillator

The voltage across the capacitor in our working oscillator charges and discharges as would be expected with any capacitor. The difference lies in the fact that the capacitor is never allowed to fully charge or discharge due to a circuit feedback path.



**Figure 5:** The waveform  $V_1$  across the capacitor in our oscillator while in repetitive charging/discharging cycles. The switching of the Schmitt trigger's output results in the oscillatory behavior. (The dashed lines demonstrate the charging and discharging cycles if the Schmitt trigger wouldn't have switched its output.)

To explain why the capacitor never completely charges or discharges, we need to use a model for the inverter that allows us to simplify the circuit into something we are more familiar with. First, we make use of the fact that the input to the Schmitt trigger draws very little current. In fact, the current flowing into the Schmitt trigger is so small, we model it as an open circuit! This is true whether we are charging or discharging the capacitor.

For the output of the Schmitt trigger, we will need two models. 1) When the input voltage  $V_1$  is small, the output of the Schmitt trigger is high (near  $V_{DD}$ ). Therefore, for the charging cycle, the oscillator circuit can be modeled by Figure 6a. 2) When the input voltage is high, the Schmitt trigger output is low (near ground voltage, 0 V) and the oscillator circuit can be modelled by Figure 6b.

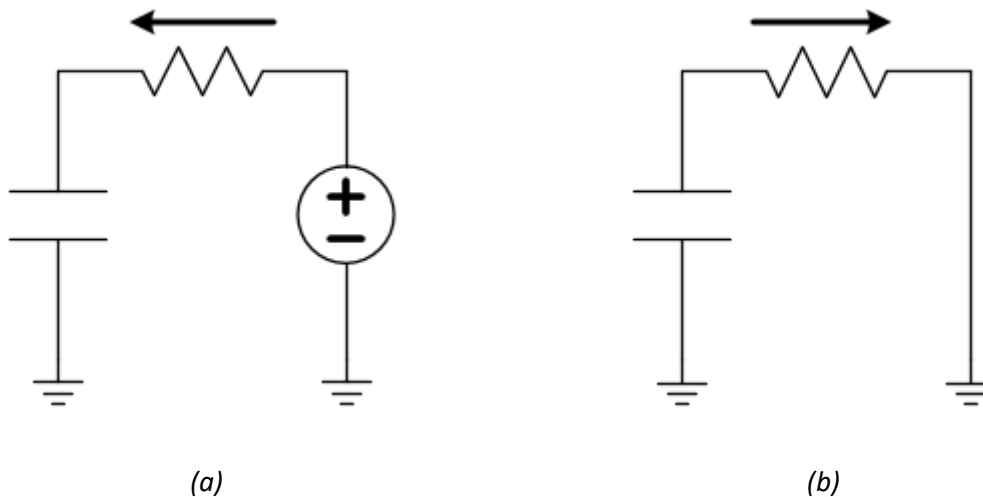

**Figure 6:** Charging (a) and discharging (b) schematics for the oscillator circuit after making modeling assumptions for the Schmitt trigger. The arrow shows the direction positive-valued current will flow as the capacitor charges and discharges, respectively.

During the charging cycle, the capacitor will asymptotically charge towards  $V_{DD}$  V. Of course, it will stop charging at the point that  $V_1(t_2) = V_p$  (see Figure 7). We can compute the time required for the charge time  $\Delta t = t_2 - t_1$ , by substituting the correct parameters and solving the earlier equation for  $t_2$ .

$$V_p = (V_n - V_{DD}) \left( e^{-\frac{\Delta t}{RC}} \right) + V_{DD}$$

$$\frac{V_p - V_{DD}}{V_n - V_{DD}} = e^{-\frac{\Delta t}{RC}}$$

$\ln(x)$  is the “natural log” of  $x$ . We often make use of the fact that  $\ln(x) - \ln(y) = \ln\left(\frac{x}{y}\right)$  or that  $-\ln(y) = \ln\left(\frac{1}{y}\right)$ .

$$\ln\left(\frac{V_p - V_{DD}}{V_n - V_{DD}}\right) = -\frac{\Delta t}{RC}$$

$$t_{charge} = \Delta t = -RC \ln\left(\frac{V_p - V_{DD}}{V_n - V_{DD}}\right) = -RC \ln\left(\frac{V_{DD} - V_p}{V_{DD} - V_n}\right) = +RC \ln\left(\frac{V_{DD} - V_n}{V_{DD} - V_p}\right)$$

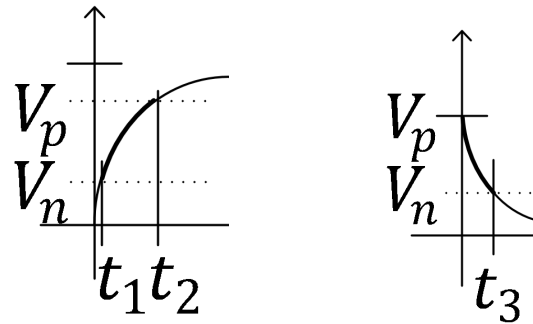

**Figure 7:** Focus on the charging and discharging intervals for a Schmitt-trigger-based oscillator.

The time required to discharge from  $V_p$  to  $V_n$  can be computed from  $V_n = V_p e^{-\frac{t_3}{RC}}$ :

$$t_{discharge} = t_3 = RC \ln\left(\frac{V_p}{V_n}\right)$$

Since the capacitor must both charge and discharge in every period of the oscillatory waveform, the period is given by

$$T = t_{charge} + t_{discharge} = RC \ln\left(\frac{(V_{DD} - V_n)V_p}{(V_{DD} - V_p)V_n}\right) = \ln\left(\frac{(1 - 0.4)0.6}{(1 - 0.6)0.4}\right) RC = 2 \times \ln\left(\frac{0.6}{0.4}\right) RC = 0.81 RC$$

and the frequency of oscillation is given by

$$f = \frac{1}{T} = \frac{1}{0.81 RC}$$

Name: \_\_\_\_\_

UIN:

--	--	--	--	--	--	--	--	--	--

Section AB/BB:

--

# The Relaxation Oscillator

---

**Question 1:** Use the datasheet to argue that the positive-going threshold voltage may be given by  $V_p \approx 0.6 V_{DD}$  for power supply voltages of  $V_{DD}$  between 5 and 10 volts. What part of the data sheet are you using?

**Question 2:** Use the datasheet to argue that the negative-going threshold voltage may be given by  $V_n \approx 0.4 V_{DD}$  for power supply voltages of  $V_{DD}$  between 5 and 10 volts. What part of the data sheet are you using?

**Question 3:** Set up your own laboratory experiment on the Schmitt trigger to improve the approximations  $V_p \approx 0.6 V_{DD}$  and  $V_n \approx 0.4 V_{DD}$ . Describe your experiment using circuit schematics and explain how you found  $V_p$  and  $V_n$ . Hint: you will need a powered Schmitt trigger, a potentiometer, and the M2k.

**Question 4:** Build the oscillator shown in the schematic below. Capture a screenshot of the oscilloscope view of the voltage across the capacitor (like Figure 5, to include in this report).

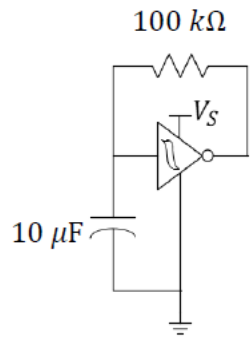

**Question 5:** From your oscilloscope measurement, record the capacitor's highest and lowest voltage values. Compare them to your values of  $V_n$  and  $V_p$  in the previous question and explain why they should be the same.

**Question 6:** Does the equation-predicted frequency match the frequency you found in the circuit above? Discuss any reasons there may be deviations.