

# Straight-Run Car

---

## Prerequisites

- PWM using Diodes
- Build of the shadow chassis car and previous build of the nMOS-based motor-drive circuit.

## Learning Objectives

- Build a circuit by following the design specified on a circuit schematic
- Learn to control the duty cycle of a PWM signal using a turn pot and diodes
- Use observations of your circuit to discern the change of certain components.
- Adjust your PWM signal to different duty cycles, make observations on the oscilloscope.

## How it Works (skip this section assuming you have completed the prelab)

As a prerequisite of this lab, you should have already studied and build a Pulse-Width-Modulation generator as in Figure 1 below. This was provided as a separate module. Figures 2 and 3, then describe how the output of the Schmitt trigger looks like either a voltage source (to charge the capacitor) or a short-to-ground (to discharge the capacitor). The Schmitt-trigger behavior is, in turn, controlled by the current voltage differential across that same capacitor creating a “control loop.” The diodes in combination with the potentiometer control the time-constant characteristics of these two separate paths, thus providing control of the duty cycle with the turn of the potentiometer.

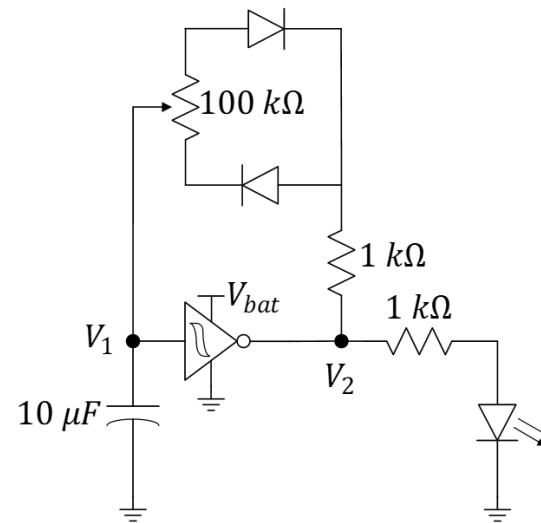

**Figure 1:** Circuit schematic of an oscillator with a selectable duty cycle from an earlier exercise.

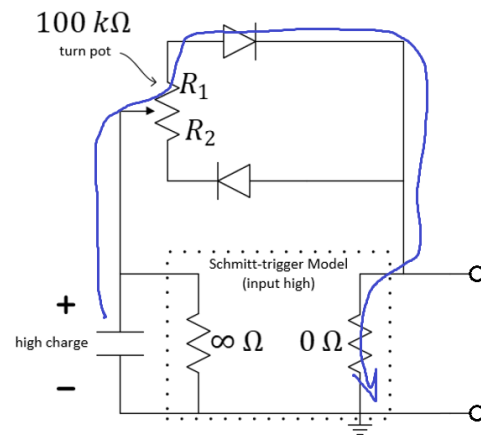

**Figure 2:** Oscillator with Schmitt-trigger modeled for "input high" (discharging cycle). (The extra  $1\ \text{k}\Omega$  not shown.)

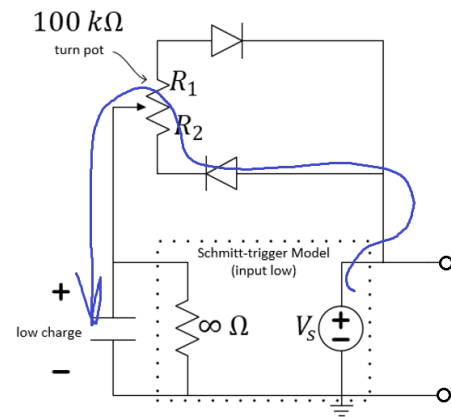

**Figure 3:** Oscillator with Schmitt-trigger modeled for "input low" (charging cycle). (The extra 1 kOhm not shown.)

## How to Build it

Let's start with a slight redesign of the PWM signal as we want it to operate on the order of hundreds of Hz. Switch the capacitor to a value of  $1\ \mu\text{F}$  (marked with **105** meaning 10 plus 5 more zeros or 1,000,000  $\text{pF}$ ). The smaller capacitor will charge and discharge more quickly and therefore reduce both the charging and discharging time constants and increasing the frequency of oscillation of the PWM signal.

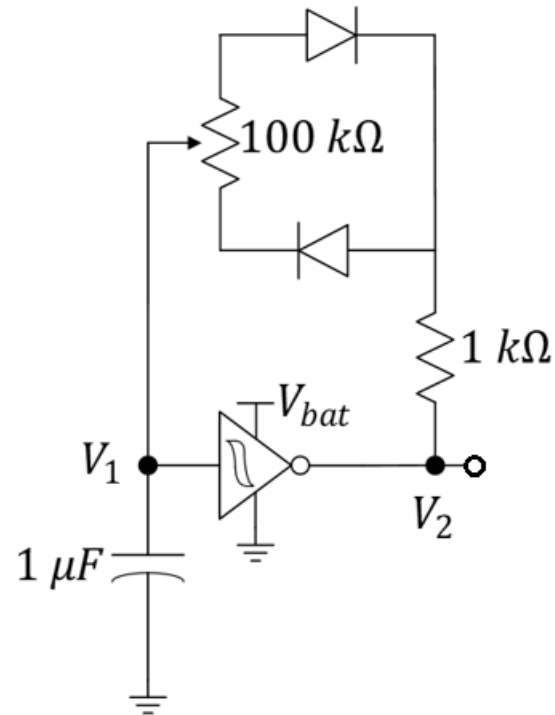

**Figure 4:** Circuit schematic of an oscillator with a selectable duty cycle and higher frequency of operation.

Build the motor-control circuit below that includes an adjustable wheel-speed balance potentiometer. You should see the familiar motor-drive circuits as well as the oscillator of Figure 4. You may be surprised to see three Schmitt-trigger inverters in this design. The first Schmitt-trigger is used in the PWM oscillator design. The second Schmitt trigger buffers the oscillator circuit from the MOSFET of one motor-drive circuit so that that circuit does not cause a significant load on the oscillator that might affect its behavior. The third Schmitt-trigger inverter inverts the previous signal such that the duty cycle of the second wheel is mirrored of that of the first motor. That is, while the first wheel is driven by duty cycles that can be adjusted from 0 to 100%, the second wheel is driven by duty cycles that vary from 100% to 0%, respectively. The two duty cycles will always follow  $\%dc_1 + \%dc_2 = 100$ . The diodes across the motor are “flyback” diodes that will protect the MOSFETs from damage. The motors act much like inductors and their the current cannot stop immediately (Physics 212 stuff). Flyback diodes allow a safe path for this current to travel when the transistors suddenly turn off (when the drain-to-source connection becomes an open-circuit).

Notes:

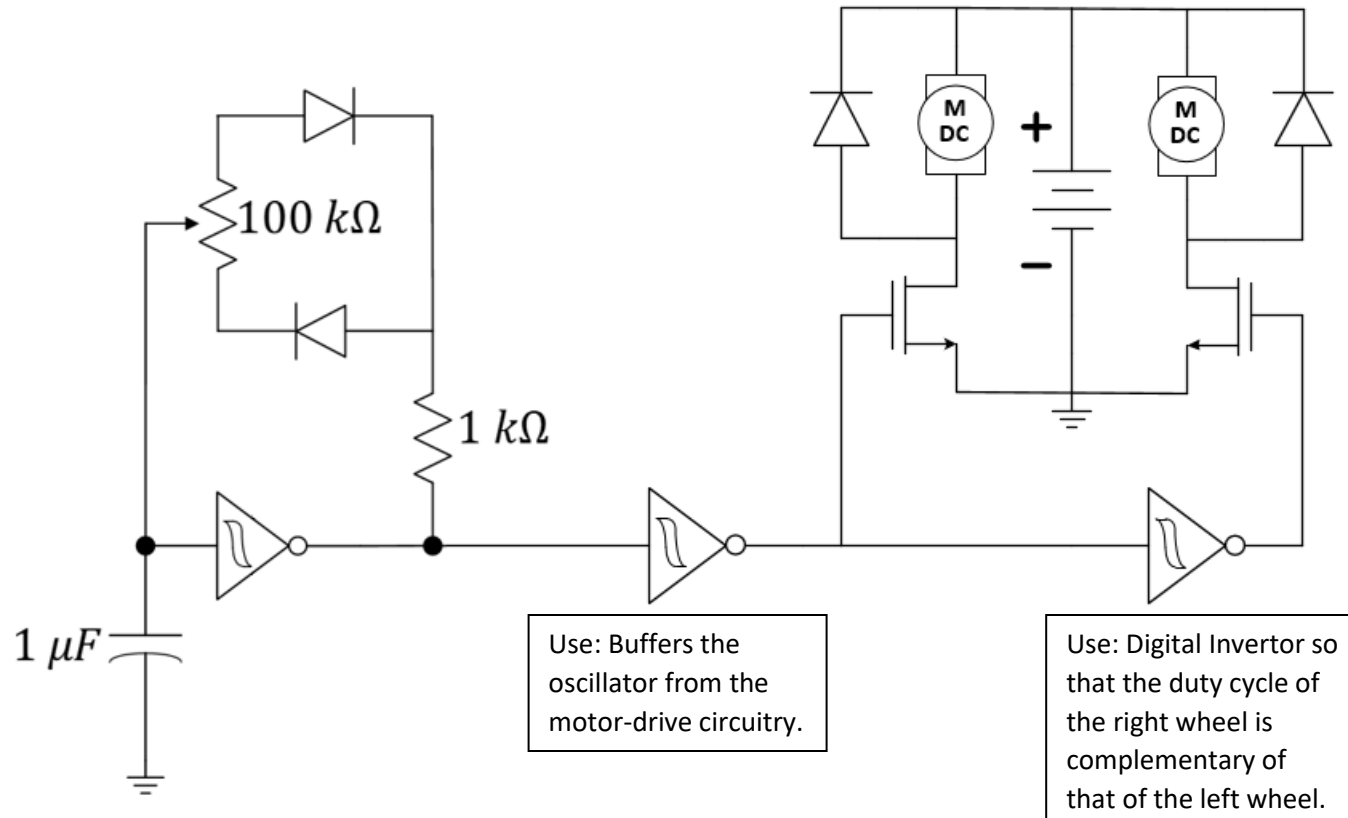

**Figure 4:** PWM-based wheel balancer. Be sure to apply power and ground to the Schmitt trigger. One IC can supply all three Schmitt triggers. See the datasheet.

The term **orthogonal** is derived from the Greek orthogonios ("ortho" meaning right and "gon" meaning angled).

**Orthogonal** concepts have origins in advanced mathematics, particularly linear algebra, Euclidean geometry and spherical trigonometry.

[What is orthogonal? - Definition from WhatIs.com](#)

Name: \_\_\_\_\_

UIN:

--	--	--	--	--	--	--	--	--	--

Section AB/BB:

--

Notes:

---

**Question 1:** Use rise-time and fall-time equations to estimate the frequency of oscillation when the duty cycle is set to 50% for the oscillator of Figure 4. Explain your reasoning.

**Question 2:** Use the equations to estimate the minimum and maximum duty cycle available for the oscillator of Figure 4. Explain your reasoning.

**Question 3:** Tune the potentiometer to make the chassis run in a straight line. You can first tune your duty cycle to 50% (using the M2k if you wish), then do fine tuning by making small adjustments and running your car on the ground. What is the minimum distance your car deviates from that line in, say, 2 meters distance?