

Pulse-Width Modulation using Diode Magic

Prerequisites

- Definition of Duty Cycle (see course notes)
- How to build an oscillator using a Schmitt Trigger.
- The functions of diodes.

Learning Objectives

- Build a circuit by following the design specified on a circuit schematic
- Learn to control the duty cycle of a PWM signal using a turn pot and diodes
- Use observations of your circuit to discern the change of certain components.
- Adjust your PWM signal to different duty cycles, make observations on the oscilloscope, and explain those observations in technical terms.

Pulse-Width What?

In robotics design, controlling the rotational speed of motors is a critical task. The speed of a motor *can* be controlled through the use a current-limiting resistor placed in series with the motor. With less current, the motor will indeed run more slowly. But there is a serious problem with this method. The motor will lose torque and is more likely to stall entirely instead of running at a low speed.

A better method of wheel-speed control is achieved through Pulse-Width Modulation (PWM). In fact, this is the standard method used in robotics. To understand the terminology, we can pick the terms apart. The term “modulation” refers to the control or inflection of a value. In this case, it is the width of the pulse of a square wave signal that is being altered. In fact, it is the duty cycle, or the ratio of the time the square wave is at its high voltage to the total period of the square wave as shown in Figure 1.

$$\text{duty cycle: } D = \frac{T_{on}}{T}$$

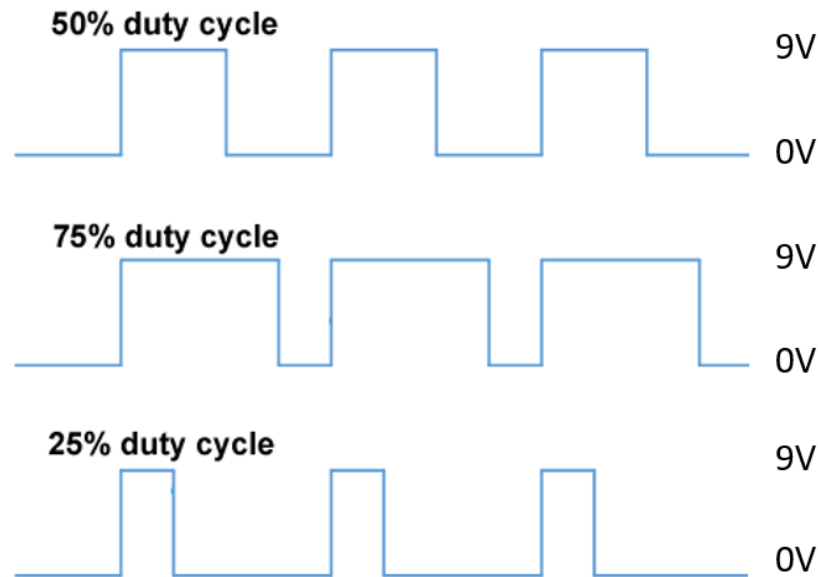

Figure 1: Examples of varying duty cycles.

Driving the motor with a square wave with sufficiently-high frequency will cause a motor to turn with high torque, even as the motor slows. The motor will not pulse as you might think, but instead momentum plus the energy storage of the motor's windings result in a smoothly-turning motor. Using a duty cycle close to 1 (100%) will result in the wheel running as through the full battery is applied across it. Lower duty cycles will result in lower wheel speed. However, keeping the drive voltage high during the pulses keeps the motor out of a stall.

In Figure 2 (a), a square-wave oscillator with a (near-) 50% duty cycle is shown. The frequency of this oscillator may be adjusted by proper selection of the RC time constant. In Figure 2 (b), we show how the use of diodes can differentiate the charging and discharging path of the capacitor such that the two operations may have different time constants and, therefore, the square-wave oscillator will have a duty cycle that is adjustable.

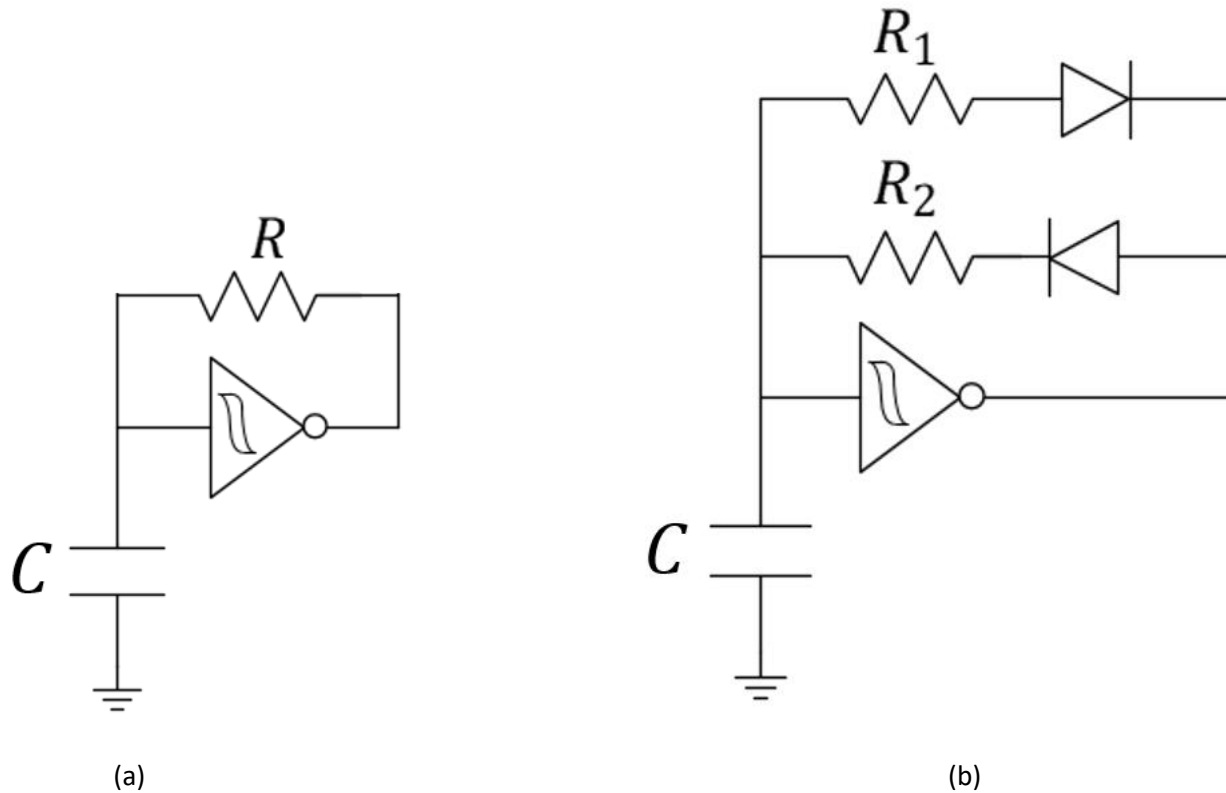

Figure 2: Circuit schematic of a traditional oscillator (a) an oscillator with a selectable duty cycle (b).

How it Works

By placing a capacitor at the input of the inverter (see Figure 1 a), discharging the capacitor will cause the output of the inverter to be near the battery voltage (that's what an inverter does...“inverts” its input voltage). By charging the capacitor, the output of the inverter will be near 0 volts. By inserting a resistor between the output and the input (where the capacitor sits), the output does the job of **both** charging and then discharging the capacitor, thus forming an oscillator. An **oscillator** is a device that changes values over time in a periodic manner.

If we desire control over the duty cycle of our square wave, we can consider using different resistance in the charging phase than in the discharging phase of oscillation. We can use signal diodes (the small ones taped together and **not** the thicker-wired Zener diode in your kit) to change which resistive path is used.

In this configuration, the capacitor will discharge through R_1 , but charge through R_2 due to the current restrictions determined by the diodes. Think about the charging and discharging phases of your capacitor. The resistors R_1 and R_2 control the rates at which the capacitor, C , discharges and recharges, respectively.

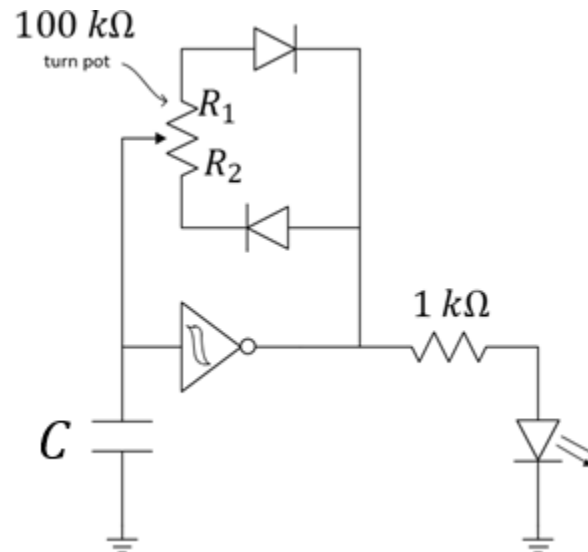

Figure 3: Circuit schematic of an oscillator with a selectable duty cycle.

Recall that the output of the Schmitt trigger looks like either a voltage source (to charge the capacitor) or a short-to-ground (to discharge the capacitor). The Schmitt-trigger behavior is, in turn, controlled by the current voltage differential across that same capacitor creating a "control loop." The diodes in combination with the potentiometer control the time-constant characteristics of these two separate paths, thus providing control of the duty cycle with the turn of the potentiometer.

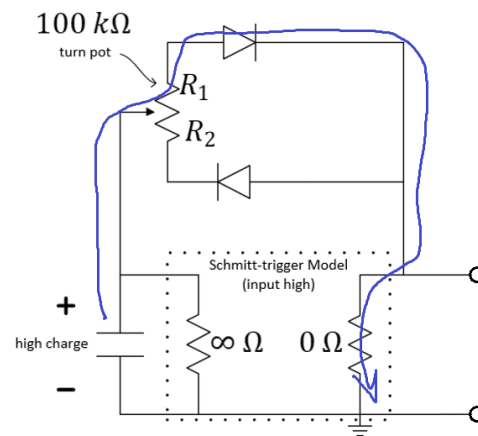

Figure 4: Oscillator with Schmitt-trigger modeled for “input high” (discharging cycle).

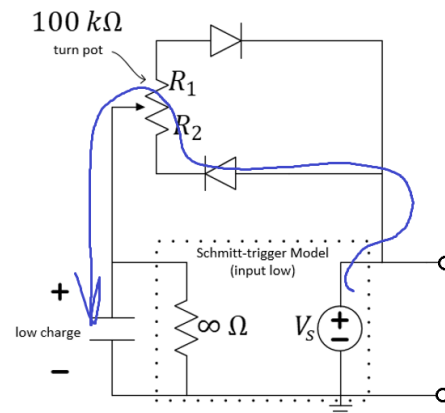

Figure 5: Oscillator with Schmitt-trigger modeled for “input low” (charging cycle).

How to Build a *Robust* PWM device

We can make the design resistant to damage (we might say, it is **robust**) through the addition of the upper $1\text{ k}\Omega$ resistor of Figure 6. This resistor will alter both the charging loop and the discharging loop for a $C = 1\ \mu\text{F}$ capacitor. We have added this current-limiting resistor to prevent possible damage to the potentiometer when you set it near its extreme positions...smaller

resistance can often lead to higher power dissipation and we do not want the potentiometer pushed beyond its power rating. You will need to keep this extra resistor in mind while answering the questions at the end.

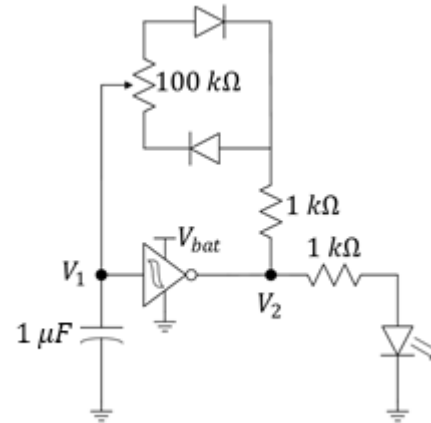

Figure 6: PWM oscillator controlled by a potentiometer. Warning: The $1 \mu F$ capacitor is polarized! Be sure to insert the negative lead into the ground rail. Also, do not forget the power and ground on the Schmitt-trigger.

Build the Pulse-Width Modulation device in Figure 6. Place the M2k's probes of **channels 1 and 2** to measure V_1 and V_2 (where does your "negative" probe go in each case?). **Use your $100 \text{ k}\Omega$ potentiometer to adjust the duty cycle to 40% and then to 60%.** Use the **measure** option to do this accurately.

Name: _____

UIN:

--	--	--	--	--	--	--	--	--	--

Section AB/BB:

--

Notes: _____

Question 1: Record a video demonstrating the turning of the potentiometer in the **counter-clockwise direction** while observing your waveforms on the M2k oscilloscope.

Question 2: Use your duty cycle measurements to decide which resistance of Figure 6 (R_1 or R_2) increases as you turn your potentiometer counter-clockwise. Explain.

Question 3: Predict the maximum and minimum duty cycles of Figure 6 based on the relative time constants of the charging and discharging paths.

Question 4: Record the minimum and maximum duty cycle of your oscillator and explain if they match your predictions.

Question 5: Briefly describe the effect of duty cycle on your LED.