

Name: _____

UIN:

--	--	--	--	--	--	--	--	--	--

Section AB/BB:

--

PRE-LAB #5: Square-Wave Oscillator

Background

Last week, we built a voltage divider that utilized a photoresistor to create a voltage that responds to the level of ambient light. An LED with a current-limiting resistor was used as an output to indicate passing shadows. We used an inverter (specifically, a Schmitt trigger) to both buffer the voltage divider from the LED so that both circuits worked as designed without “loading” the other in a way that compromised its design. In this prelab exercise, we will again use the inverter but in a new way. By placing a capacitor at the input of the inverter (see Figure 1), charging the capacitor will cause the output of the inverter will be near 0 volts. Discharging the capacitor will cause the output of the inverter to be near the battery voltage. By inserting a resistor between the output and the input (where the capacitor sits), the output does the job of both providing a charging voltage and then a discharging path for the capacitor, thus forming an oscillator. An **oscillator** is a device that changes values over time in a periodic manner.

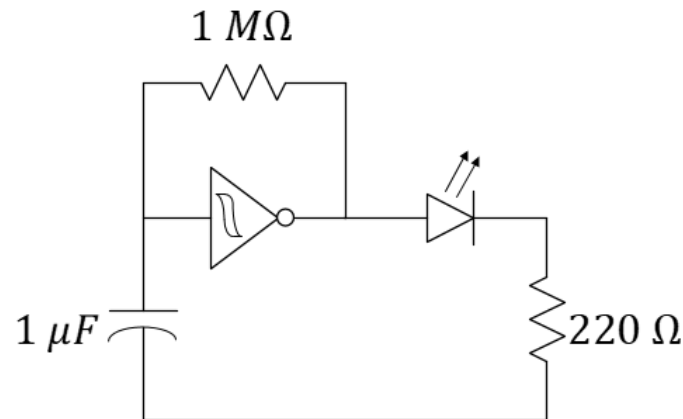
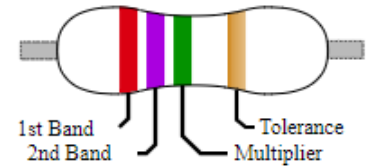

Figure 1: Circuit schematic of a square-wave oscillator producing a flashing beacon.



Color	Significant digits	Multiplier	Tolerance [%]
Black	0	1	—
Brown	1	10	±1
Red	2	100	±2
Orange	3	1 000	—
Yellow	4	10 000	—
Green	5	100 000	±0.5
Blue	6	1 000 000	—
Violet	7	10 000 000	—
Grey	8	—	—
White	9	—	—
Gold	—	—	±5 ^[nb 4]
Silver	—	—	±10

Source: Wikipedia

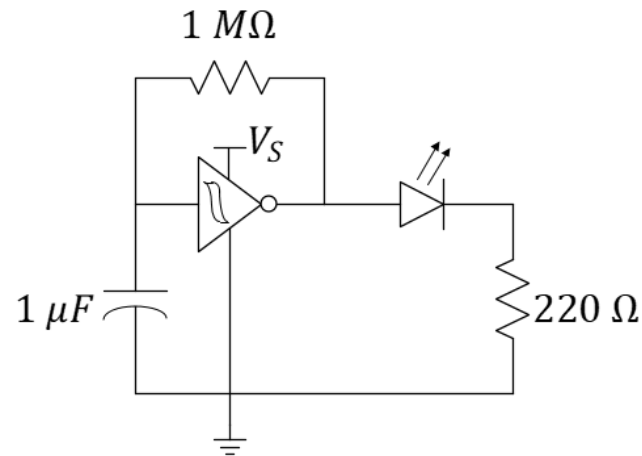
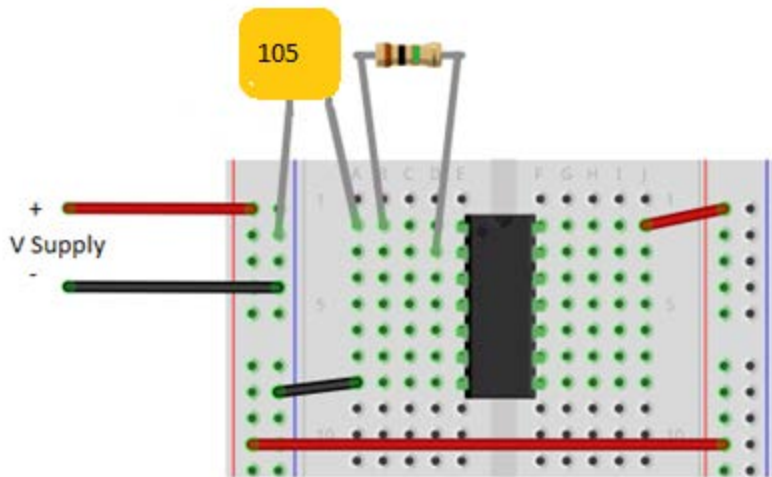

Figure 2: Physical diagram and circuit schematic of a prototype oscillator circuit. The diode and current-limiting resistor are not shown in the prior. Note that you must place the **negative side of the capacitor** at the lower voltage if using an electrolytic capacitor (this one is not polarized).

Build the oscillator circuit as shown in Figure 2. Use a blue LED to complete the design. Be sure to connect the battery + and – connections as shown. Your blue LED should be flashing every one to three seconds.

Question 1: Use a timer to see how many seconds it takes your LED to flash 20 times. Divide the number of flashes, 20, by the amount of time that passed to determine the flash frequency in units of flashes/second (*Hertz*). Show your work.

Notes:

Capacitors often provide three or more numbers to indicate the capacitance in picoFarads (pF). The first digits are precision while the last digit represents a power of 10. For example, 104 means a capacitance of 10×10^4 pF or, equivalently, $0.1 \mu F$. The electrolytic capacitor used here is physically large enough to write out the capacitance plus the unit in addition to its rated voltage. Note that it is polarized! You must place the negative side of the capacitor at the lower voltage...in this case, the negative end of the power supply.

Question 2: *Think about it.* Your lab mates are also building the same circuit. Will theirs have exactly the same flashing frequency as yours? Explain.

Learning Objectives

- Build a circuit by following the design specified on a circuit schematic
- Learn the applied definitions of synchronous and asynchronous, coherent and non-coherent.
- Use an LED as an output indicator

Notes:

Do you know the definition of *synchronous*? You can research it online. It is very similar to a term we use to describe signals that match in frequency (and possibly phase), *coherent* signals.