

Name/NetID:

Teammate/NetID:

Experiment 9: Autonomous and Elegant!

Laboratory Outline:

Breakout Session #1



Critique each other's breadboard from the prelab design.

Question 1: Write down one or more ideas for neat circuit design that you have learned from your peers.

At Your Bench

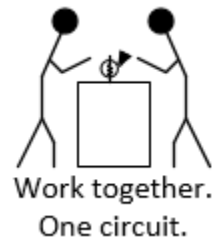

Section AB/BB:

0 1 2 3 4 5 6 7

8 9 A B C D E F

(circle one)

If necessary, rebuild your motor-control circuit below using a “clean” design as developed in your prelab. As you rebuild, use your oscilloscope during the rebuild to ensure that each part is properly functioning **before** you cascade them together. That is, you should verify the oscillators’ outputs and their “inverted” counterparts are fully functioning before attaching them to the logical AND.

Once your circuit is in a satisfactory state, have your TA validate your car’s operation you before you continue.

Set both oscillators to a duty cycle near 50%.

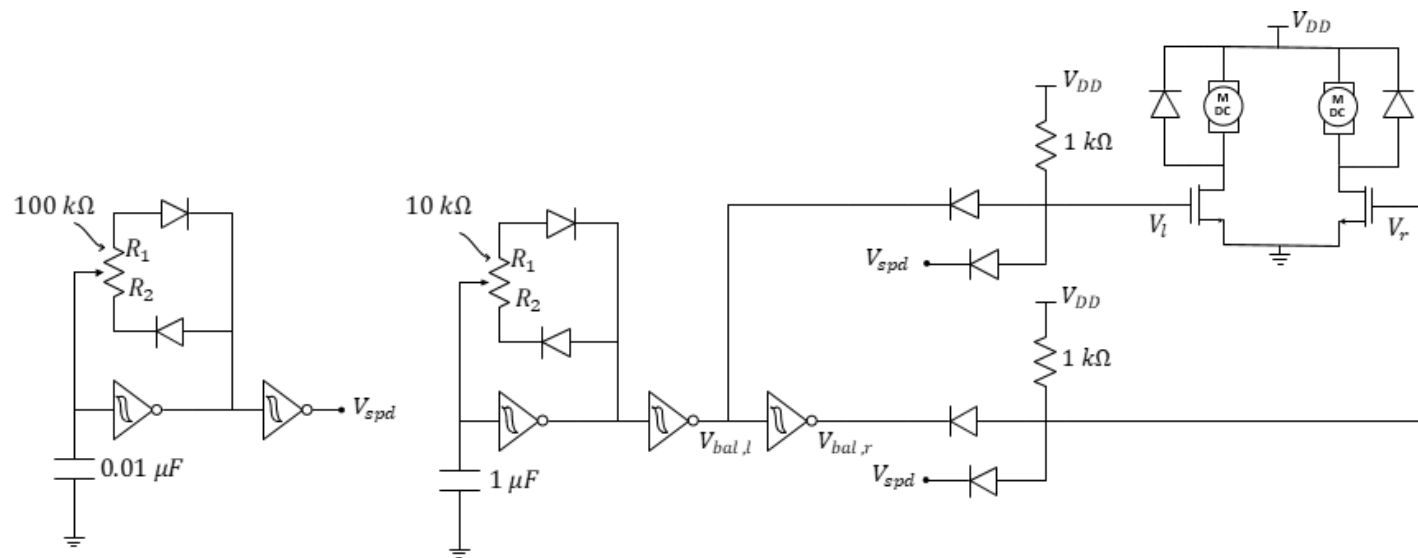

Figure 1: PWM-based wheel balancer plus speed control.

Once your circuit is clean and operable, continue to the next section.

Curb-Feeling Autonomous Vehicle

Previously, you ran the geared wheel motors using various methods, but always in “open loop”. That is, you didn’t use feedback. Now sensors will be used in feedback to control the speed of each wheel. Specifically, the snap-action switches will alter the feed of the pulse-width modulated (PWM) signals to control the speed of the car’s motors.

Your task is to complete the construction of an autonomous, wall-following robot car. The car must be able to drive through the corridor that has been built for it without getting stuck. One approach to accomplishing this design is to use the snap-action switches to *feel* the walls of the corridor and adjust the wheel speeds when the wall is close to one side of the car. The diagram below depicts an example corridor layout that your car should be able to navigate.

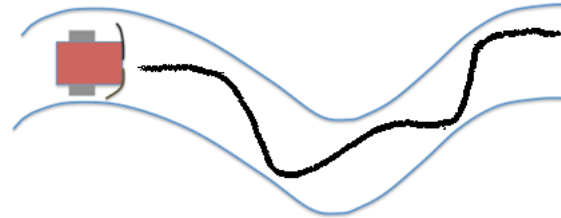

Figure 2. A curb-feeling (wall-avoiding) autonomous vehicle and its possible path through a tunnel.

In this way, each snap-action switch acts as an interface with the environment around the car. When toggled, the switch has detected that an object (the wall) is near that side of the car. With this in mind, consider how we want the car to behave. In this particular design challenge, there are only three cases that are important to our control design.

1	No walls on either side	The car should drive straight forward
2	A wall on the left side	Car turns right (left wheel faster than right)
3	A wall on the right side	Car turns left (right wheel faster than left)
4	A wall in front	Pick vehicle up and start over

Table 1: Important navigational conditions.

Figure 3 introduces the addition of two snap-action switches. The snap-action switches will complete a so-called closed loop control system where the switches serve as an input to the car, changing the relative speeds of the motor and, therefore, also changing the distance of the sensors from a wall.

Question 2: Which sensor should be connected to the left wheel motor of the car, the left or the right sensor?

Notes: _____

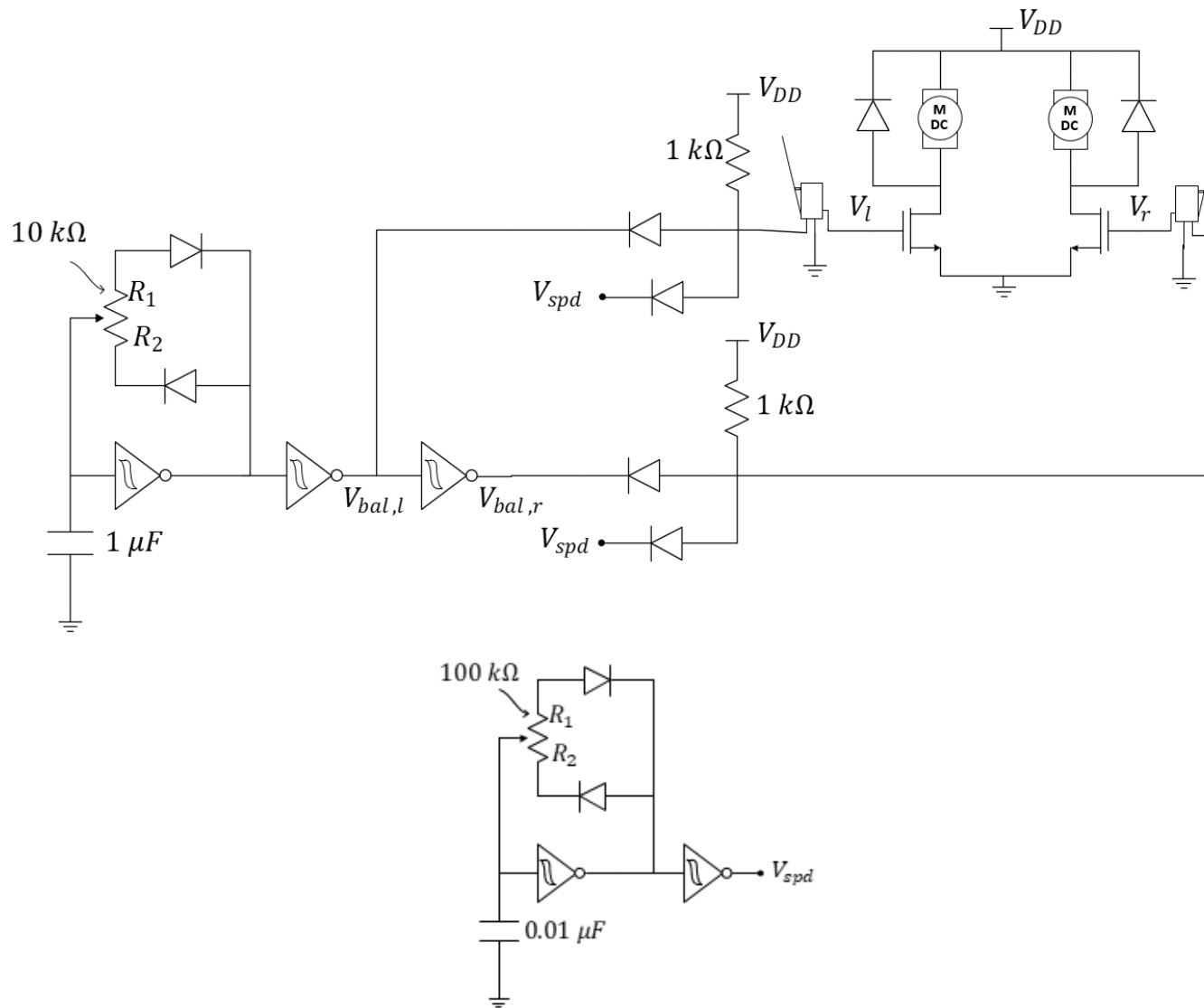

Figure 3: Adding snap-action switches for wall-following control.

Notes:

To add the snap-action switches to your car, slide the “common” wire into the center hole of one of the “struts” as shown in Figure 4, then continue to slide the snap action switch into place where the “spade” connector of the common wire will hold the sensor in place. Feel free to use a small dab of glue from the hot-glue gun or secure it in place with a longer wire from your wire kit if the sensors does not appear to stay firmly in its place.

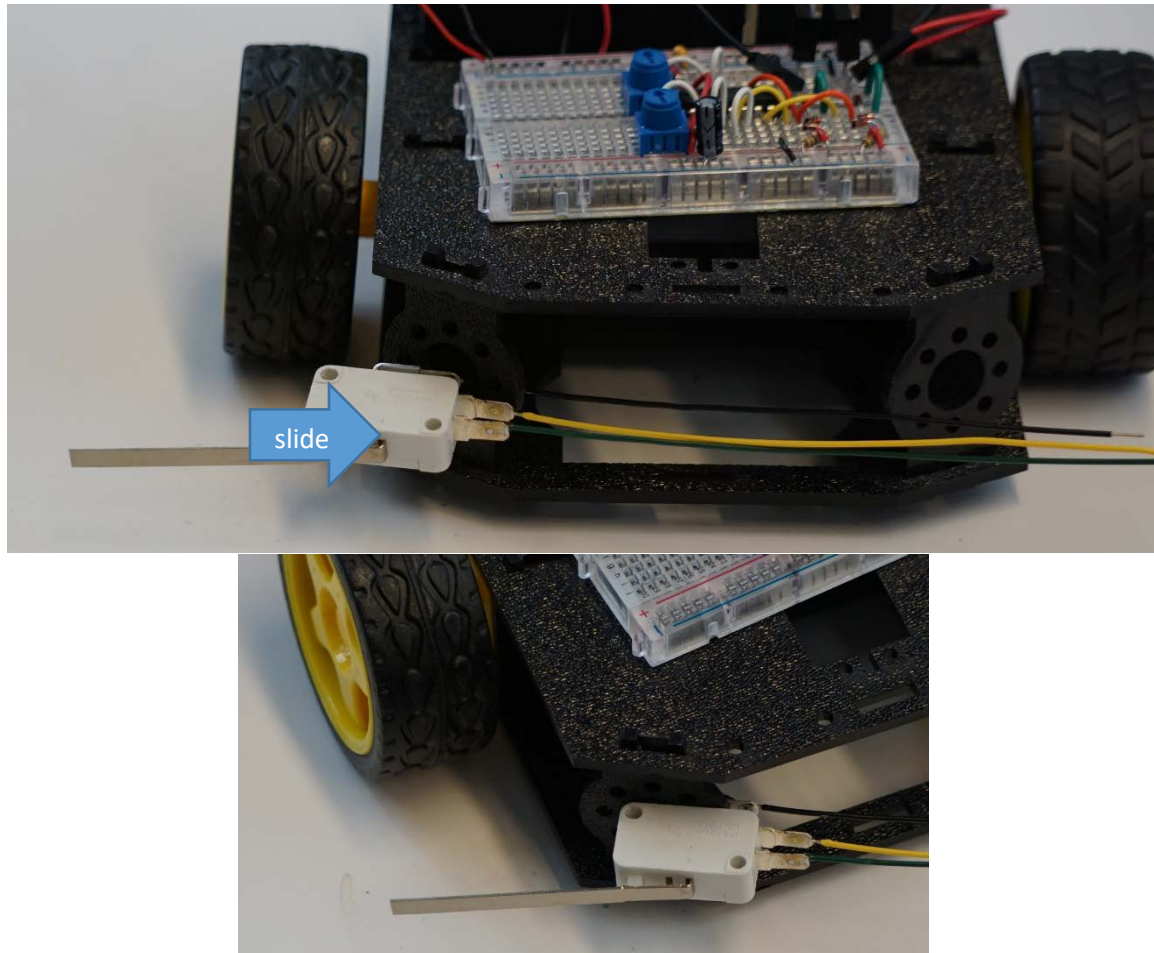

Figure 4: Before connecting the snap-action switches to your circuit, connect them to the car chassis as shown here.

With the sensors in place, connect them to your circuit as shown in Figure 3. Validate operation and then head to the breakout area to test and modify your circuit as needed.

Explore More! Modules

Explore More! Modules provide students with options to investigate new concepts! As time allows, do one or more of the modules before returning to the laboratory's core procedure.

This week, we highly recommend the following *Explore More! Modules*:

<i>Explore More! 8B The Clipping Circuit</i>	<i>Explore More! Schmitt Trigger IV</i>	<i>Explore More! Voltage-Follower Buffer</i>
--	---	--

Breakout Session #2



At the breakout area, you may run your car **along the edge of the table**.

Adjust the wheel balance that the car has a slight inclination to turn towards the left with the wall to left. Adjust the wheel speed as necessary for fast, but reliable control.

Question 3: Comment on the success of your vehicle in tracking the wall on the left.

Adjust the wheel balance that the car has a slight inclination to turn towards the right with the wall to right. Adjust the wheel speed as necessary for fast, but reliable control.

Question 4: Comment on the ease of altering the car to follow the wall on the right. Briefly explain the design of your circuit that made this possible.

Question 5: Demonstrate your solution to your TA on the white wall with decreasing radius. Your TA will initial the Summary page if satisfied with your design.

Learning Objectives

- Deeper skills in building cascaded circuits.
- Gain experience in building a clean circuit.

Congratulations! You have now successfully created an autonomous vehicle. In doing so, you have learned to use the oscilloscope as a developer's tool. You also have learned enough about circuits to consider doing your modifications to the vehicle. How about exploring the operation of infrared emitter/detector sensors to do "line-following" instead of "wall-following"? Perhaps, you could explore the operation of the ultrasonic sensor to avoid or even seek objects at some distance from the car? Or, perhaps you now have your own ideas for how you might start your own circuit project from scratch, incrementally exploring the sensors, circuits, cascading of circuits, and artistry required to design something brand new!

Notes:

Lab 9 Summary (To be submitted at the end of the laboratory session)

Question 6: In the space below, discuss briefly the many design elements of your car.

Question 7: Discuss with your peers ideas that would enhance the abilities of this vehicle. List these ideas along with the type of circuit behavior you would need to make these ideas a reality.

For TA use only:

- Prelab Check: full/half/zero credit
- Student was engaged throughout the lab, not distracted by phone, homework, etc.
- Student demo was successful.

TA initials: _____

TA initials: _____

TA initials: _____

Lab grade (reasons for deductions and/or total points awarded):

_____/6

Notes:

Name:

NetID:

Section AB/BB:

0 1 2 3 4 5 6 7

8 9 A B C D E F

(circle one)

Bench:

A B C D E F G H I J K L M N O P

(circle one)

Return your borrowed equipment, clean up your benchtop, and submit your lab summary before leaving for the day. Thank you!