

PRELAB #8: Autonomous Vehicle

Section AB/BB:

0 1 2 3 4 5 6 7

8 9 A B C D E F

(circle one)

Background...Our story in Pictures (Circuit Schematics, that is!)

Let's reflect on the semester's progression. With little circuit knowledge, we learned that we could control a car by pulsing on and off the two wheels. Physical limitations on the switching rate (due to the switches, motors, and our own reaction time) made this kind of human-in-the-loop control system challenging to say the least. Many Jenga blocks died a horrible death.

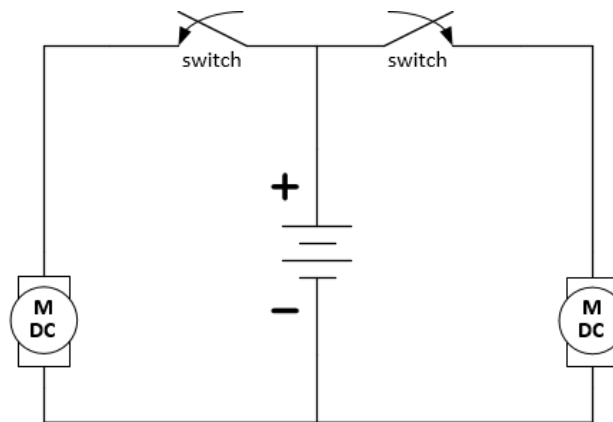

Figure 1: Bang-bang control of the motors with a human-in-the-loop. Tough to control.

Next, we discovered that the motor speed could be reduced by utilizing current-limiting resistors in series with the motors. Careful selection of a network of resistors enabled us to both slow the wheels, but also to balance the speed between the wheels so that the car ran more-naturally straight.

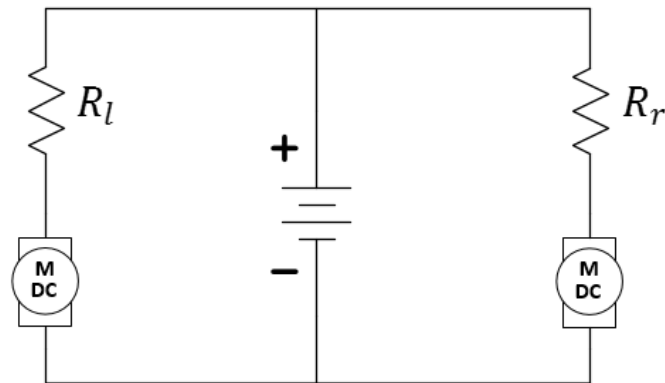

Figure 2: Current-limiting resistors when properly tuned, could make the car run straight without human control.

We built upon this idea by controlling the resistive networks such that our switching action had lesser effect on the change in wheel speed and we found that we had improved control over the car. The Jenga block casualties were greatly reduced.

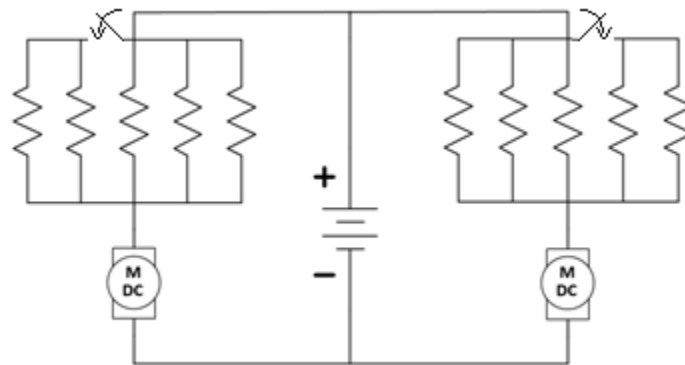

Figure 3: Fine switching differences of the current-limiting resistors improved human-in-the-loop control.

At this point, we started to pay attention to efficiency. These resistive networks must be consuming power in proportion to that consumed by the motors. How inefficient were they? That was for you to calculate in the Unit 1 report.

The issue of efficiency was tackled by the use of a power MOSFET. Controlled by a voltage of our choosing, each MOSFET would allow current flowing through one motor. Why was the efficiency improved? Because the control voltage was being produced by

a voltage divider that draws little current from the battery. Furthermore, that voltage was provided to the MOSFET with minimal current draw (a high equivalent resistance was seen looking into the MOSFET's "gate" terminal). How good was the efficiency? You have the data, you tell me!

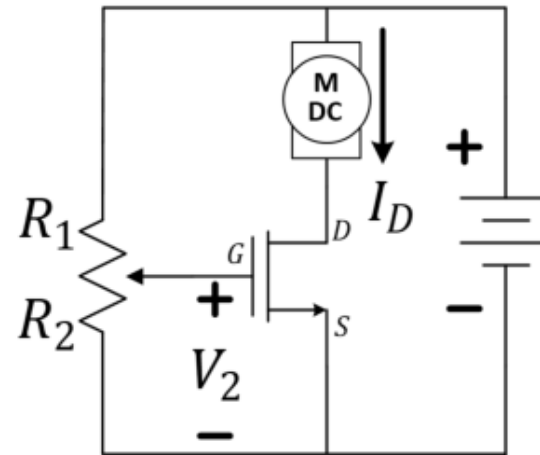

Figure 4: The use of MOSFETs and potentiometer-based voltage dividers leads to higher power efficiency and easy adjustment of straight-line vehicles.

While the speed of each wheel could be separately controlled by two voltage divider circuits, we found a way to control the overall car speed by pulsing the voltage divider's high-side voltage with a square-wave signal and did so using an oscillator that we built. This had the effect of slowing the car to nearly half of the "full-voltage" speed, but has another benefit. Square-wave signals are often used in motor-drive designs because they pulse the wheels at full voltage reducing the risk of stalling. We also became familiar with the idea of "buffering" our circuits to prevent one "sub-circuit" from "loading" another in way that our earlier circuit designs might fail. We used an extra inverter as this buffering element.

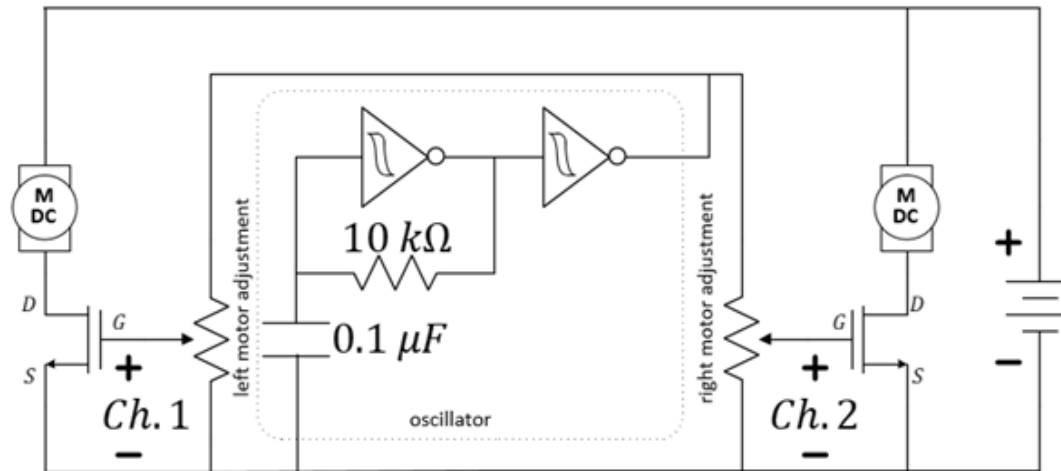

Figure 5: MOSFETs plus voltage dividers plus square wave pulses allow for efficient, tunable, slower straight-line vehicles.

Moving away from speed control, we returned to the wheel-balance problem. Through the magic of diodes and the study of circuitry, we discovered a way to create a square-wave signals with an adjustable duty cycle—a Pulse-Width Modulation (PWM) signal. Using this signal and its “logical” inverse, we were able to balance the wheel speed with the turn of a single potentiometer and, therefore, get a car that would run remarkably straight.

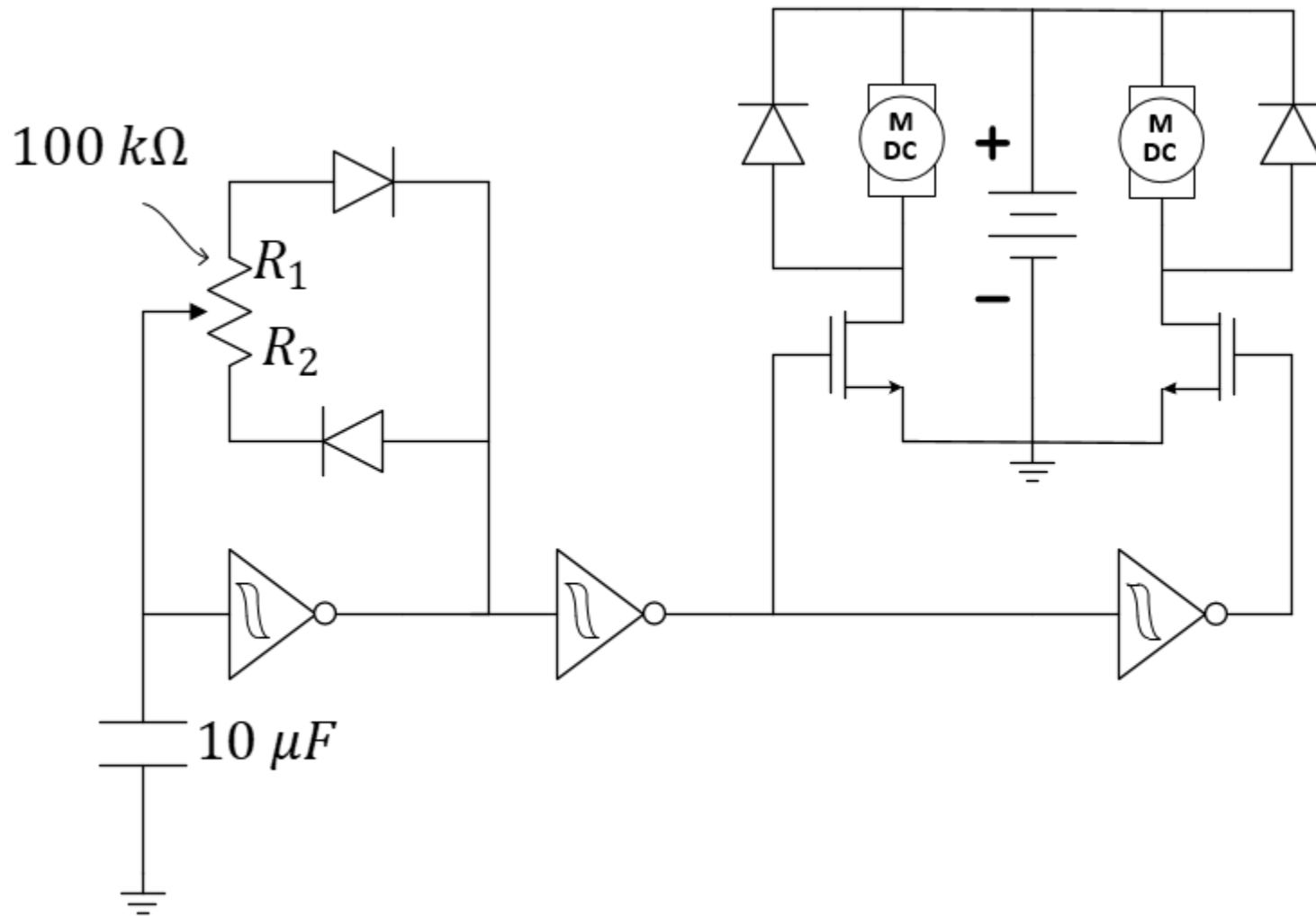

Figure 6: Replacing the two potentiometer-based wheel speed controllers with a single PWM-based wheel tuner.

We now have two more objectives to bring our car to full autonomy. We will reintroduce speed control and we will reintroduce switches. **Different from last time**, we will not control our switches by hand. We will connect them to our vehicle in a manner which will allow the car to self-adjust and move away from obstacles (in this case, the wall) that might impede its progress.

Wheel Tuning plus Speed Control (Diode-Based Logic Circuit)

To attain a way in which to simultaneously control the balance between wheels and the overall speed control, we need a method to combine two signals. To simplify, we will just consider a single wheel, say, the left wheel. That wheel will be controlled by two voltage signals. Let's call them V_{bal} and V_{spd} for balance and speed control and they are somehow combined to produce the left motor-drive voltage, V_l . Each of these signals will, at any point in time, take on a voltage near 0 volts or a voltage near that of the battery, V_{bat} . To merge these two signals into a single control signal for the wheel, we will use a diode-based logical device often called an AND GATE. We desire a signal that is high only when V_{bal} and V_{spd} are both simultaneously high and otherwise low. This is illustrated in Table 1

V_{bal}	V_{spd}	V_l
0	0	0
0	V_{bat}	0
V_{bat}	0	0
V_{bat}	V_{bat}	V_{bat}

Table 1: Desired relationship between the left-wheel control signal and inputs V_{bal} and V_{spd} .

While this is the general behavior we want, we can tolerate some deviations from these voltages; they need not be exactly equal to 0 or V_{bat} (with respect to the battery's negative terminal, of course).

Below is a proposed circuit to achieve this AND operation.

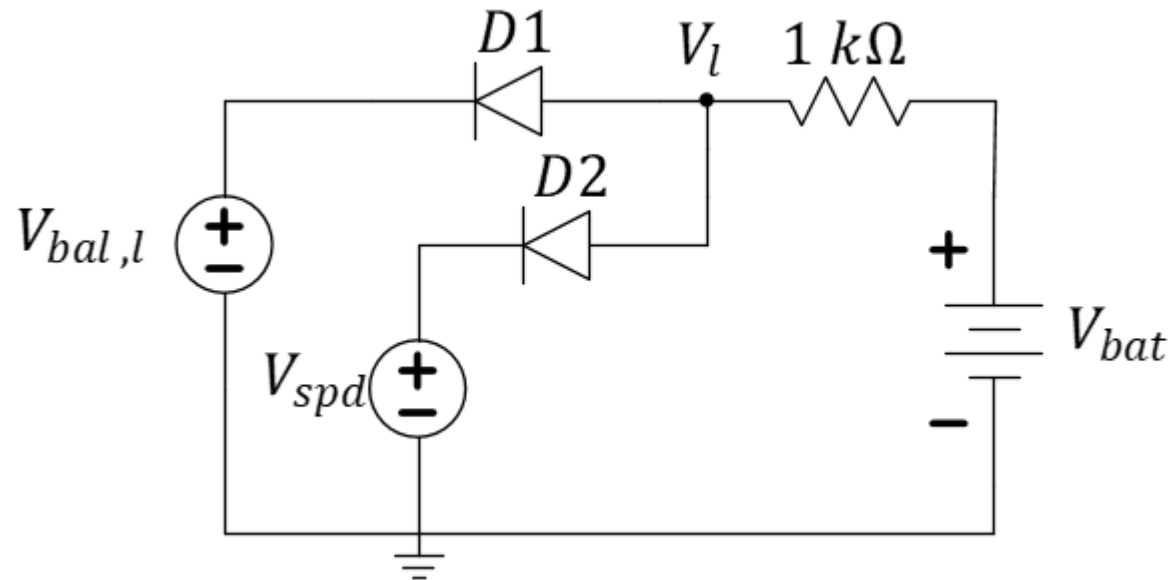

Figure 7: A diode-based logical-AND circuit for “joining” two PWM signals.

V_{bal}	V_{spd}	V_l
0	0	
0	8.7 V	
8.7 V	0	
8.7 V	8.7 V	

Table 2: Derived relationship between the left-wheel control signal and inputs V_{bal} and V_{spd} using the diode-based AND circuit.

Question 1: Assume $V_{on} = 0.7 \text{ V}$ and $V_{bat} = 8.7 \text{ V}$. Use the circuit schematic to solve for the voltage V_l under the four conditions represented by each row.

Notes:

Question 2: Build this circuit on your breadboard using signal diodes.

Question 3: Since the turn-on voltage of a (silicon) signal diode is near 0.7 volts, we can place a blue LED between V_I and ground and it will be illuminated when the so-called “left-motor voltage”, V_I , is high. Use wires to attach V_{bal} and V_{spd} to either ground or the battery voltage to test the various conditions and ensure that the blue LED is only illuminated when both inputs are connected high.

Question 4: Attach the plots you gathered in Experiment 7 Question 4.

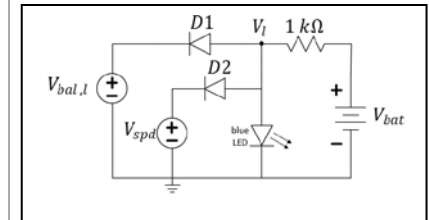

Have your circuit functional **before** arriving in your next laboratory session. As always, bring your circuit to the next lab session for grading.

Learning Objectives

- Build a circuit by following the design specified on a circuit schematic
- Learn to control the duty cycle of a PWM signal using a turn pot and diodes
- Use observations of your circuit to discern the change of certain components.