

Experiment 7: PWM Motor Wheel Balance

Laboratory Outline:

In the prelab, you constructed a square wave signal with an adjustable duty cycle typically called a Pulse-Width-Modulated (PWM) signal. In an earlier lab, you used different resistances to attempt to balance the speed of your two wheels. While this method was effective, it also had a very low power efficiency ($\eta = \frac{P_{useful}}{P_{input}}$) and was prone to motor stalls if attempting to significantly reduce the speed.

Today, we will implement a method of wheel balance that utilized the MOSFET-based motor drives for high efficiency and PWM control for high-motor torque and lower risk of motor stalling. A single potentiometer allows for a simple method of adjustment to make the car run a straight path.

Breakout Session #1

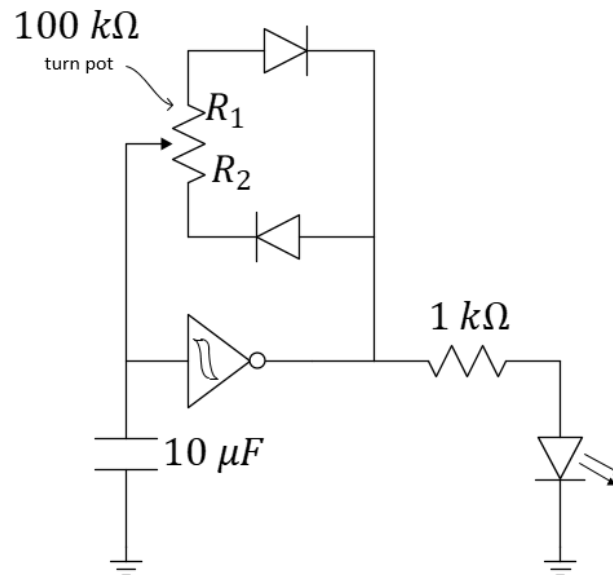

Figure 1: Circuit schematic of an oscillator with a selectable duty cycle.

Section AB/BB:

0 1 2 3 4 5 6 7

8 9 A B C D E F

(circle one)

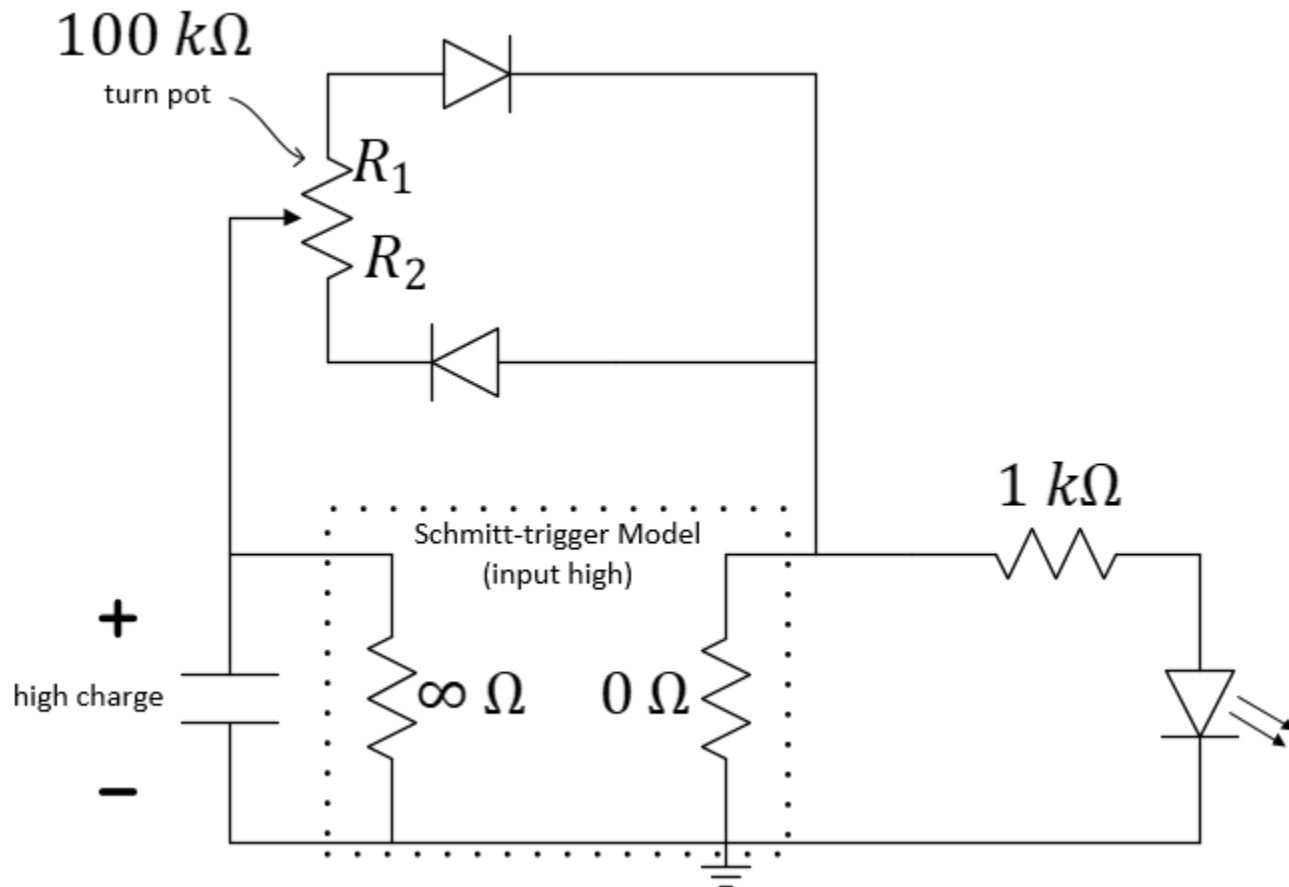

Figure 2: Oscillator with Schmitt-trigger modeled for "input high".

Question 1: On Figure 2, mark the "loop" through which the capacitor discharges. Label that loop "L1".

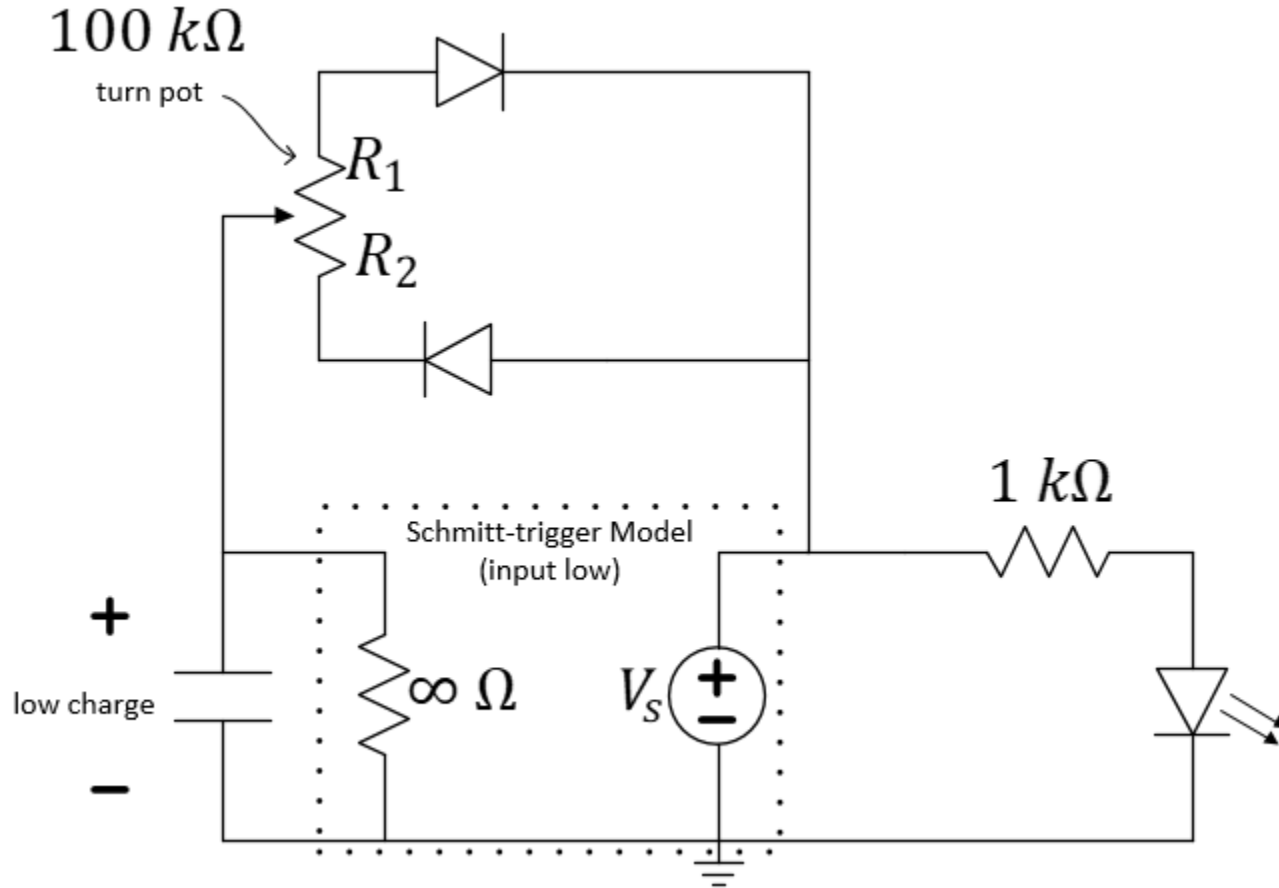

Figure 3: Oscillator with Schmitt-trigger modeled for "input low".

Question 2: On Figure 3, mark the "loop" through which the capacitor charges. Label that loop "L2".

Question 3: How would the charge and discharge phases of the oscillator be compromised if the input resistance of the Schmitt trigger was small instead of large (say $\sim 100 \Omega$ instead of $\infty \Omega$)? Would oscillation be likely to occur? Explain.

At Your Bench



Build the motor-control circuit below that includes an adjustable wheel-speed balance potentiometer. You should see the familiar motor-drive circuits as well as the recently-constructed oscillator. You may be surprised to see three Schmitt-trigger inverters in this design. The first Schmitt-trigger is used in the PWM oscillator design. The second Schmitt trigger buffers the oscillator circuit from the MOSFET of one motor-drive circuit so that that circuit does not cause a significant load on the oscillator that might affect its behavior. The third Schmitt-trigger inverter inverts the previous signal such that the duty cycle of the second wheel is mirrored of that of the first motor. That is, while the first wheel is driven by duty cycles that can be adjusted from 0 to 100%, the second wheel is driven by duty cycles that vary from 100% to 0%, respectively. The two duty cycles will always follow $\%dc_1 + \%dc_2 = 100$.

Notes:

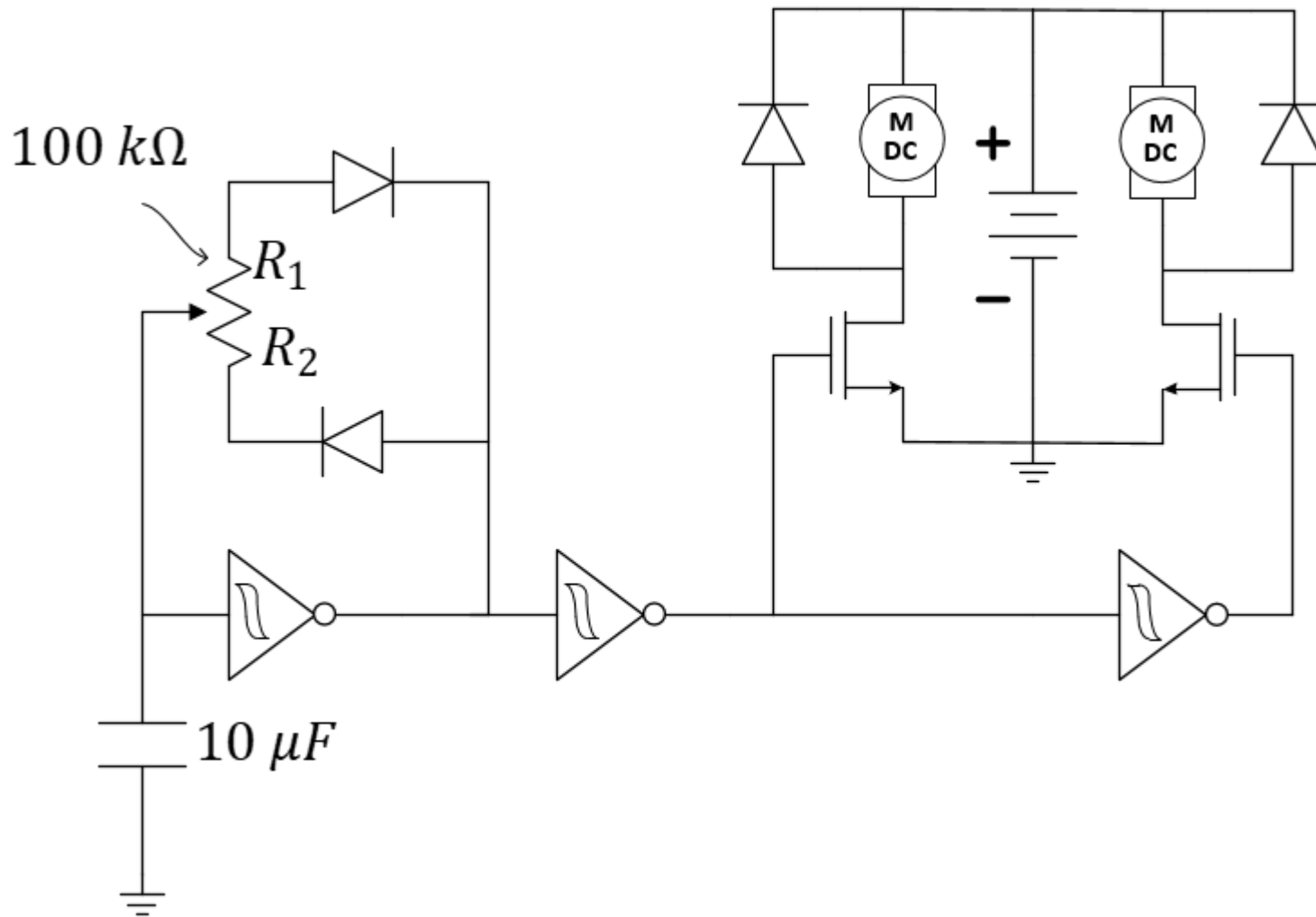

Figure 4: PWM-based wheel balancer.

Disconnect the motors from the positive side of the battery to disable them for now. Place the probes of **channels 1 and 2** between the circuit ground and the two outputs of the inverters (MOSFET gates) as shown in the figure below. After pressing the **Default Setup** button on the scope, adjust the scopes **vertical, trigger, and horizontal settings**, respectively, to get a nice

view of the two *orthogonal* waveforms. Use your $100\text{ k}\Omega$ potentiometer to adjust the duty cycle so that Channel 1 is at 40% and Channel 2 at 60%. Use the **measure** button to do this accurately.

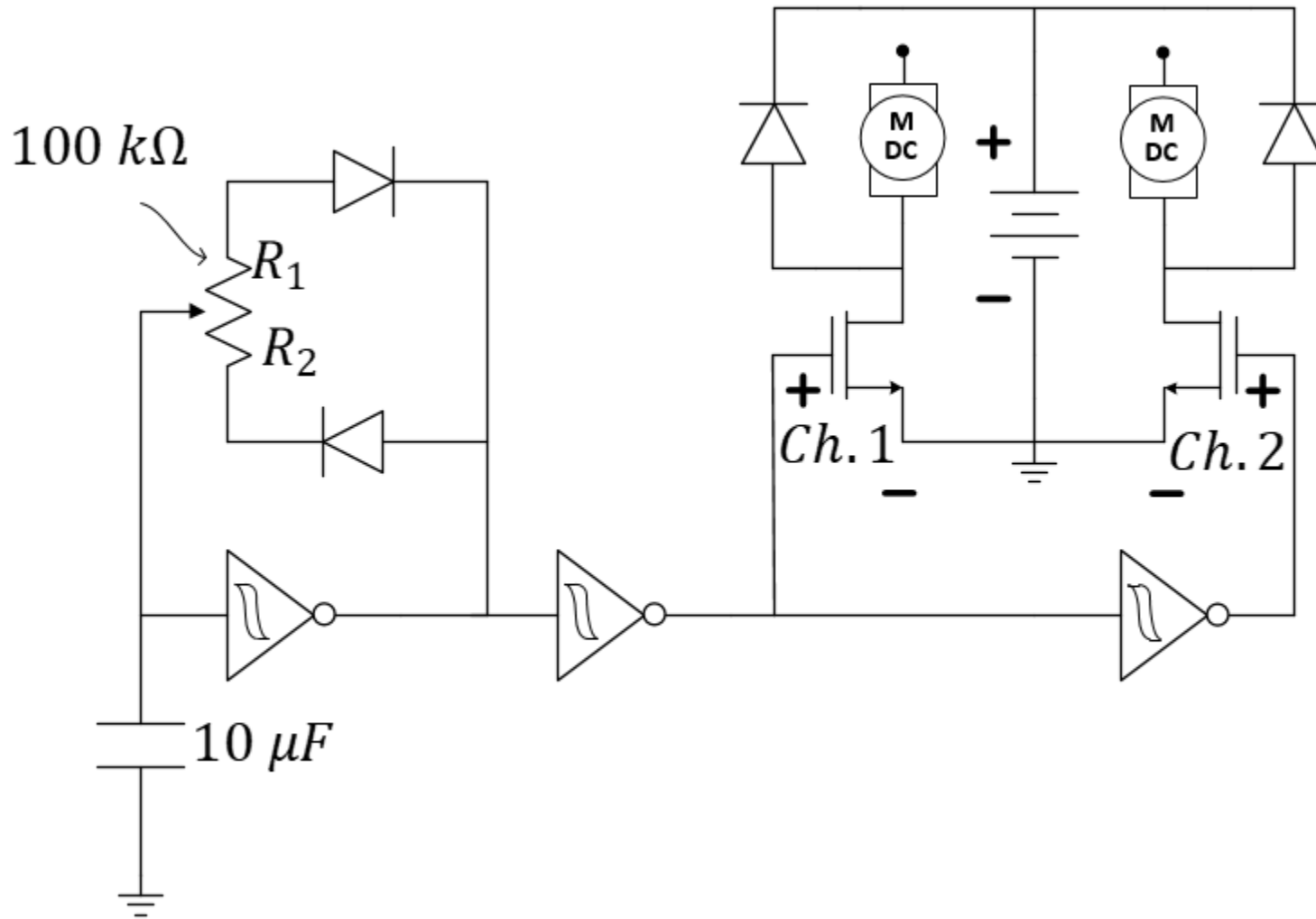

Figure 5: Disable the motors and use the oscilloscope to view and record the orthogonal outputs of the oscillator.

Notes:

The term **orthogonal** is derived from the Greek orthogonios ("ortho" meaning right and "gon" meaning angled).

Orthogonal concepts have origins in advanced mathematics, particularly linear algebra, Euclidean geometry and spherical trigonometry.

[What is orthogonal? - Definition from WhatIs.com](#)

Question 4: Use software to collect these waveforms. You will print them and include them with your next prelab.

Explore More! Modules

Explore More! Modules provide students with options to investigate new concepts! As time allows, do one or more of the modules before returning to the laboratory's core procedure.

This week, we highly recommend the following *Explore More! Modules*:

<i>Explore More! 8B The Clipping Circuit</i>	<i>Explore More! Schmitt Trigger IV</i>	<i>Explore More! Voltage-Follower Buffer</i>
--	---	--

Breakout Session #2



When called back to the breakout, work in teams of 8 to answer the Lab Summary questions.

Learning Objectives

- Use the running-motor model you determined prior, estimate the RMS current drawn by the motor at a known RMS voltage.
- Adjust your PWM signal to different duty cycles, make observations on the oscilloscope, save your data.

You are now ready to build a self-navigating vehicle. In the process, you have learned to model devices, predict behavior, build circuits, analyze circuit behavior, measure circuit parameters, and troubleshoot using the oscilloscope as a window into your work.

Lab 7 Summary (Prelude...Read this FIRST!)

Recall the moving-motor model you determined last week. That model was determined for DC voltages applied to the motor.

$$I = mV + b$$

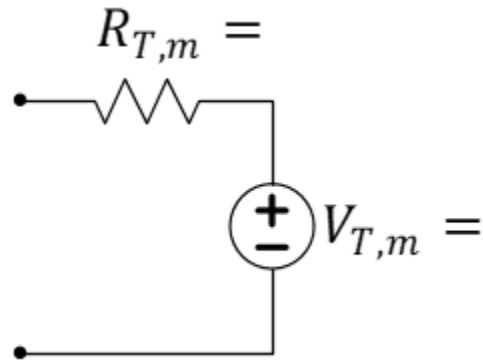

Figure 6: Recalling the Thevenin model of the moving motor.

Let's assume that when using PWM signals, we can exchange the model's DC voltage with the RMS voltage of the PWM signal. That is, we will assume

$$I_{rms} = mV_{rms} + b$$

is an accurate model for the motor using the same m and b found in the previous lab. Use this assumption to answer the lab summary questions.

Lab 7 Summary (To be submitted at the end of the laboratory session)

Question 5: What are your values of m and b from last week?

Question 6: What RMS current would we expect when driving the motor with a PWM signal of 40% duty cycle and a 0-to-peak amplitude of 7 volts?

Question 7: What RMS current would we expect when driving the motor with a PWM signal of 60% duty cycle and a 0-to-peak amplitude of 7 volts?

Question 8: Discuss with the other students alternative ideas for balancing the wheel speeds. Write one or more of those ideas below.

Notes:

Name:

NetID:

Section AB/BB:

0 1 2 3 4 5 6 7
8 9 A B C D E F

(circle one)

Bench:

A B C D E F G H I J K L M N O P

(circle one)

Return your borrowed equipment, clean up your benchtop, and submit your lab summary before leaving for the day. Thank you!

For TA use only:

- Prelab Check: full/half/zero credit
- Student was engaged throughout the lab, not distracted by phone, homework, etc.

TA initials: _____

TA initials: _____

Lab grade (reasons for deductions and/or total points awarded):

_____/6