

Name/NetID:

Teammate/NetID:

Section AB/BB:

0 1 2 3 4 5 6 7

8 9 A B C D E F

(circle one)

# Experiment 6: An Improved Motor Model (a shorter version for Fall 2018)

---

## Laboratory Outline: *Unit 1 Report is Due Now! Leave it with the Prelab.*

Up until this point we've used devices that can be treated as ideal for most practical purposes. Yet, even non-ideal devices are very practical in many applications and these will prove useful in your final design challenge as well as a host of projects you might take on after ECE 110. Motors and batteries are two such devices. As engineers, we must recognize non-ideal behavior and ask pertinent questions...Does a motor behave like a resistor? No, clearly our oscilloscope measurements revealed behaviors that are clearly not Ohmic. What is a better model? Can our battery provide enough current to drive two motors and the rest of the circuitry for any extended amount of time? You'll now understand some of the limitations of these devices when used in a circuit.

The DC power supply on your bench can be treated as an ideal voltage source for a great deal of its voltage range with typical circuits used in class. This is not the case with batteries. In the prelab, you characterized how our battery pack behaved under a load and you used a simple linear approximation of a battery that allows us to analyze this non-ideal device by modelling with a perfectly-linear IV curve.

Motors convert electrical energy into kinetic energy. Today we'll characterize the chassis motor by varying the voltage that is applied to the motor terminals. In addition, we'll develop a linear model that approximates the motor's behavior over a range of input voltages. This will simplify analysis for the motor-drive circuit.

START OF MODULE 100

Breakout Session... *Explore More! Module: 100: IV Characteristics*

Today, this is an Explore More! Module...please only finish if time allows!



Analytic Circuit Characterization through IV

In groups of 8, predict the IV equation for the circuit depicted in the schematic below.

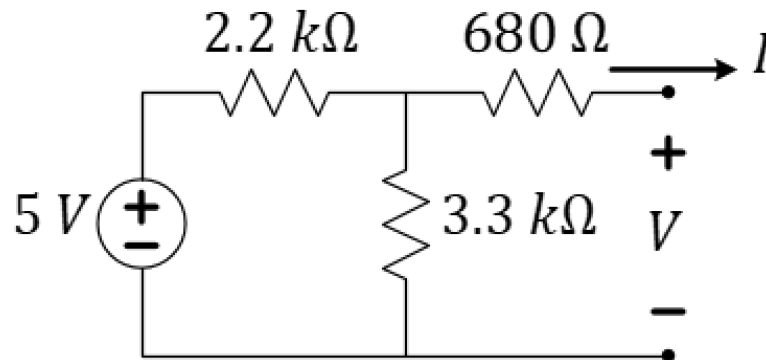

*Figure 1: You will find the IV characteristics of this circuit, first analytically, then by constructing it.*

**Question 1:** Provide the IV equation for the circuit above.  $I = mV + b$ , find  $m$  and  $b$ .

## At Your Bench

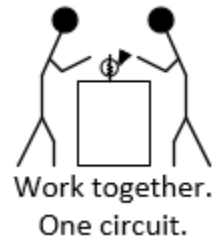

### Empirical Circuit Characterization through IV

Build this circuit using the power supply and resistors from your kit. In the next question, you will take IV data measurements to validate your formula.

**Question 2:** Take current and voltage measurements of your circuit under various loads,  $R_L$ , of your choosing. Use your resistor kit to provide the loads (Figure 2). If you apply Ohm's law and measure the resistances used for the load, you should not require the ammeter, but feel free to use it if you wish. Just make sure it is attached properly.

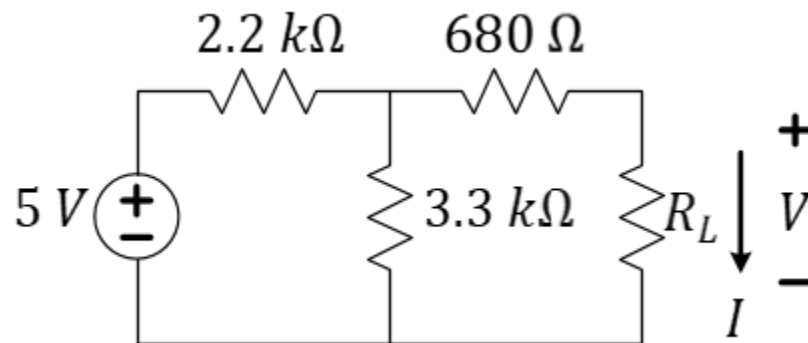

*Figure 2: Finding the IV characteristics of this circuit empirically.*

Notes:

$R_L [\Omega]$ measured	$V [volts]$ measured	$I [A]$ (calculated or measured?)	Comments

**Table 1:** Empirical determination of the current-voltage characteristics.

**Question 3:** Use a software (eg. MATLAB or Python) to plot your IV data and to apply a linear curve fit to it.

**Question 4:** From your linear curve fit, provide the empirically-determined IV equation for this circuit.  $I = mV + b$ , find  $m$  and  $b$ . You can apply a *1<sup>st</sup>-order polyfit* in the previous problem to get the slope and intercept of this equation.

%%%%%%%%%% END OF MODULE 100 %%%%%%%%%%

## Motor Characterization through IV

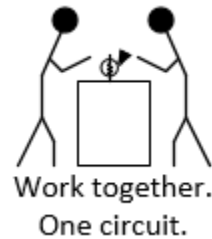

Today we'll look at the voltage-current relationship of a DC motor and see how it differs from resistors and develop a simplified linear model of the motor that we can use for basic circuit analysis.

Connect the circuit as shown in **Figure 3**, using the power (voltage) supply and one of the drive motors on your car.

- ✓ Make sure that the output on the power supply is set to "off" when you are constructing or making changes to your circuit. Use the + and - ports of the **+6V supply** on the HP3631A DC power supply.
- ✓ The DC motor in the diagram is one of the drive motors on your car chassis (not the extra DC motor in your ECE110 electronics kit). You do not need to remove the motor from the chassis. Instead, use the small wooden block as a "car lift" to keep the wheels off the ground.

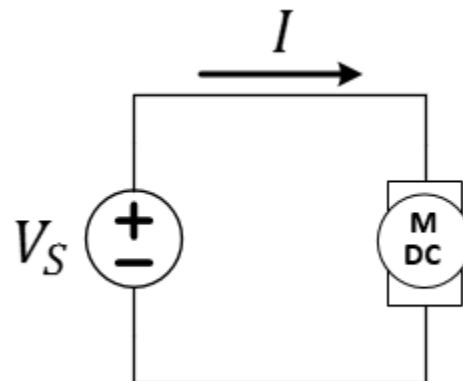

**Figure 3:** Circuit schematic of the variable voltage source motor drive method.

**Warning:** Do not apply more than 10 volts to your motor or you will risk permanent damage to it.

Run your motor at 6 volts for 2 minutes to warm it up. This should help you get more consistent results in your measurements.

Before we begin taking measurements using our motor, it's good practice to perform a quick test run with our circuit. In this case, we want to collect as many measurements as possible just before and just after the motor begins to turn (or stops turning).

Which voltage is larger? You will find that when the supply voltage is too low, the motor will remain stopped due largely to static friction and inertia. When the voltage is increased enough, the motor will turn on. Once the motor is moving and the voltage is decreased, the motor will not stop (stall) at the same turn-on voltage level because of the different *kinetic* friction and inertia. Starting from 0 V, the motor will fight internal friction. To find the turn-on voltage it is important that you always collect your data in with increasing voltage. If you need to go back and collect a certain data point, you need to start over from a voltage that produces a stalled position. Likewise, the stall voltage can only be found by starting from a higher voltage where the wheel is moving and reducing the voltage until the stall occurs.

When we **sweep the voltage from high to low**, kinetic friction of the motor is less than the static friction. The inductance of the motor windings may also play a role in keeping the motor rotating. Eventually, we will reach a stall voltage that is generally lower than the turn-on voltage.

**Question 5:** Starting at zero volts, sweep the voltage of the power supply up to 6V and make note of the approximate “turn-on” voltage at which the motor begins to spin. Once you have hit 6V, sweep the voltage back down and make another note of the approximate voltage at which the motor stops or “stalls”. Record your approximate turn-on and stall voltages here. These two numbers should be somewhat different.

Voltage (V)	Current	Notes:

**Table 2:** Current flow for the motor for *increasing, then decreasing*, DC voltage with comments.

**Question 6:** Use MATLAB or BenchVue to generate an automated sweep of the power supply. Start at zero volts and sweep the voltage of the power supply up to 6V.

**Question 7:** ~~Again, use MATLAB or BenchVue to generate an automated sweep of the power supply. Start at 6 volts and sweep the voltage of the power supply down to 0V.~~ **DELETED!**

**Question 8:** Use MATLAB or Python to generate a single graph of both sets of IV data ~~(two curves on one graph).~~

Notes:

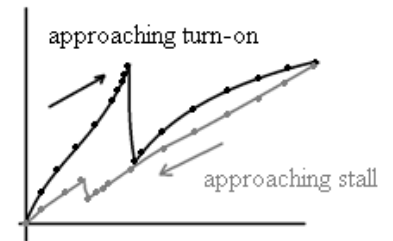

Example motor IV data without curve fits. Your figure may look quite a bit different.

Notes:

**Question 9:** Perform a linear curve-fit to the ~~6V to stall~~ moving portion of this data (labeled “while moving” on the image to the right). You may use a straight edge to draw your linear curve-fit on your printout. Alternately, in MATLAB, you might use the *polyfit* command to do a first-order ( $n=1$ ) fit to that data.

**Question 10:** Determine a linear equation (slope-intercept form) corresponding to ~~each~~ the linear curve-fit generated. Explain how you found the missing values below.

While Moving:  $I = \underline{\hspace{2cm}} V + \underline{\hspace{2cm}}$

While Stalled:  $I = \underline{\hspace{2cm}} V + \underline{\hspace{2cm}}$  ~~DELETED!~~

**Question 11:** Using this equation, determine a Thevenin-equivalent circuit for your motor to model it when it's moving.

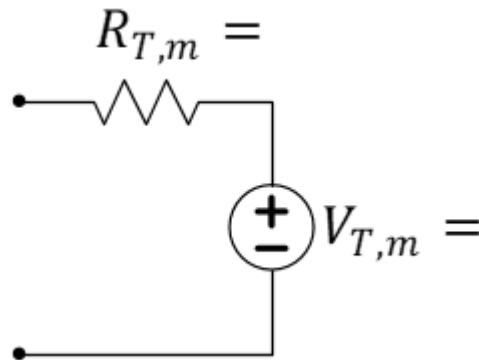

**Figure 4:** Record your estimates of  $R_{T,m}$  and  $V_{T,m}$  for the Thevenin model of the moving motor in the figure above.

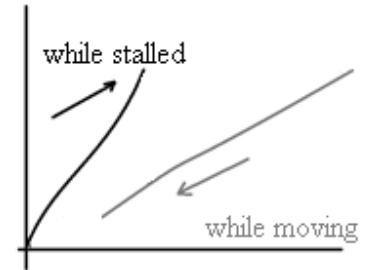

Example motor IV data showing the two portions where you should perform curve fits.

## Explore More! Modules

Explore More! Modules provide students with options to investigate new concepts! As time allows, do one or more of the modules before returning to the laboratory's core procedure.

This week, we highly recommend the following **Explore More! Modules**:

<b>Explore More! 6D: Using the Arduino to Drive Vehicle</b>	<b>Explore More! 7B: Interfacing Resistive Sensors Digitally</b>	<b>Explore More! The Burglar Alarm</b> <b>Explore More! 100: IV Characteristics</b>
---	--	--

## Breakout Discussion Session



When called back to the breakout, work in teams of 8 to answer the Lab Summary questions.

## Learning Objectives

- Measure, analyze, and model the IV characteristics of the motor, noting that hysteresis (different behaviors in two different stimulus directions) requires two Thevenin models.
- Make note of the current drawn by the motor in normal operation and at a stall point.
- Estimate the waste power (large percentage!) for an inefficient voltage-divider-style motor speed controller.

You should now know how to think about circuits that include both batteries and motors as you now understand several limitations of these devices when used in a circuit. You have seen that models can help us produce accurate estimates of the actual performance of these devices. Motors and batteries are a central part of our future experiments and will be necessary for the final design project.



## Lab 6 Summary (To be submitted at the end of the laboratory session)

**Question 12:** How much power is drawn from the power supply just below the turn-on voltage (while still stalled)?

See the operating point suggested in the image on the right.

**Question 13:** When stalled, all energy from the battery is wasted. How long will your battery last if it were to sit continuously *just below* the turn-on state? **Recall that the battery is rated at 1900 mAh. You measured the current drawn just below turn-on!**

**Question 14:** ~~Comment on the linearity of the motor's moving and non-moving I-V data.~~ **DELETED!**

**For TA use only:**

- Prelab Check: full/half/zero credit
- Student was engaged throughout the lab, not distracted by phone, homework, etc.

TA initials: \_\_\_\_\_

TA initials: \_\_\_\_\_

Lab grade (reasons for deductions and/or total points awarded):

\_\_\_\_\_ /

Notes:

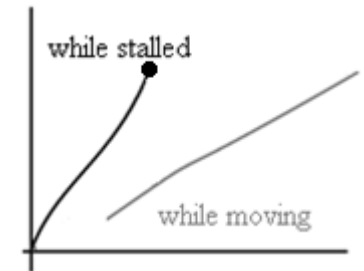

The stall point will draw a large amount of power from the battery!

Name:

NetID:

Section AB/BB:

0 1 2 3 4 5 6 7  
8 9 A B C D E F

(circle one)

Bench:

A B C D E F G H I J K L M N O P

(circle one)

Return your borrowed equipment, clean up your benchtop, and submit your lab summary before leaving for the day. Thank you!