

Pre-lab 6: Modeling Your Battery

Review: Thevenin Equivalent Circuit

At this point we should all be familiar with solving circuits containing sources and resistors using KVL and KCL. It is beneficial to know that there are other very powerful tools to analyze circuits. One of these tools is the Thevenin Equivalent Circuit. The theory of Thevenin Equivalent Circuit starts with a black box with 2 terminals. **Black box** is a term used for *a device with unknown construction*. It refers neither to the color or enclosure! Assume this black box only contains ideal sources and resistors. However, you have no information on how many sources and resistor are present, nor do you know the values of these components. Thevenin's theory, can transform a circuit, as viewed through two terminals, into a Thevenin Equivalent Circuit. A Thevenin Equivalent circuit is an ideal voltage source in serials with a resistor. By applying the Thevenin's theory, you can actually find a simple *equivalent* circuit for the circuit composed by the black box. An equivalent circuit is a circuit that functions identically to the original circuit. Any circuit that performs mathematically-equivalently to another circuit is considered an *equivalent* to that circuit.

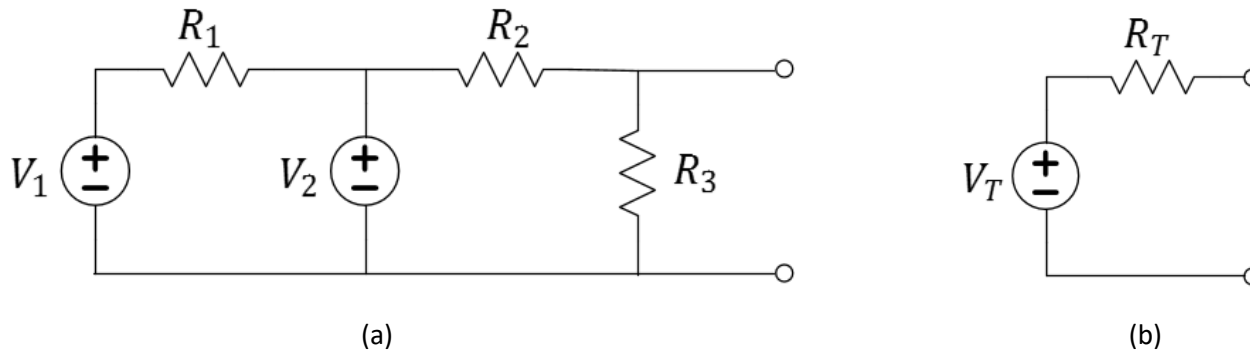

Figure 1: A complex DC circuit (a) and the Thevenin Equivalent Circuit (b) to which all DC circuits can be reduced.

In order to find V_T , open the two terminals and measure the open-circuit voltage (connect a voltage meter to the two terminals).

In order to find R_T , short the two terminals and measure the short circuit current I_{sc} , then apply Ohms law. $R_T = \frac{V_T}{I_{sc}}$.

Section AB/BB:

0	1	2	3	4	5	6	7
8	9	A	B	C	D	E	F

(circle one)

Thevenin's theory reduces the circuit into one equivalent voltage source V_T and one equivalent resistor R_T .

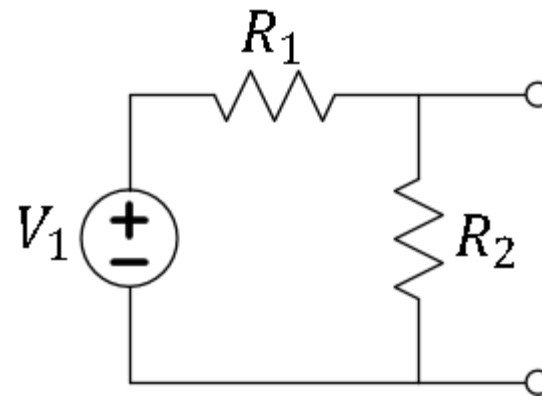
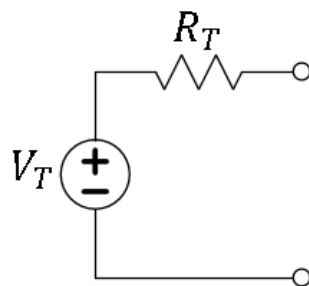

Figure 2: A practice circuit.

Question 1: For the practice circuit in Figure 2, find the Thevenin Equivalent Circuit when $V_1 = 5\text{ V}$, $R_1 = 2.2\text{ k}\Omega$, and $R_2 = 3.3\text{ k}\Omega$.



$V_T =$

$R_T =$

Figure 3: The Thevenin equivalent of the practice circuit.

When given a circuit containing voltage sources, current sources, and resistors, it is possible to determine the Thevenin equivalent circuit using circuit analysis methods. Most real devices are not so simple, so we use empirical methods to determine the Thevenin equivalent circuit. In particular, we'll use graphical analysis of a device's IV curve.

Consider the IV curve of a resistor. The "curve" roughly follows the equation of a line. The slope of that line is equal to the inverse of the resistance as expressed by Ohm's Law. Many devices that are not resistors (combinations of ideal resistors, voltage sources and current sources) will also produce **linear** IV characteristics. The slope of the IV line is the inverse of the *Thevenin resistance*. In addition, the open-circuit voltage of these kinds of circuits will provide the value of the voltage of the Thevenin-equivalent voltage source (open-circuit forces the current to be equal to zero). In many cases, the IV curve is not perfectly linear (devices do not follow our simple models) but we can still approximate the Thevenin circuit by conducting a linear curve-fit over fixed ranges of data.

Non-ideal Voltage Source

Earlier in this course, we found the DC power supply to behave nearly as an ideal voltage source. For most practical applications, however, the use of a power supply is prohibitive as the DC power supply is too large and requires a wall outlet making it less-than-mobile. Batteries provide a versatile option, but we must understand their non-ideal behaviors. Batteries present an engineering tradeoff. While they are less-than-ideal as a constant-voltage source, they can be made small and portable. What do we engineers do with this tradeoff? We figure out how to make the best of it by modeling the non-ideal behavior of the battery and accounting for it in our designs.

Let's begin by considering a very simple linear model of a battery, the Thevenin equivalent circuit. In this model, we assume that the battery is equivalent to an ideal voltage source (V_B) and source resistance (R_B) in series. In this prelab, we'll explore this model further by using DMM measurements (premeasured by your instructor) to determine appropriate values of V_B and R_B .

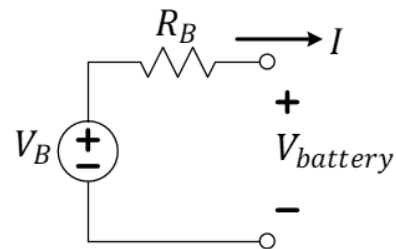

Figure 4: A first-order battery (Thevenin-equivalent) model.

Think about it: For a circuit consisting of a simple resistor with resistance R , the Thevenin resistance is $R_T = R$. What would be the Thevenin voltage for the equivalent circuit? What would be the Norton current when considering the Norton equivalent circuit?

Notes:

Below, we are providing you with a table of real-life measurements from the 6-pack of 1.2-volt, AA-sized, NiMH batteries used in the laboratory. It will be your task to plot the data and to estimate the internal resistance (according to a Thevenin model) in the region where the battery is not severely loaded (forced to source a lot of current).

Current (mA)	Voltage (V)	Comments
0.0006	8.837	Using a potentiometer to control current via Ohm's Law. We did not record the resistance setting, but only the current and voltage. Voltmeter measures the voltage; Ammeter measures the current.
87.99	8.772	
93.60	8.759	
131.5	8.707	
148.9	8.688	
188.8	8.688	
215.2	8.627	
215.2	8.627	
258.4	8.586	
347.7	8.514	As the voltage dropped below 8 volts during the experiment, the current went to 800 mA, but then decreased wildly as the battery was forced well outside of its "linear" mathematical behavior!
534.9	8.375	
800	7.99	

Table 1: IV data collected for the battery by the instructors. This is from one specific battery and not necessarily average for what might be expected.

Question 2: Plot the IV curve of a battery using the real-life data of Table 1. You should use MATLAB or Python and fit a linear curve to the data (it is acceptable to use a pencil for the curve fit but doing it in software is preferred). Attach your graph to this assignment.

Question 3: Determine the Thevenin equivalent circuit of the battery using your linear curve-fit and draw the equivalent circuit below. Label it as Figure 5. Explain the process of finding the Thevenin values.

Think about it: In general, this battery model is very useful but it does not the battery when it has mostly discharged (died). As the battery dies, its internal resistance grows and it deviates from the ideal voltage very quickly. In order to avoid this, it is important to keep our batteries regularly charged using a safe value charging current.

Power and Energy

Batteries are devices that store electrical energy typically by either exploiting a chemical process. In a circuit schematic, sources of electrical power can be distinguished from power sinks (or loads) by the relationship between the polarity of the voltage across the device and the polarity of the current flowing through it.

$$P = VI$$

Or, more specifically, if $V_{+\rightarrow-}$ is the voltage drop across a device in the direction of the current's polarity arrow:

$$P_{device} = V_{device} \times I_{device} = V_{+\rightarrow-} \times I_{\rightarrow} \text{ which is } \begin{cases} < 0 \text{ if power source} \\ > 0 \text{ if power sink} \end{cases}$$

Power and energy are two related concepts often confused by the aspiring engineer. Often energy is first learned in the potential and kinetic forms. It is conserved in that it is neither created nor destroyed, but instead may incur transformations in form. It has units of joules (J). A charge-storing device, like a battery or a capacitor, is often referenced by the amount of energy it stores. A device that utilizes energy for long periods of time, like a light bulb, are often referenced by the amount of energy they utilize each second. Power is the amount of energy expended over time. It has units of Watts (1 Joule/sec). In this way, a 60-Watt incandescent bulb transforms 60 Joules each second into light and heat.

You have been supplied with a rechargeable 7.2-V (6 times 1.2V per battery) Nickel Metal Hydroxide (NiMH) battery with a 1900 milliamp-hour (mAh) rating. While this is a charge rating, Q , a little reasoning soon leads us to see that the battery might deliver 1900 milliamps at 7.2 volts while running continuously for 1 hour and thus it also provides an energy rating. Since milliamps are a measure of the maximum electron flow (coulombs/second), the battery might alternately deliver 1 milliamp for 1900 hours (79 days). Significant variations between batteries will occur due to deviations in manufacturing, the age, and current-supplying limitations imposed by the materials comprising the battery (in this case, NiMH). Later, we will find that the two motors used in our car project consume a large majority of the overall circuit power and we can use this fact to estimate the battery life when we reach full testing and demonstrations later in the semester.

Charging the Battery

It is important not to attempt to charge a battery faster than the chemical reaction can comfortably occur. For NiMH batteries, the suggested charging rate is from $0.5 \times C$ to $1.0 \times C$, where C is the energy rating designated on the battery in mAh. Since our battery is rated at 1900 mAh, a 1-amp maximum charging current should be a good, safe choice.

Question 4: Calculate how long the battery should charge if it were completely dead before charging continuously at 1.0 A. Assume that the battery has a charging efficiency of 66% (66% of the total current goes toward charging increasing the potential energy of the battery while the rest is wasted, perhaps as heat).

Question 5: State the conservation of energy equation ($E_{input} = \Delta E_{state} + E_{waste}$) as it applies to charging the battery. Give numeric values in Joules for the energy input, change in state, and waste.

Using Circuit Models

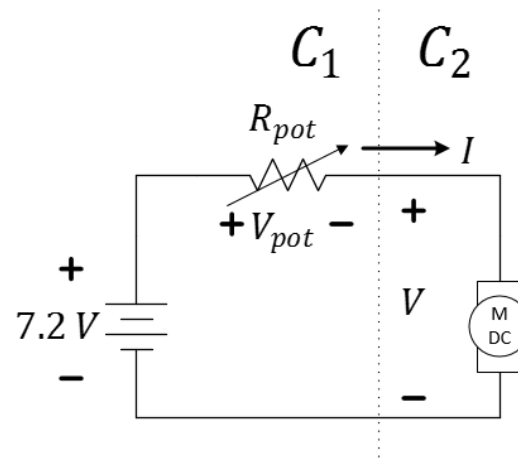

Figure 6: Current-limiting circuit for the motor.

Question 6: Replace the battery of Figure 6 with the Thevenin model, V_B and R_B (recall Figure 4). Find the IV equation of circuit C_1 as a function of V_B , R_B , and R_{pot} .

$$I_1 = mV_1 + b = \quad V_1 +$$

Question 7: Using your modeled values from **Question 3** for V_B and R_B , simplify your formula to give the IV equation as a function of R_{pot} only.

$$I_1 = mV_1 + b = \quad V_1 +$$

In lab, IV measurements will be made of the motor so that Thevenin modelling can be applied to the motor, circuit C_2 , as well.

Question 8: Don't forget...The Unit 1 Report is due with this prelab!

Learning Objectives

- Review Thevenin Theory
- Find Thevenin-equivalent models through curve-fitting real data; scientific computing using MATLAB or Python.
- Extract information from datasheets.
- Reconcile conservation-of-energy equations.
- Apply Thevenin-equivalent-circuit theory to the lab.
- Prepare for lab by finding the IV characteristic equation of the battery in series with a current-limiting potentiometer.