

LM311 Comparator

Laboratory Outline

A comparator allows two voltages to be compared. When voltage **IN+** exceeds voltage **IN-**, the output jumps up to the battery supply voltage value. When voltage **IN+** falls below voltage **IN-**, the output voltage drops quickly to the ground voltage. In this exercise, you are provided guidance to build the comparator. You are then asked to build a peak-detector circuit with less guidance. We hope you are up for a challenge!

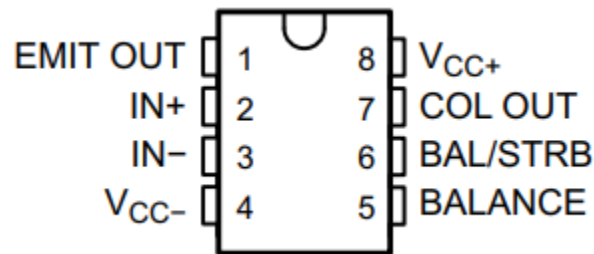

Figure 1: Pinout of the LM311 Comparator (source: Datasheet).

Prerequisites

- Breadboarding experience.
- Use of an oscilloscope.
- An adventurous spirit!

Parts Needed

- (1) battery, preferably near 9 volts **OR** you can use the benchtop power supply with the +25V supply set to 9 V
- (1) variable voltage source (6 volt or more capability)
- Function generator and oscilloscope
- Other components:
 - (1) LM311 comparator IC,
 - (1) 1 k Ω resistor,
 - (1) 10 k Ω potentiometer (for voltage divider, the actual value is not really important) **OR** you may use a variable DC voltage source (perhaps the +6 V supply from your benchtop equipment).

Learning Objectives

- To gain practical experience in circuit building and use of a comparator.
- To improve oscilloscope skills.
- To explore two other applications of the comparator.

Resources

Datasheet: <https://www.ti.com/lit/ds/symlink/lm311.pdf>

Datasheet

What are the limits on the power supplies for the LM311 comparator?

Voltage Comparator

Figure 2 is a stylized view of a comparator. It is stylized in that it ignores details like how to power the device or the fact that the inputs and outputs are voltage signals.

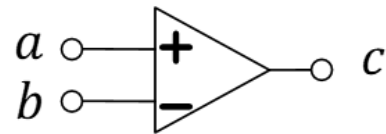

Figure 2: A stylized view of a comparator.

The comparator is a relatively easy-to-use IC that compares two voltages. The *digital* output, c , is either high (when input $a > b$) or low (when input $a < b$). Here, a and b are voltages (any value between 0/GND and the battery voltage, V_S). The digital voltage c is either exactly 0/GND or exactly the battery voltage, V_S . In a real circuit, the LM311 IC must be connected to power and ground (not shown in Figure 2). Furthermore, the output stage of the LM311 is essentially a NPN BJT transistor that requires an external R_C tied to battery power and an emitter tied to ground to operate. You might find Figure 9 of the datasheet (see [Resources](#)) particularly interesting for this project. The Balance and Bal/STRB pins of the LM311 need *not* be attached. The output voltage between the collector and emitter pins of the BJT, V_{CE} , is actually what is meant by c in Figure 2 while a and b are called IN+ and IN-.

Figure 3 is a more-realistic circuit-schematic representation of the LM311.

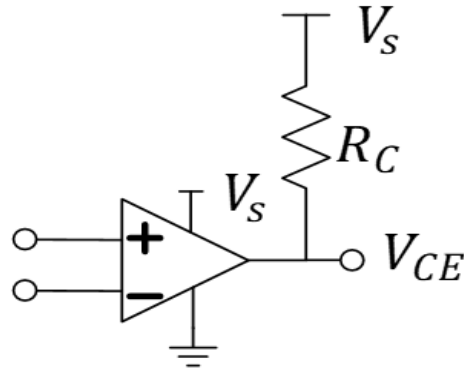

Figure 3: A realistic circuit schematic view of a functional LM311 comparator IC. The emitter (not shown) and the “negative” power pins are both tied to ground.

Often, the input to the non-inverting input terminal (+) is compared to a fixed voltage at the inverting input terminal (-) which is preset using a potentiometer as a voltage divider.

Using Figure 3 as a guide, build the voltage comparator with a potentiometer-based voltage divider applied to the inverting terminal. Select $R_C = 10\text{ k}\Omega$. Attach the function generator the non-inverting input with a 2 volt peak-to-peak sinusoid (high-Z mode) at 1 kHz and a 1 volt offset voltage. Use three channels of your oscilloscope to simultaneously view the two inputs and the one output node of Figure 3.

Question 1: Provide a screenshot of the oscilloscope showing the three voltages, **IN+**, **IN-**, **COL OUT**.

Question 2: Discuss the operation of the voltage comparator in your own words using the oscilloscope screenshot as a reference.

Question 3: Look at the datasheet of the LM311 (especially the later figures) and list two circuits based on the LM311. Then, as needed, do an Internet search to find out more about what application(s) each of those circuits would be useful.

Appendix

Can an Op Amp be used as a Comparator? The answer is a simple, “maybe.” You can view the “Application Note” entitled *Using Op Amps as Comparators* by James Bryant at <https://www.analog.com/media/en/technical-documentation/application-notes/AN-849.pdf>. He outlines pros and cons of using an Op Amp in this service. He recognizes it is possible and may work in some applications with good design and the right choice of Op Amp, but largely outlines issues in stability (unintended feedback that could cause oscillation) that leads him to this one simple statement:

However, the best advice on using an op amp as comparator is very simple—don’t!

That being said, if you need a comparator and all you have is an Op Amp, go for it and hope for the best!