

11/08/19

# Seeing is Believing: Generating and Detecting Fakes



Bernadette by Stephen Molyneaux



<http://www.flickr.com/photos/kjmeow/2320759046/>

Computational Photography

Derek Hoiem, University of Illinois

# Kinds of fakes

- Synthetic images
- Manipulated images
  - Photoshop
  - Image-based relighting, etc.
- Deep fakes

## Danger Level

**Yellow:** Hard to make, easy to detect automatically

**Orange:** Easy to make for images, hard for video; harder to detect automatically

**Red:** Very easy to make for images or video; hard to detect automatically

# CG vs. Real: Can you do it?

- <http://area.autodesk.com/fakeorfoto/>
- I can't! (I got 2/10 this time)

# CG vs. Real -- Why It Matters: Crime

- 1996 Child Pornography Prevent Act made certain types of “virtual porn” illegal
- Supreme court over-ruled in 2002
- To prosecute, state needs to prove that child porn is not computer-generated images



Real Photo

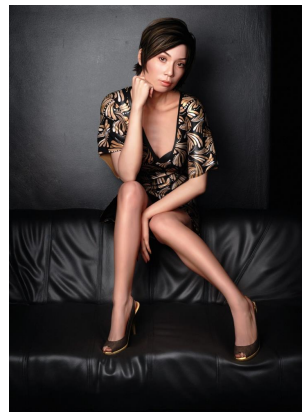

CG

# Automatically Detecting CG

- Sketch of approach
  - Intuition: natural images have predictable statistics (e.g., power law for frequency); CG images may have different statistics due to difficulty in creating detail
  - Decompose the image into wavelet coefficients and compute statistics of these coefficients

# 2D Wavelets

Kind of like the Laplacian pyramid, except broken down into horizontal, vertical, and diagonal frequency

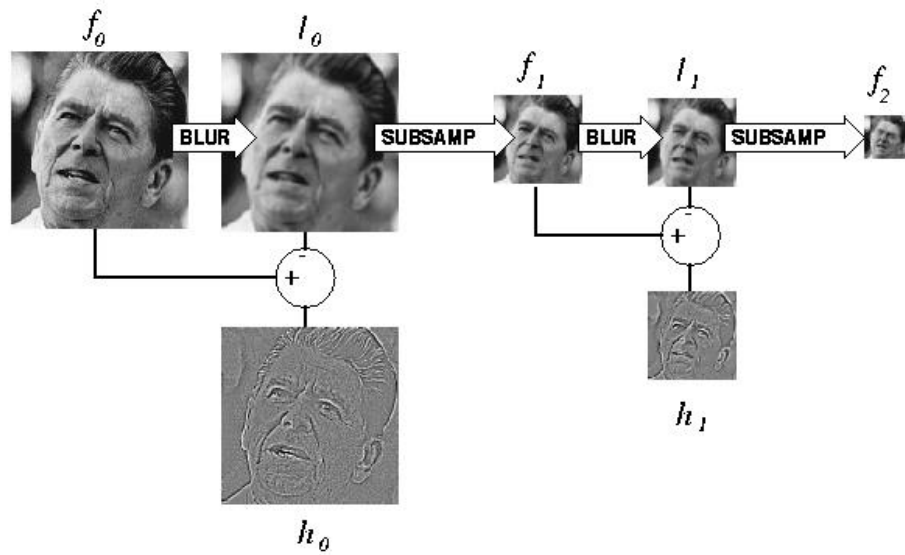

Laplacian Pyramid

L1 LL	L1 HL	Level 2 HL	Level 3 HL
L1 LH	L1 HH		
Level 2 LH		Level 2 HH	
Level 3 LH		Level 3 HH	

Wavelet Pyramid

# 2D Wavelet Transform

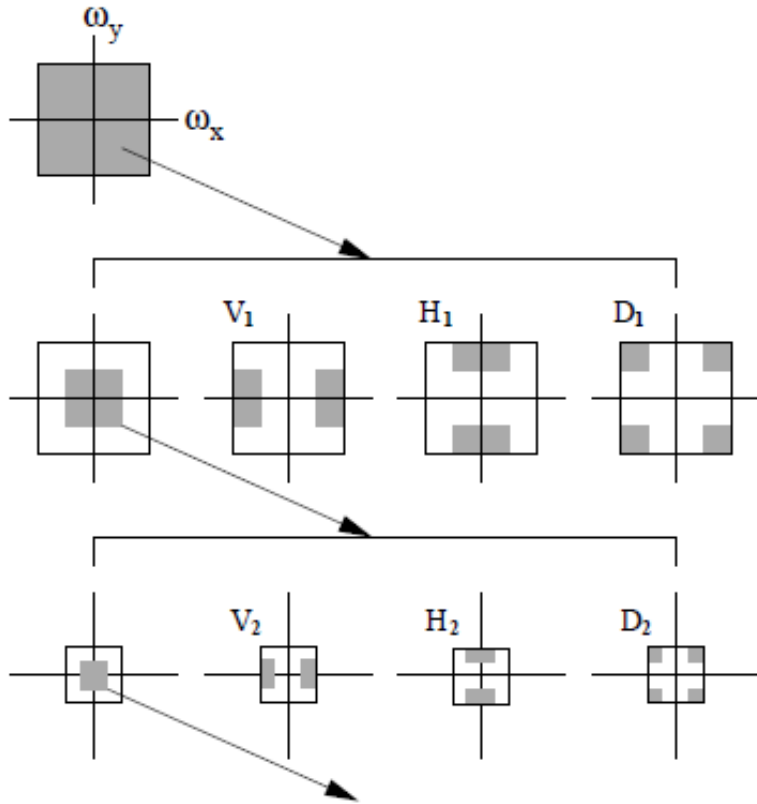
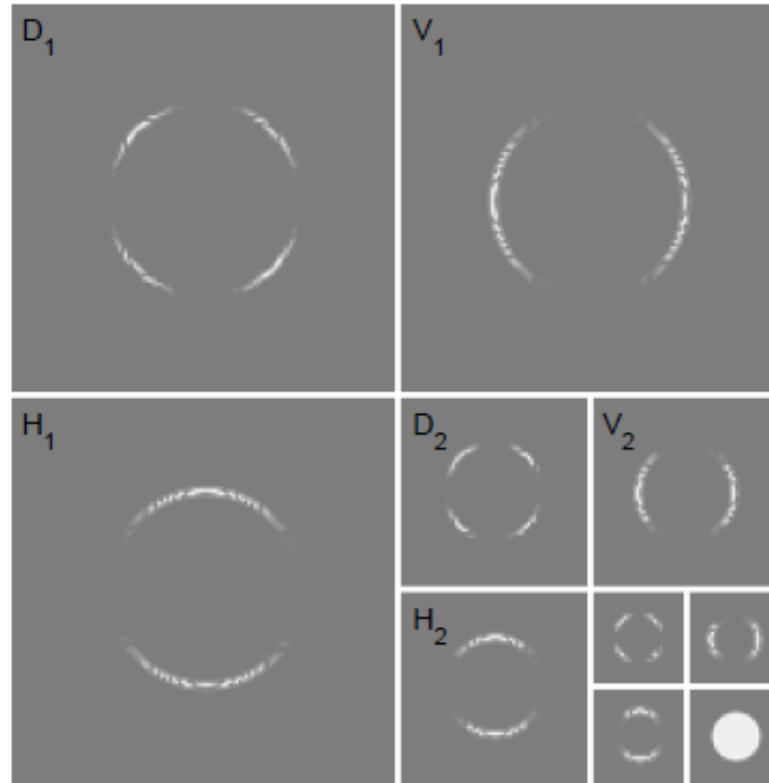

Illustration of procedure



Wavelet decomposition of disc image

# Automatically Detecting CG

- Sketch of approach
  - Intuition: natural images have predictable statistics (e.g., power law for frequency); CG images may have different statistics due to difficulty in creating detail
  - Decompose the image into wavelet coefficients and compute statistics of these coefficients
  - Train a classifier to distinguish between CG and Real based on these features
    - Train RBF SVM with 32,000 real images and 4,800 fake images
    - Real images from <http://www.freefoto.com>
    - Fake images from <http://www.raph.com> and <http://www.irtc.org/irtc/>



# Results

- 98.8% test accuracy on real images
- 66.8% test accuracy on fake images
- 10/14 on fakeorfoto.com

# Results

- Fake-or-photo.com: Correct

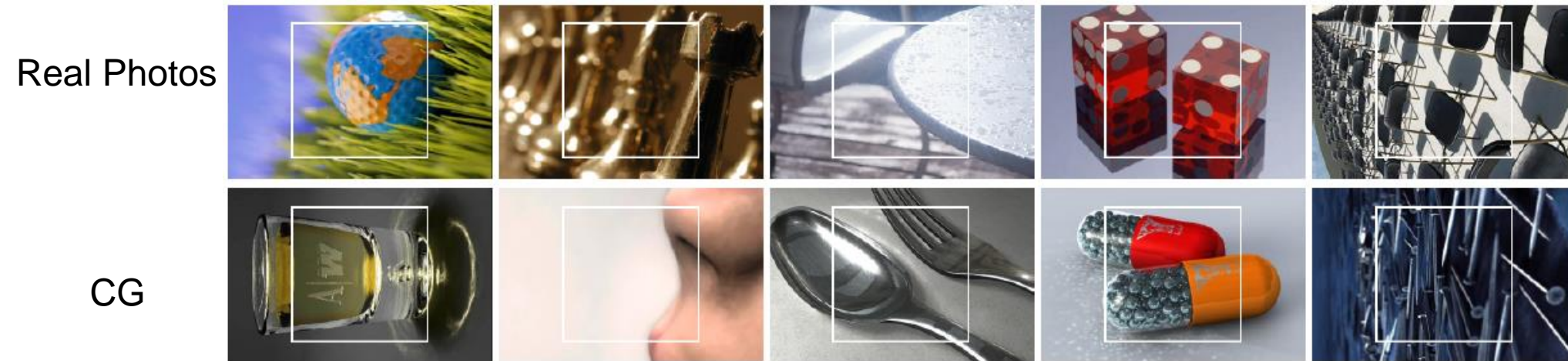

Lyu and Farid 2005: “How Realistic is Photorealistic?”

# Results

- Fake-or-photo.com: Wrong

Real photos  
misclassified  
as CG

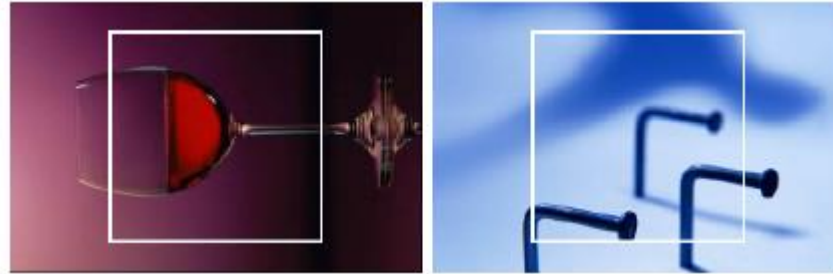

CG  
misclassified  
as real photos



Lyu and Farid 2005: “How Realistic is Photorealistic?”

# Detecting Forgery -- Why It Matters: Trust

Examples collected by Hany Farid: <http://www.fourandsix.com/photo-tampering-history/>



Iconic Portrait of Lincoln (1860)

“While photographs may not lie,  
liars may photograph.”

Lewis Hine (1909)

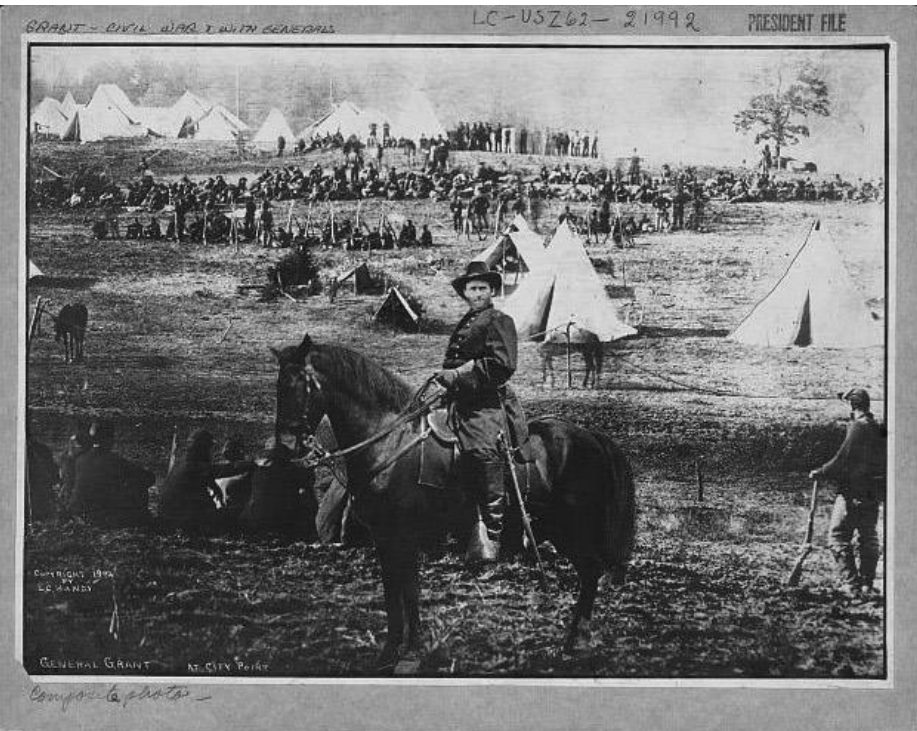

General Grant in front of Troops (1864)



Mussolini in a Heroic Pose (1942)



1950: Doctored photo of Senator Tydings talking with Browder, the leader of the communist party, contributed to Tydings' electoral defeat





Gang of Four are removed (1976)



1989 composite of Oprah and Ann-Margret (without either's permission)



Photo from terrorist attack in 1997 in Hatshepsut, Egypt

## Fonda Speaks To Vietnam Veterans At Anti-War Rally



Actress And Anti-War Activist Jane Fonda Speaks to a crowd of Vietnam Veterans as Activist and former Vietnam Vet John Kerry (LEFT) listens and prepares to speak next concerning the war in Vietnam (AP Photo)

Caption: "Actress and Anti-war activist Jane Fonda speaks to a crowd of Vietnam veterans, as activist and former Vietnam vet John Kerry listens and prepares to speak next concerning the war in Vietnam." (AP Photo)



Kerry at Rally for Peace 1971



Fonda at rally in 1972



2005: USA Today SNAFU





2006: Photo by Adnan Hajj of strikes on Lebanon (original on right)  
Later, all of Hajj's photos were removed from AP and a photo editor was fired.



2007 Retouching is “completely in line with industry standards”



The French Magazine Paris Match altered a photograph of French President Nicolas Sarkozy by removing some body fat. (2007)





Claimed Photo



Poster



Overlay

2007: Zhou Zhenglong claimed to take 71 photos of the nearly extinct South China tiger



Similar scandal in 2011 from Terje Helleso who won Swedish Env. Prot. award



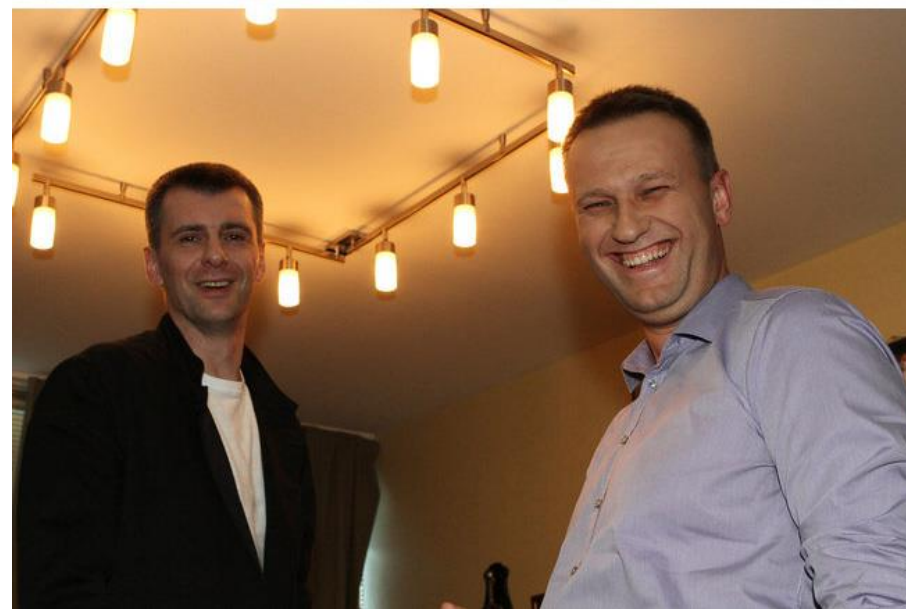

(2012) A Russian newspaper distributed by a pro-Kremlin group printed a photograph showing blogger/activist Aleksei Navalny standing beside Boris A. Berezovsky, an exiled financier being sought by Russian police.



2008



“Evidence” that Malaysian politician Jeffrey Wong Su En was knighted by the Queen (2010)





Cloning sand to remove shadow. Miguel Tovar – banned from AP, all his photos removed (2011)



Photo from Korean Central News Agency, determined to be composite (people don't appear wet) – was attempt to get sympathy for North Korea to get more international aid





2013: fake floors, counter, appliances digitally added for listing in Luis Ortiz's show "Million Dollar Listing New York"





A farmer from Hunan province, China was sentenced to 12 years in prison and fined 500,000 yuan after receiving 453,00 yuan (US\$73,000) in blackmail payments out of an attempted 9.47 million yuan. He had mailed to more than 200 officials pornographic photos into which he had inserted them using photo editing software. He threatened to publicize the photos unless he was paid. One of the victims claimed that he made the demanded payment before he “sensed later on that the man inside the photo was actually not me.”



Nov 2014: Russian state media ran a story with “proof” that a Ukrainian jet shot down the Malaysian airlines plane. Photo is composed of Google Earth imagery, Yandex maps, and a stock photo of a Boeing jet.

# Detecting forgeries

- Work by Hany Farid and colleagues
- Method 1: 2D light from occluding contours



# Estimating lighting direction

## Method 1: 2D direction from occluding contour

- Provide at least 3 points on occluding contour (surface has 0 angle in Z direction)
- Estimate light direction from brightness

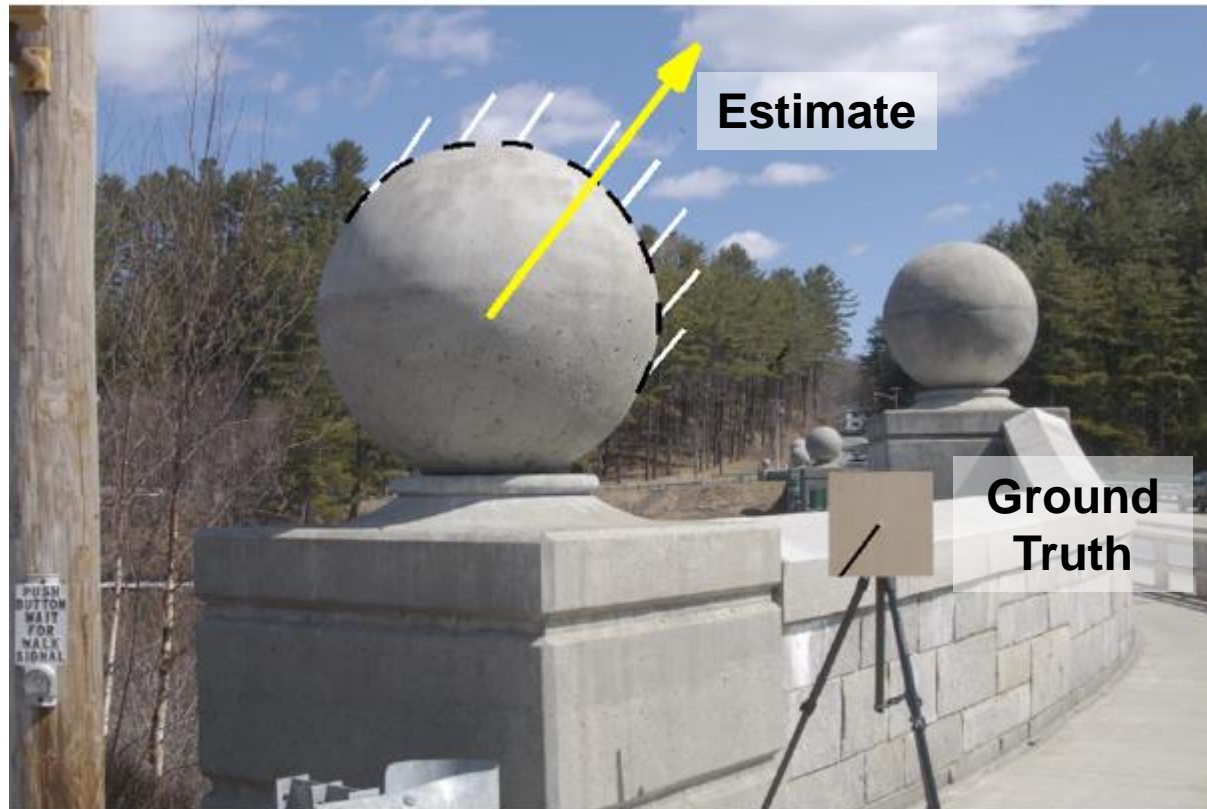



# Estimating lighting direction



# Estimating lighting direction

- Average error: 4.8 degrees



# Method 2: Light from Eyes



Farid – “Seeing is not believing”, IEEE Spectrum 2009

# Estimating Lighting from Eyes

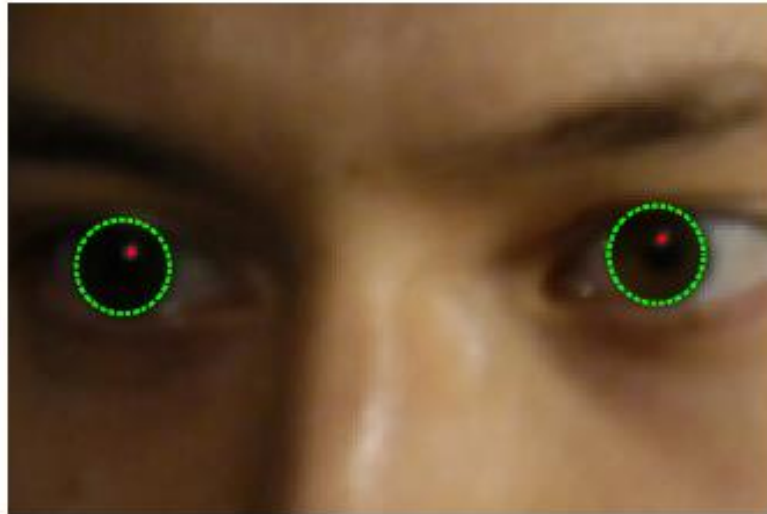



# Method 3: Complex light with spherical harmonics

- Spherical harmonics parameterize complex lighting environment
- Same method as occluding contours, but need 9 points

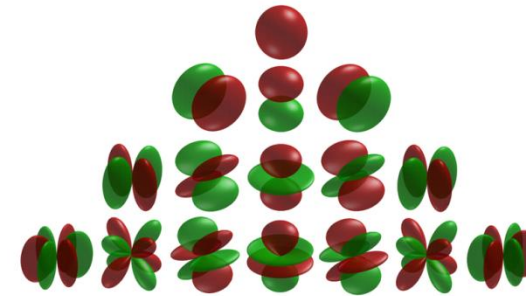

# Method 3: Complex light with spherical harmonics

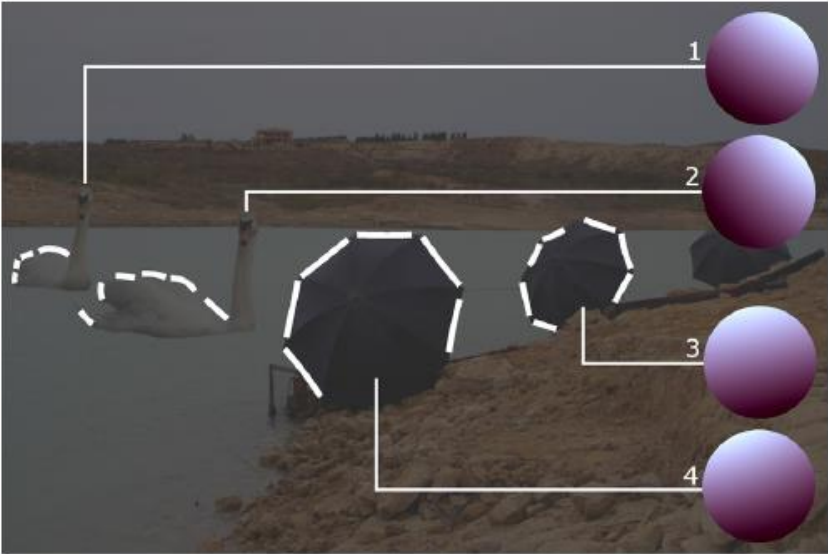

# Method 4: Demosaicking Prediction

- In demosaicking, RGB values are filled in based on surrounding measured values
- Filled in values will be correlated in a particular way for each camera
- Local tampering will destroy these correlations

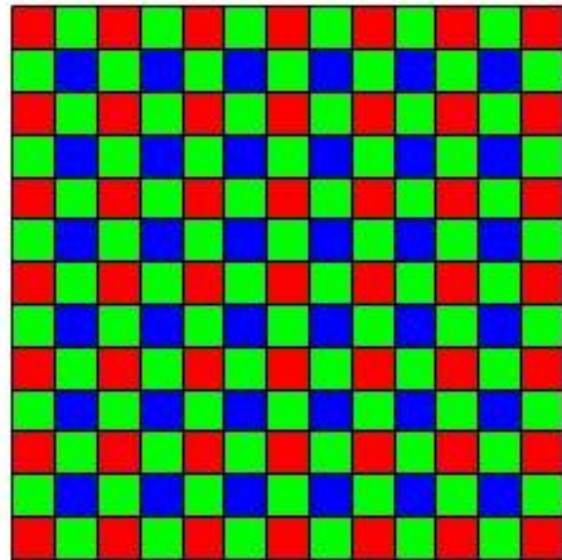

**Bayer filter**

Farid: "Photo Fakery  
and Forensics" 2009



# Demosaicking prediction

- Upside: can detect many kinds of forgery
- Downside: need original resolution, uncompressed image

Original



Tampered

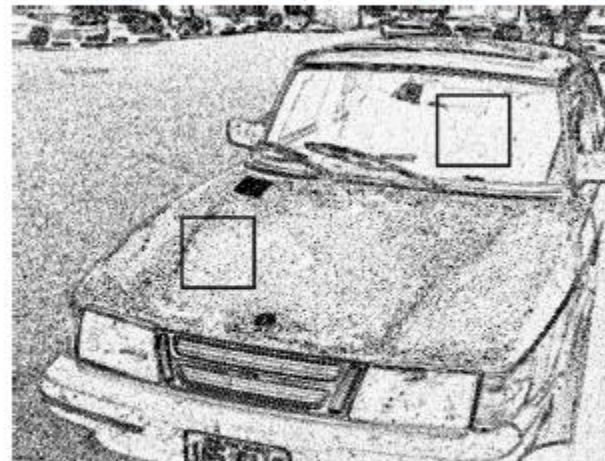

Error in pixel prediction from a linear interpolation

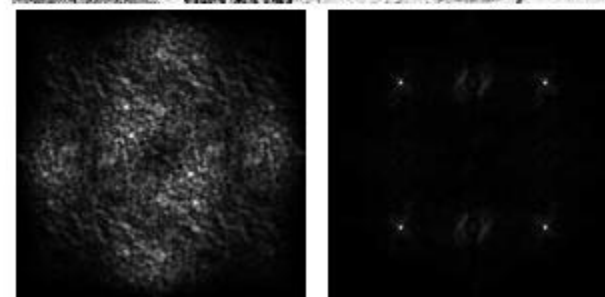

FFT of error in each window (periodic for untampered case)

# Method 5: JPEG Ghosts

- JPEG compresses 8x8 blocks by quantizing DCT coefficients to some level
  - E.g., coefficient value is 23, quantization = 7, quantized value = 3, error =  $23-21=2$
- Resaving a JPEG at the same quantization will not cause error, but resaving at a lower *or higher* quantization generally will
  - Value = 21; quantization = 13; error = 5
  - Value = 21; quantization = 4; error = 1

# JPEG Ghosts

- Original is saved at 85 quality, center square is cut out and compressed at 65 quality; then image is resaved at given qualities

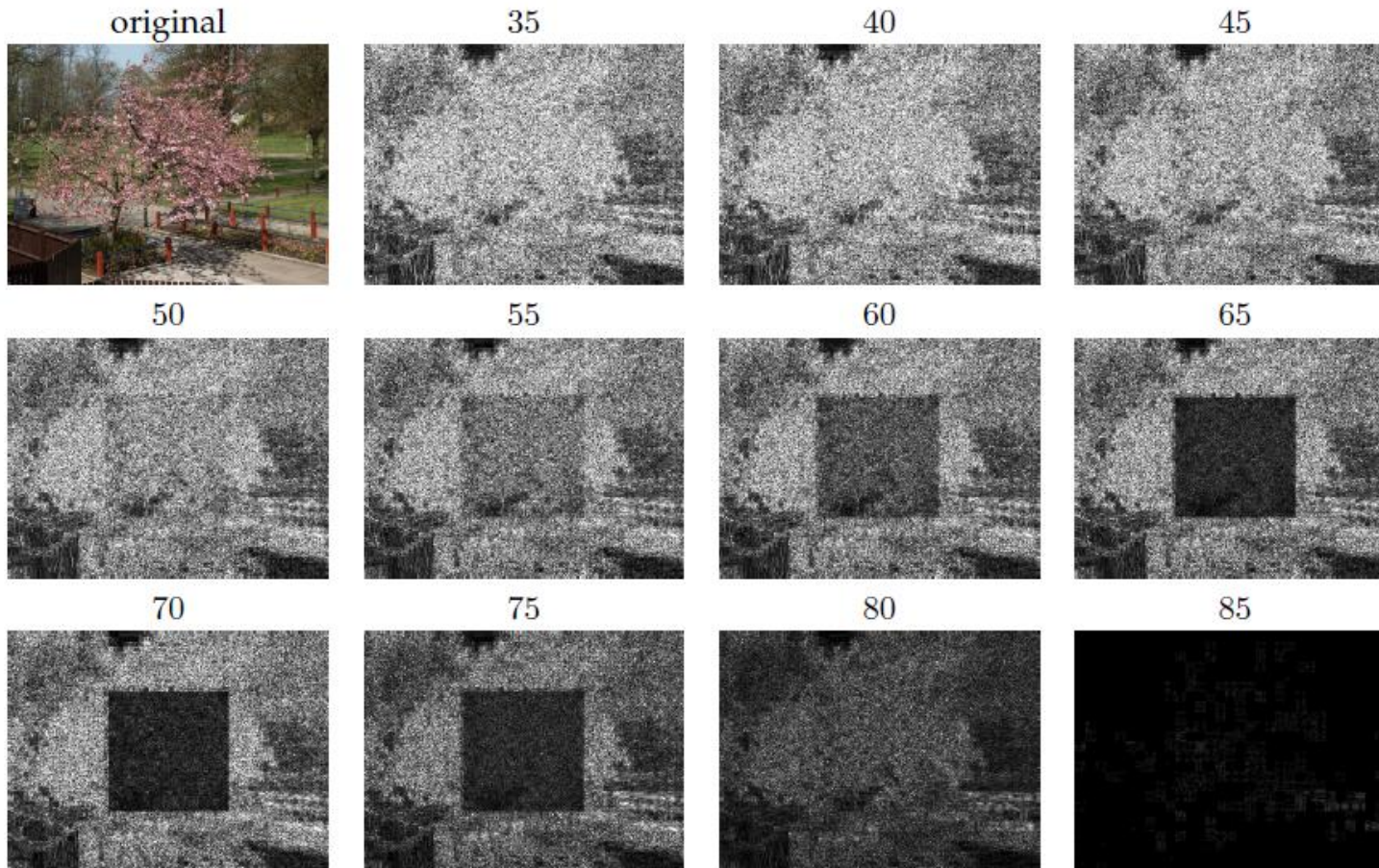

Pixel error for image saved at various JPEG qualities

# JPEG Ghosts

- If there is enough difference between the quality of the pasted region and the final saved quality, the pasted region can be detected with high accuracy

Table 2: JPEG ghost detection accuracy (%)

size	$Q_1 - Q_0$					
	0	5	10	15	20	25
$200 \times 200$	99.2	14.8	52.6	88.1	93.8	99.9
$150 \times 150$	99.2	14.1	48.5	83.9	91.9	99.8
$100 \times 100$	99.1	12.6	44.1	79.5	91.1	99.8
$50 \times 50$	99.3	5.4	27.9	58.8	77.8	97.7



# JPEG Ghosts

original



manipulated

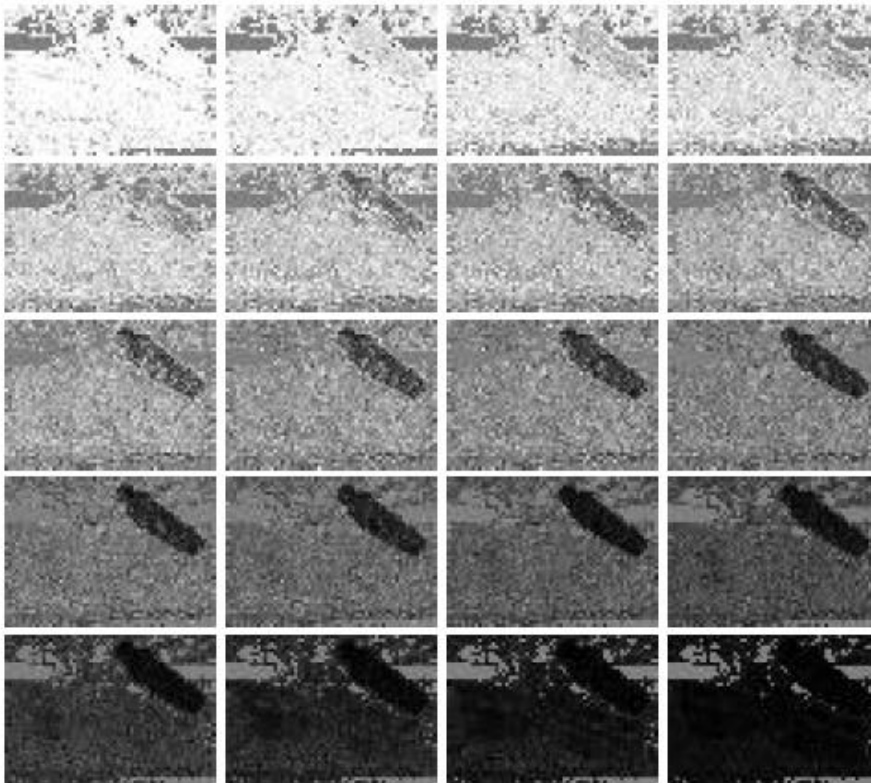

Pixel error for manipulated image saved at various JPEG qualities

# JPEG Ghosts

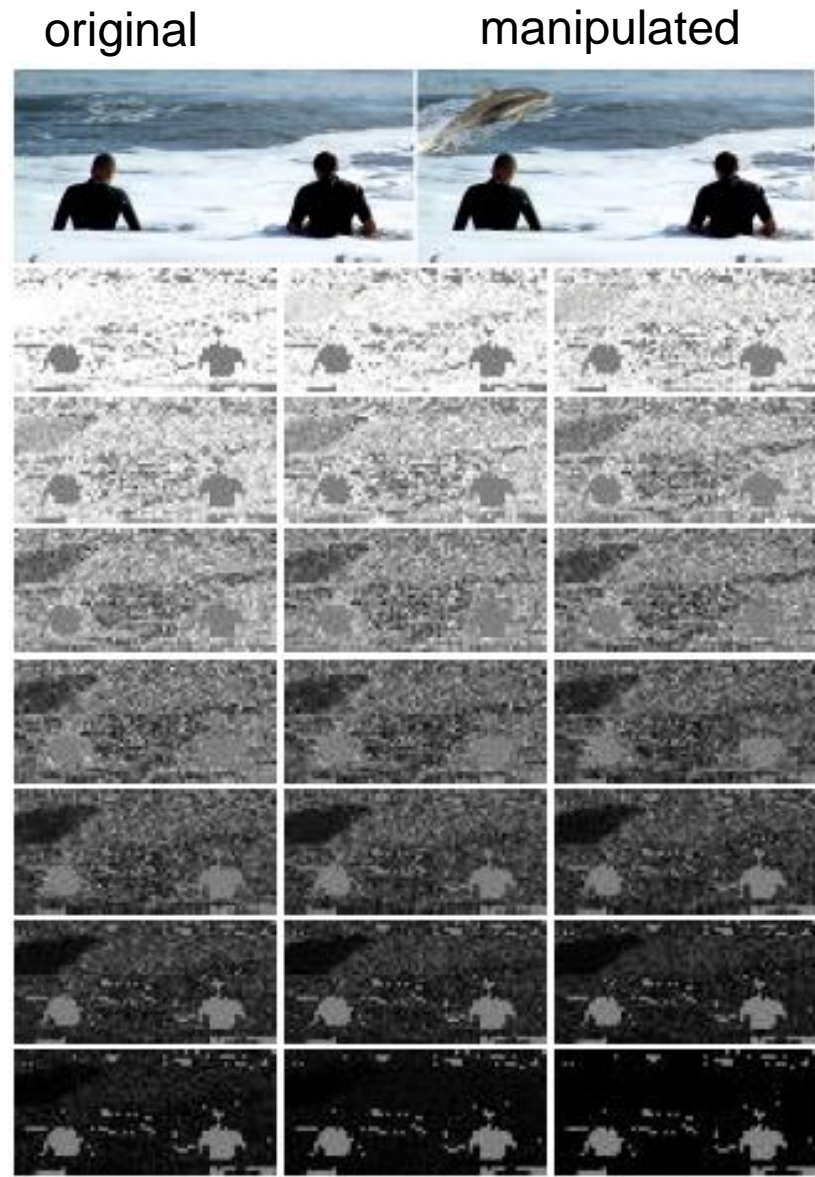

Pixel error for manipulated image saved at various JPEG qualities

# Deep Fakes

[https://journalistsresource.org/studies/society/  
deepfake-technology-5-resources/](https://journalistsresource.org/studies/society/deepfake-technology-5-resources/)



# pix2pix: Image-to-Image Translation

Labels to Street Scene



Labels to Facade

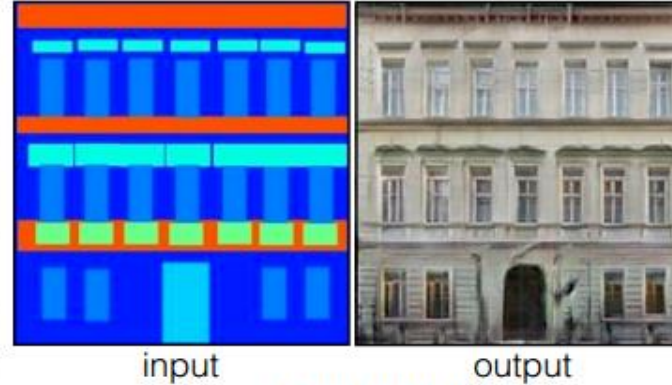

BW to Color



Aerial to Map



Day to Night

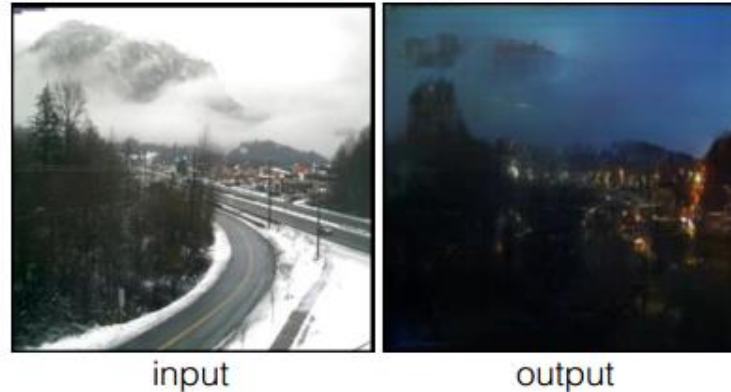

Edges to Photo

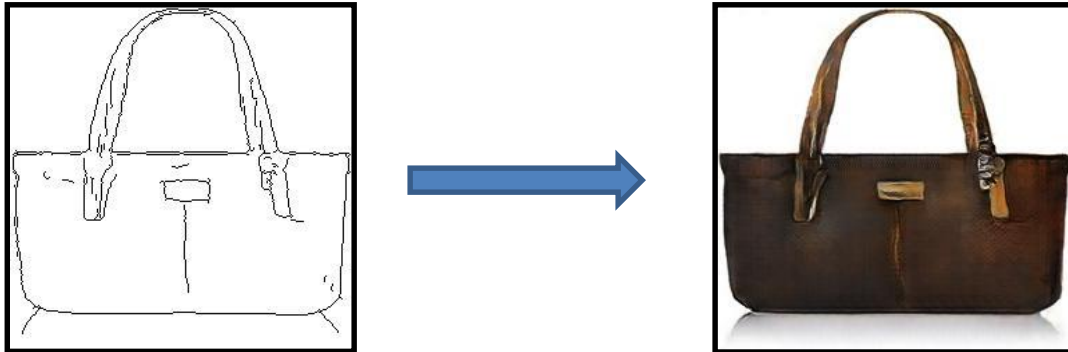

Image-to-image Translation with Conditional Adversarial Nets  
Phillip Isola, Jun-Yan Zhu, Tinghui Zhou, Alexei A. Efros. CVPR 2017



# Image to image translation (pix2pix)

Train a conditional generator to translate from one image domain to another



# Objective 1: L1 Loss

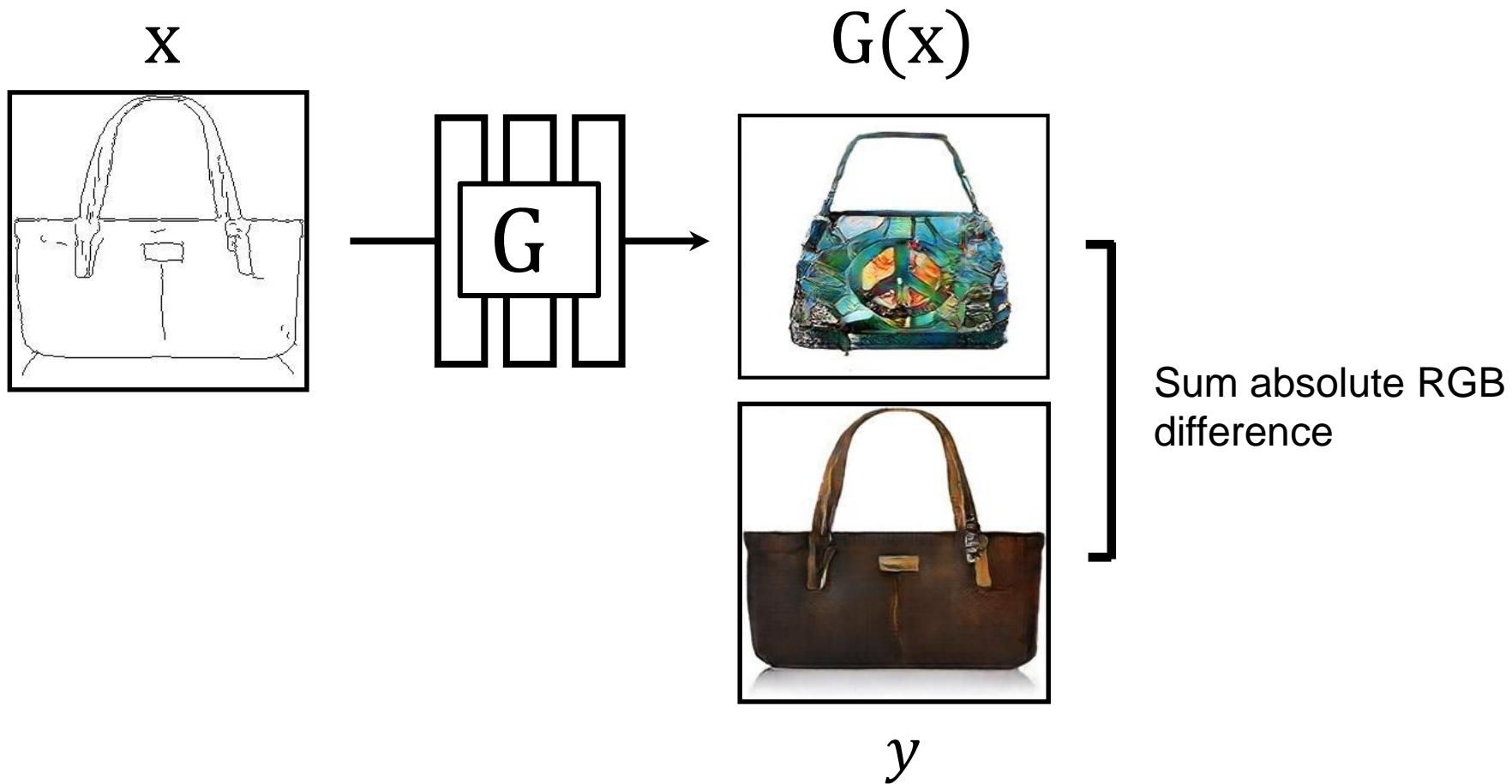

$$L_{L1}(G) = \mathbb{E}_{x,y} \|y - G(x)\|_1$$

# L1 objective tends to produce slightly blurry results

Input

Ground truth

L1



## Objective 2: Paired Adversarial Loss

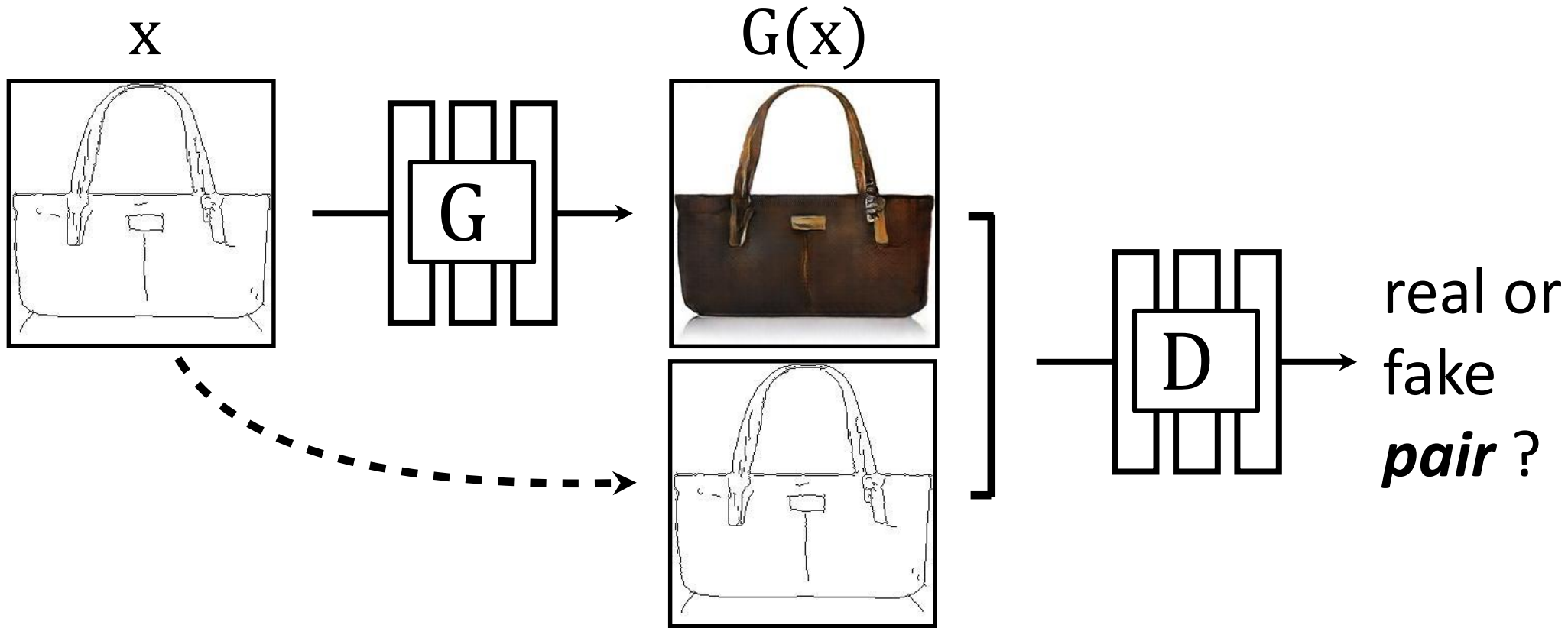

$$L_{GAN}(G, D) = \mathbb{E}_{x,y} [\log \underbrace{D(x, G(x))}_{\text{fake pair}} + \log(\underbrace{1 - D(x, y)}_{\text{real pair}})]$$



# By itself, cGAN has some high texture artifacts

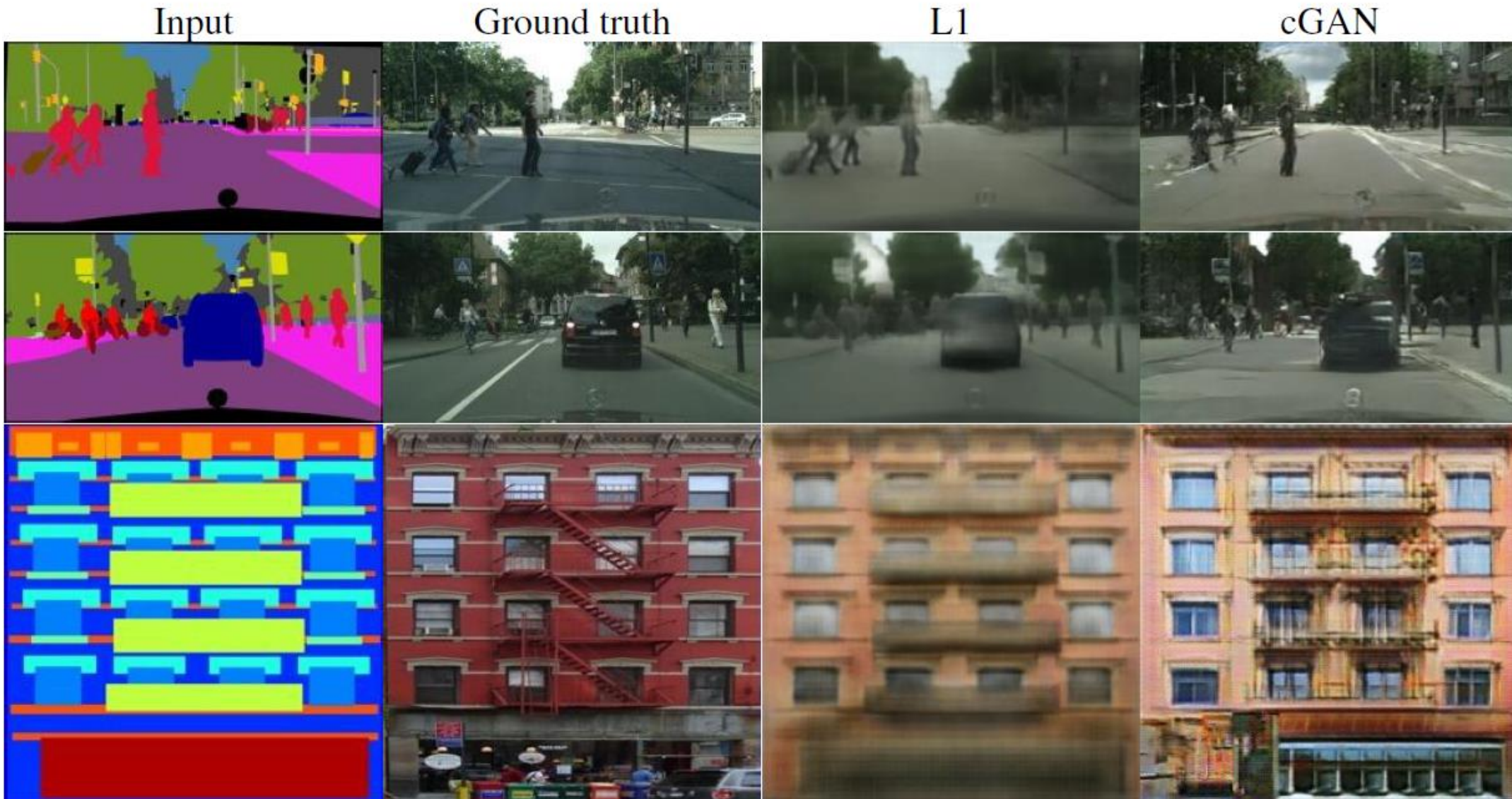

# Combined Objective

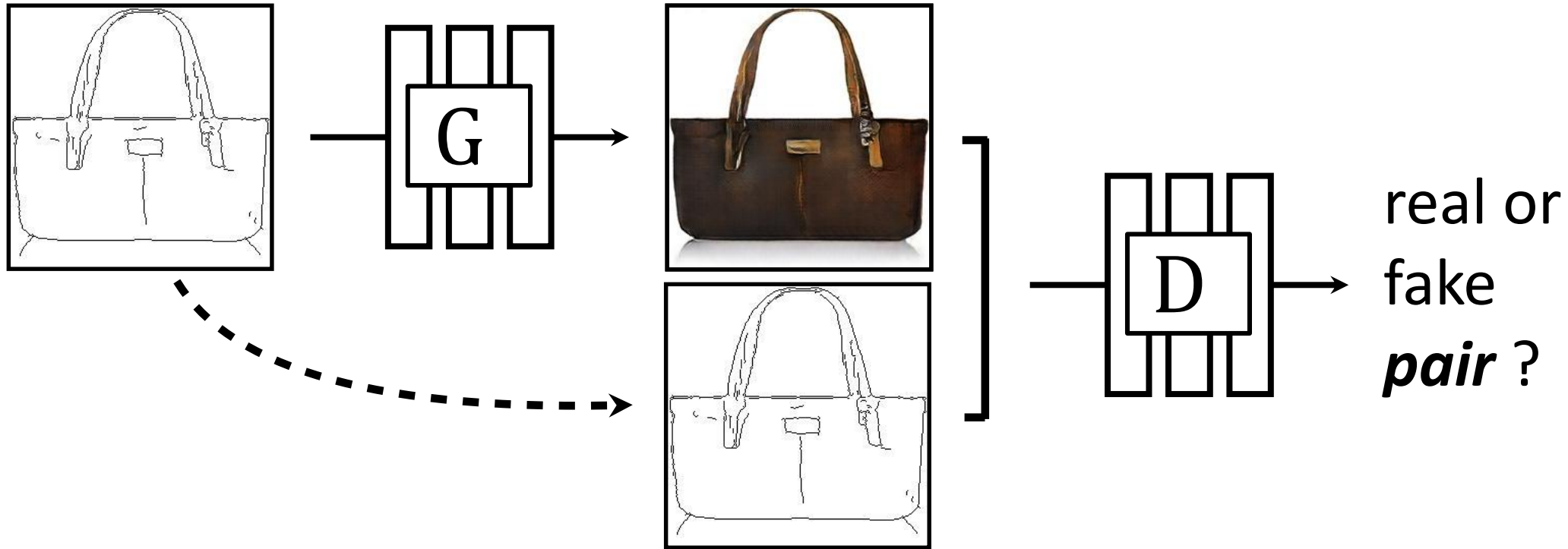

$$G^* = \min_G \max_D L_{GAN}(G, D) + \lambda L_1(G)$$



# Combined objective works best

Input

Ground truth

L1

cGAN

L1 + cGAN



# Design Choices

U-Net Encoder/Decoder helps preserve detail

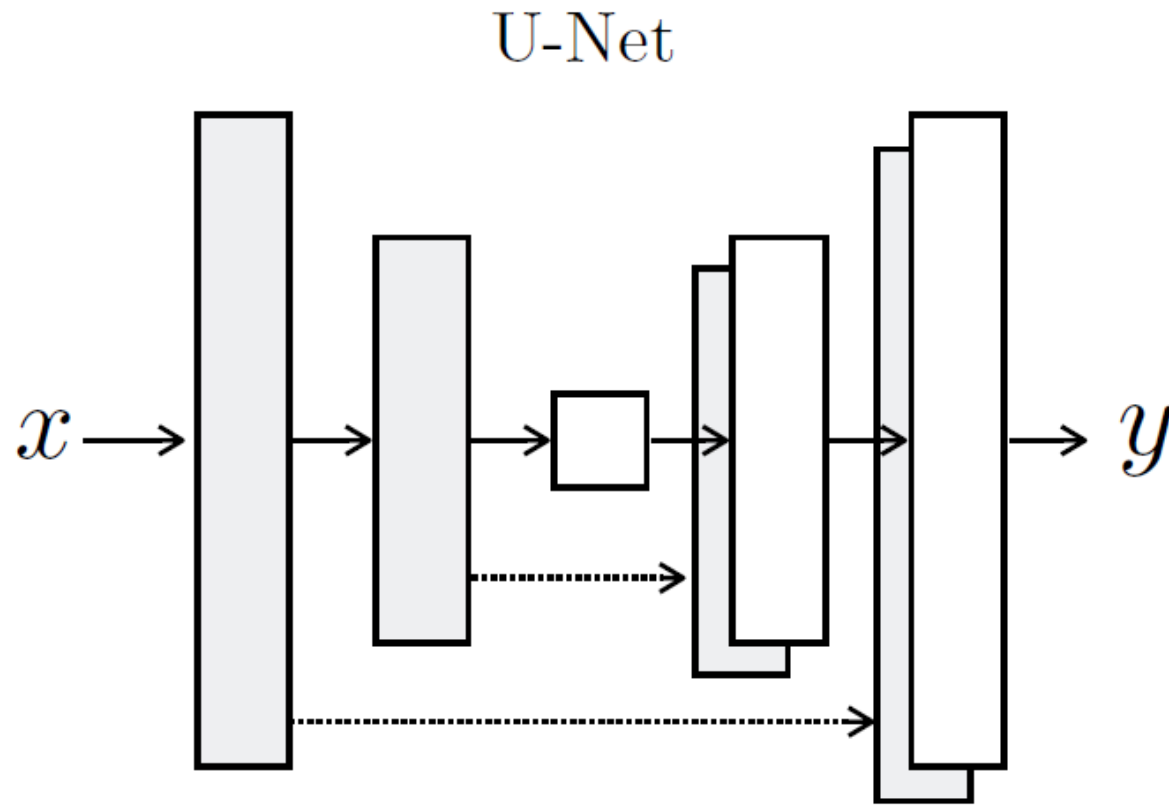



# Design Choices

PatchGAN: Discriminator classifies  $N \times N$  patches so that it focuses on details/texture that L1 loss doesn't capture

- $N \times N = 70 \times 70$  works well in experiments
- Average responses across patches

# Sketches $\rightarrow$ Images

Input

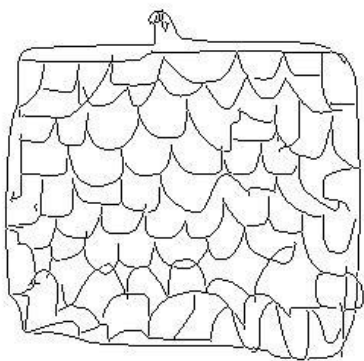

Output



Input

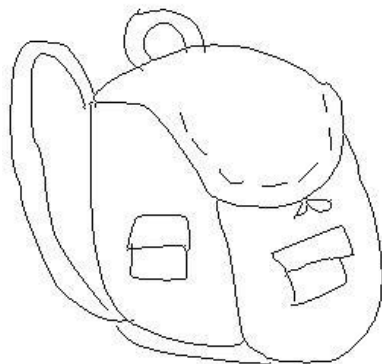

Output



Input

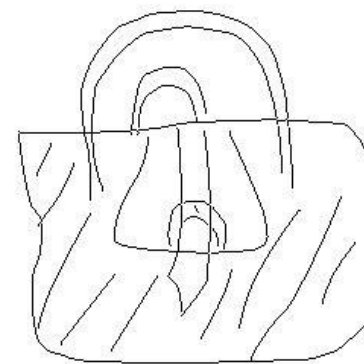

Output

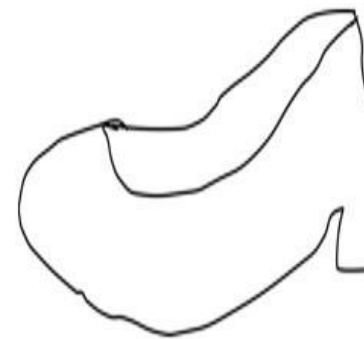
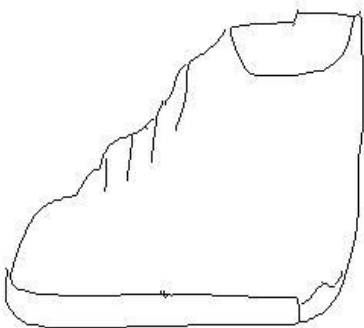

Trained on Edges  $\rightarrow$  Images

# #edges2cats [Christopher Hesse]

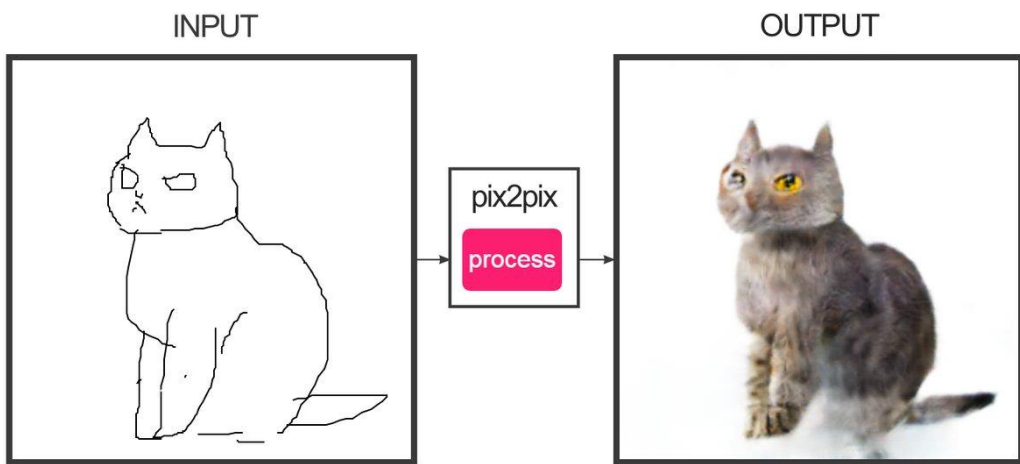

@gods\_tail



Ivy Tasi  
@ivymyt

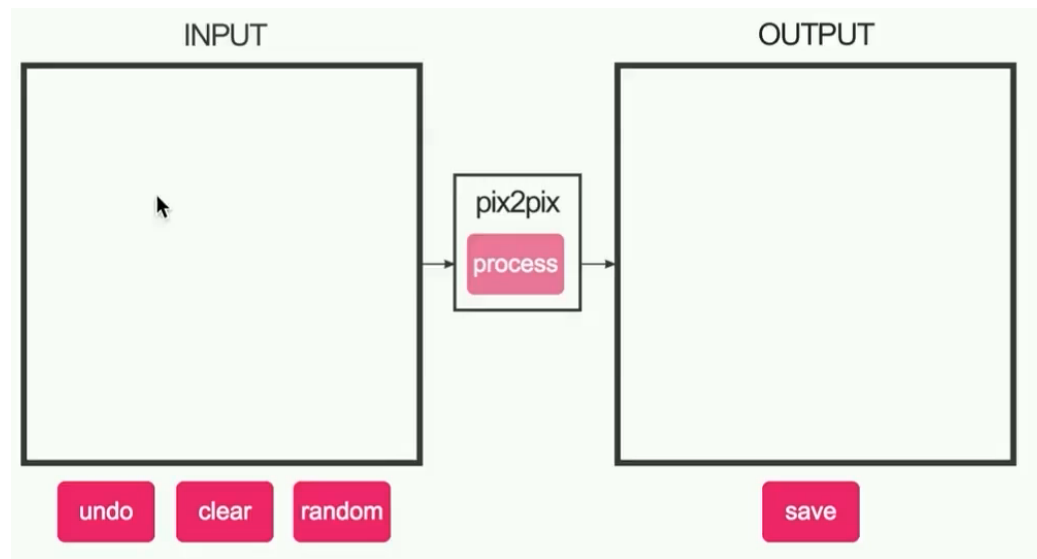

@matthematician



Vitaly Vidmirov @vvid

<https://affinelayer.com/pixsrv/>



Input



Output



Groundtruth



Data from  
[maps.google.com]





# BW → Color

Input

Output

Input

Output

Input

Output





# Unpaired Image-to-Image Translation using Cycle-Consistent Adversarial Networks

ICCV 2017

Jun-Yan Zhu\*

Taesung Park\*

Phillip Isola

Alexei A. Efros

Berkeley AI Research (BAIR) laboratory, UC Berkeley

Monet ↔ Photos



Monet → photo

Zebras ↔ Horses



zebra → horse

Summer ↔ Winter



summer → winter

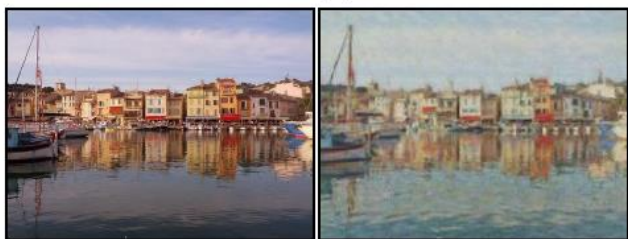

photo → Monet



horse → zebra



winter → summer



Photograph



Monet



Van Gogh



Cezanne



Ukiyo-e

# Cycle GAN

- Hard to get exact image domain translations for training, but easy to get unmatched sets of images
- Key idea: if you translate an image and then translate it back, you should get the original

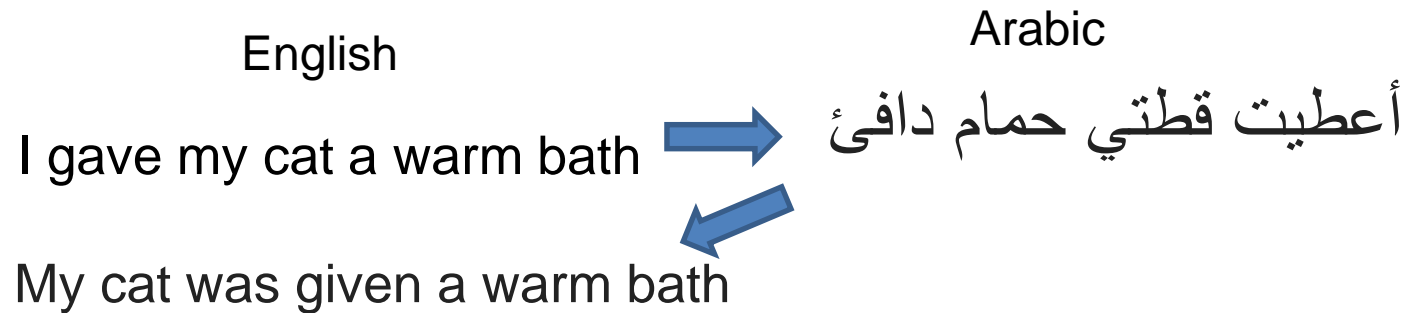

# Cycle Consistency Loss

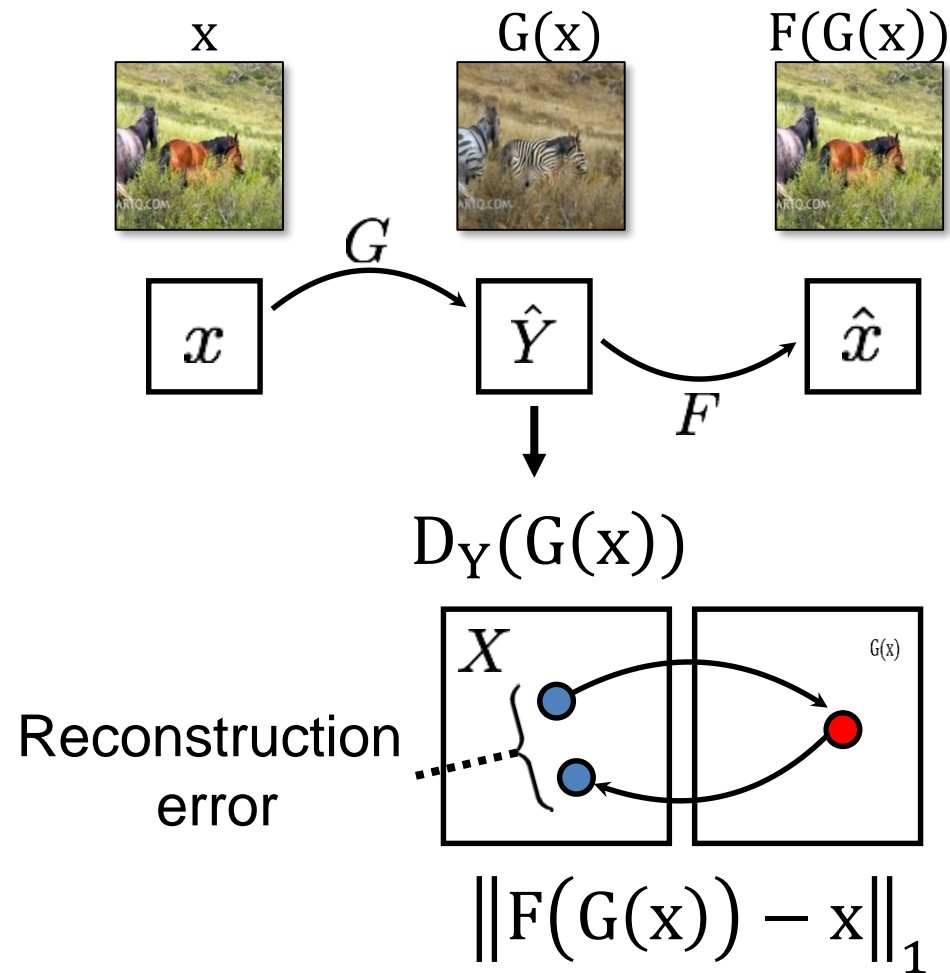



# Cycle Consistency Loss

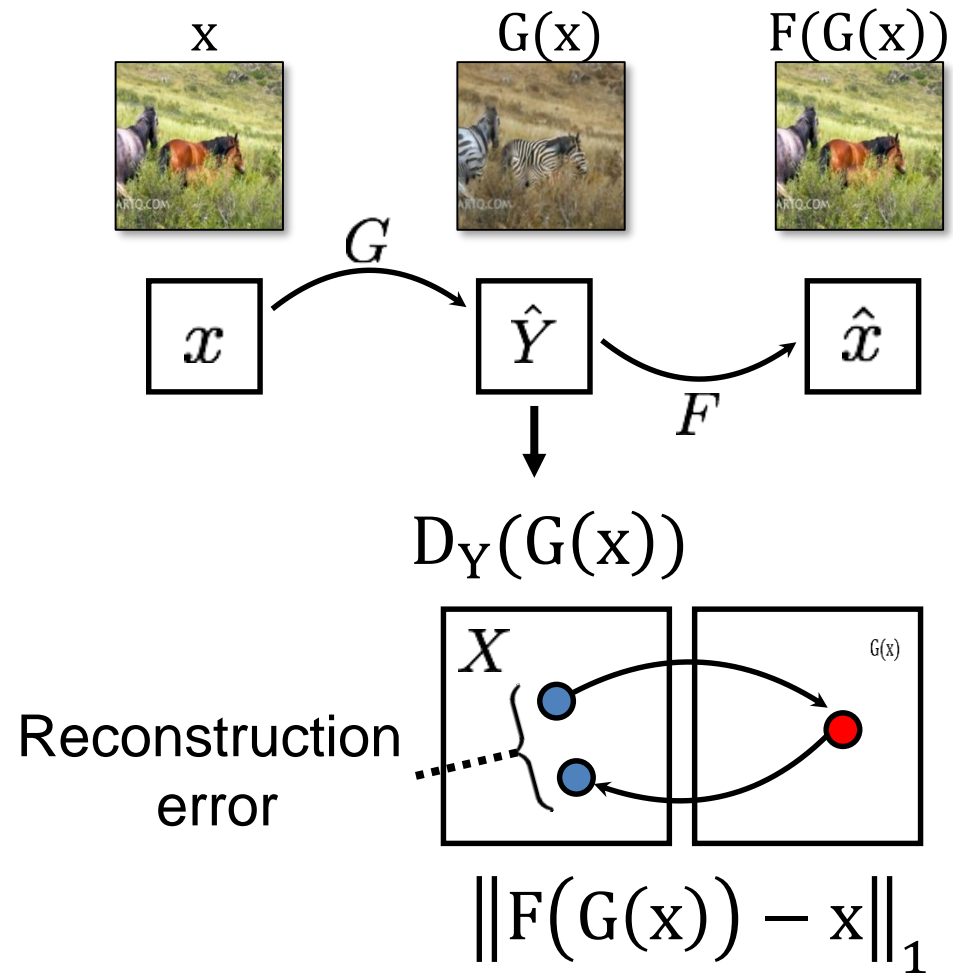

Single cycle loss

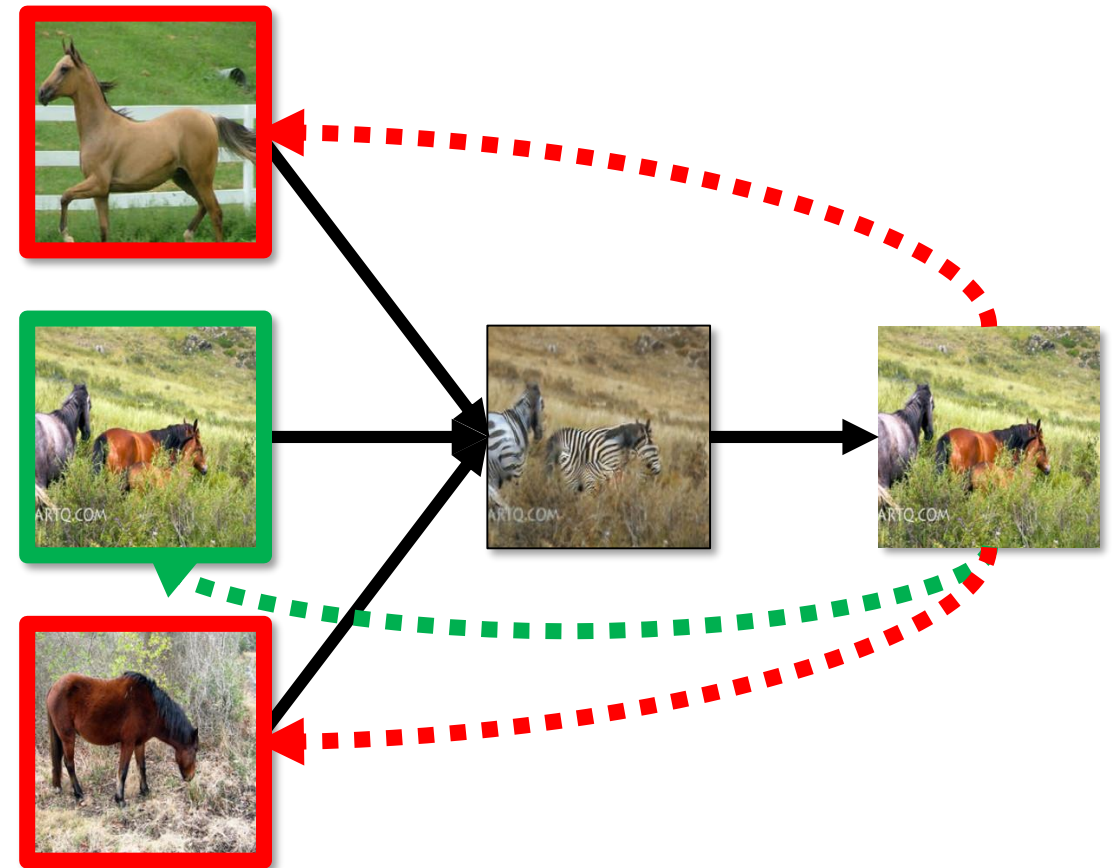

# Cycle Consistency Loss

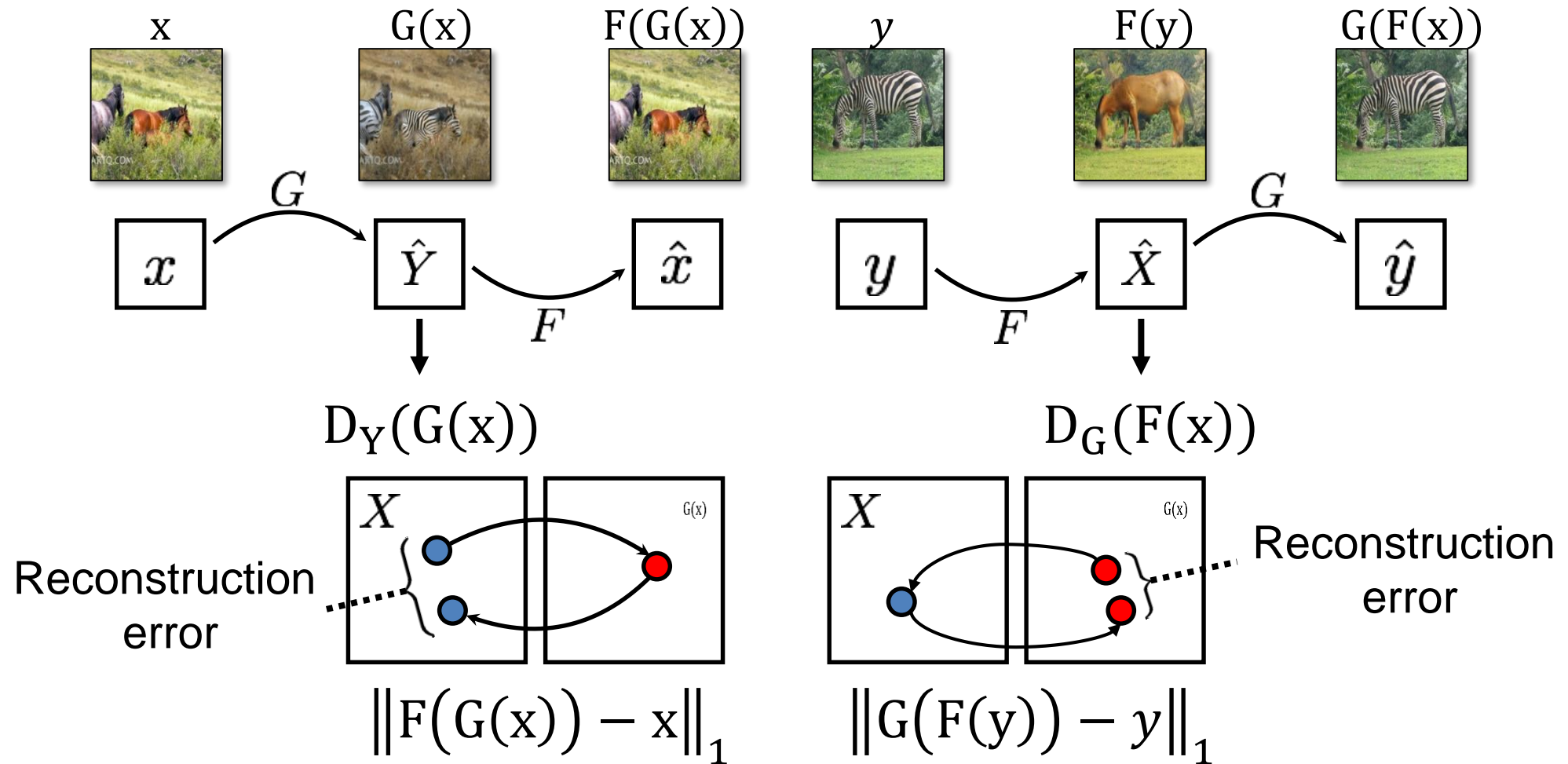

# Cycle GAN: Full Objective

Produce images that look like each domain (according to discriminators) and complete a cycle

For  $\mathcal{L}_{GAN}$  a squared loss is used instead of log loss

$$\begin{aligned}\mathcal{L}(G, F, D_X, D_Y) = & \mathcal{L}_{GAN}(G, D_Y, X, Y) \\ & + \mathcal{L}_{GAN}(F, D_X, Y, X) \\ & + \lambda \mathcal{L}_{cyc}(G, F),\end{aligned}$$

# Collection Style Transfer



Photograph  
@ Alexei Efros



Ukiyo-e Cezanne

Van Gogh Monet



Input



Monet



Van Gogh



Cezanne



Ukiyo-e

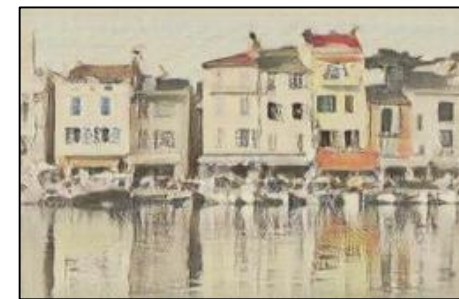
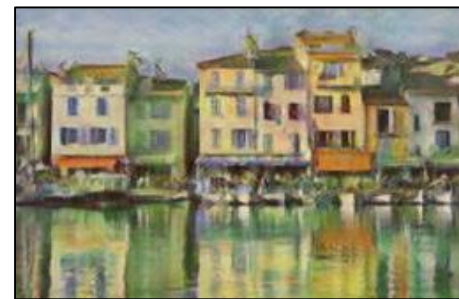
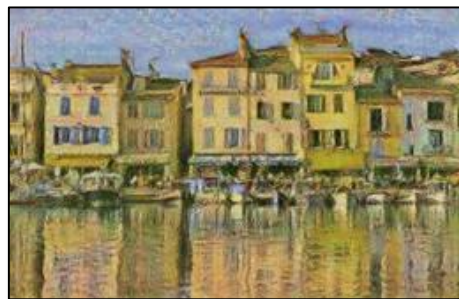



# Monet's paintings → photos





# Monet's paintings → photos













# CycleGAN Horse -> Zebra

<https://youtu.be/9reHvktowLY>



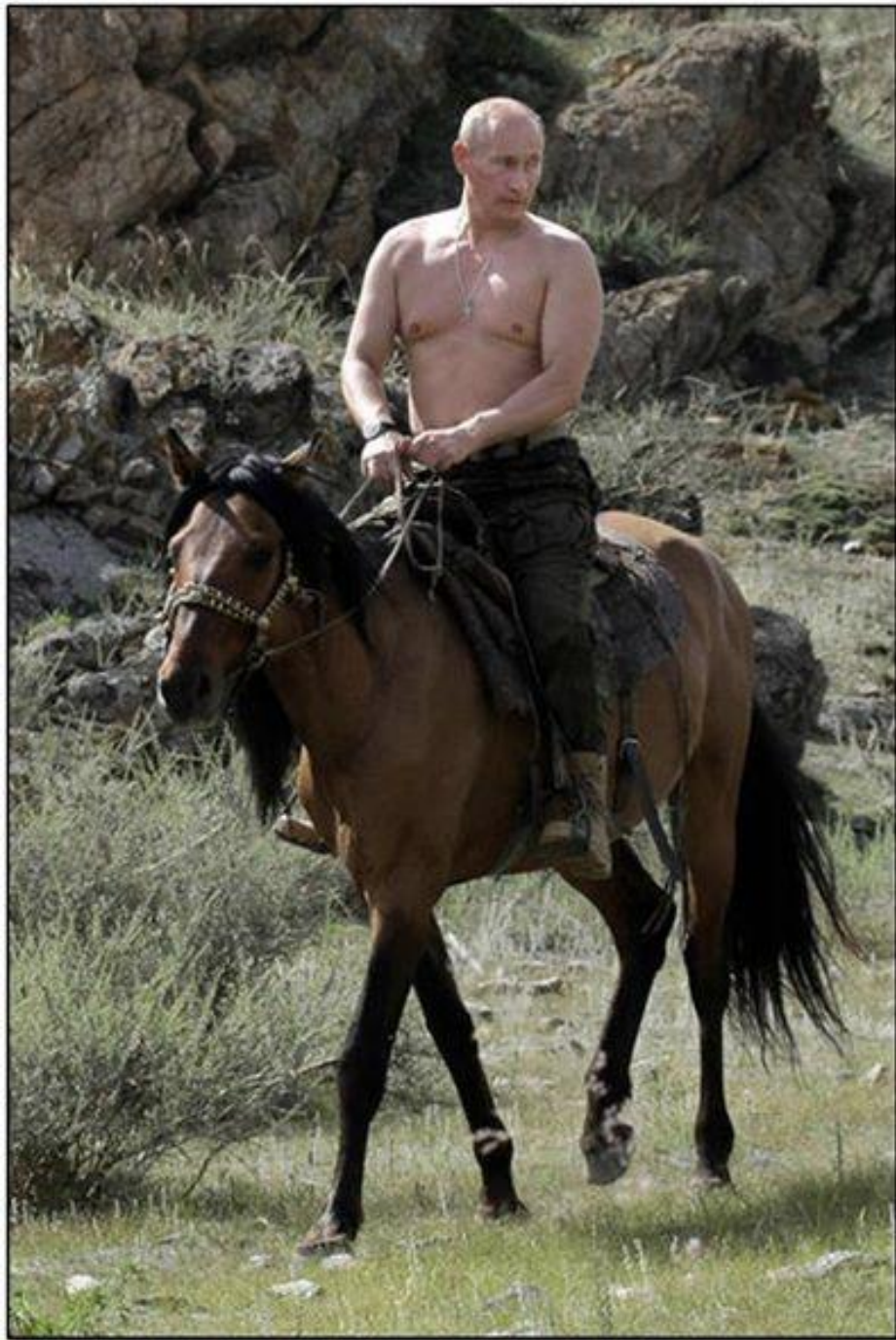



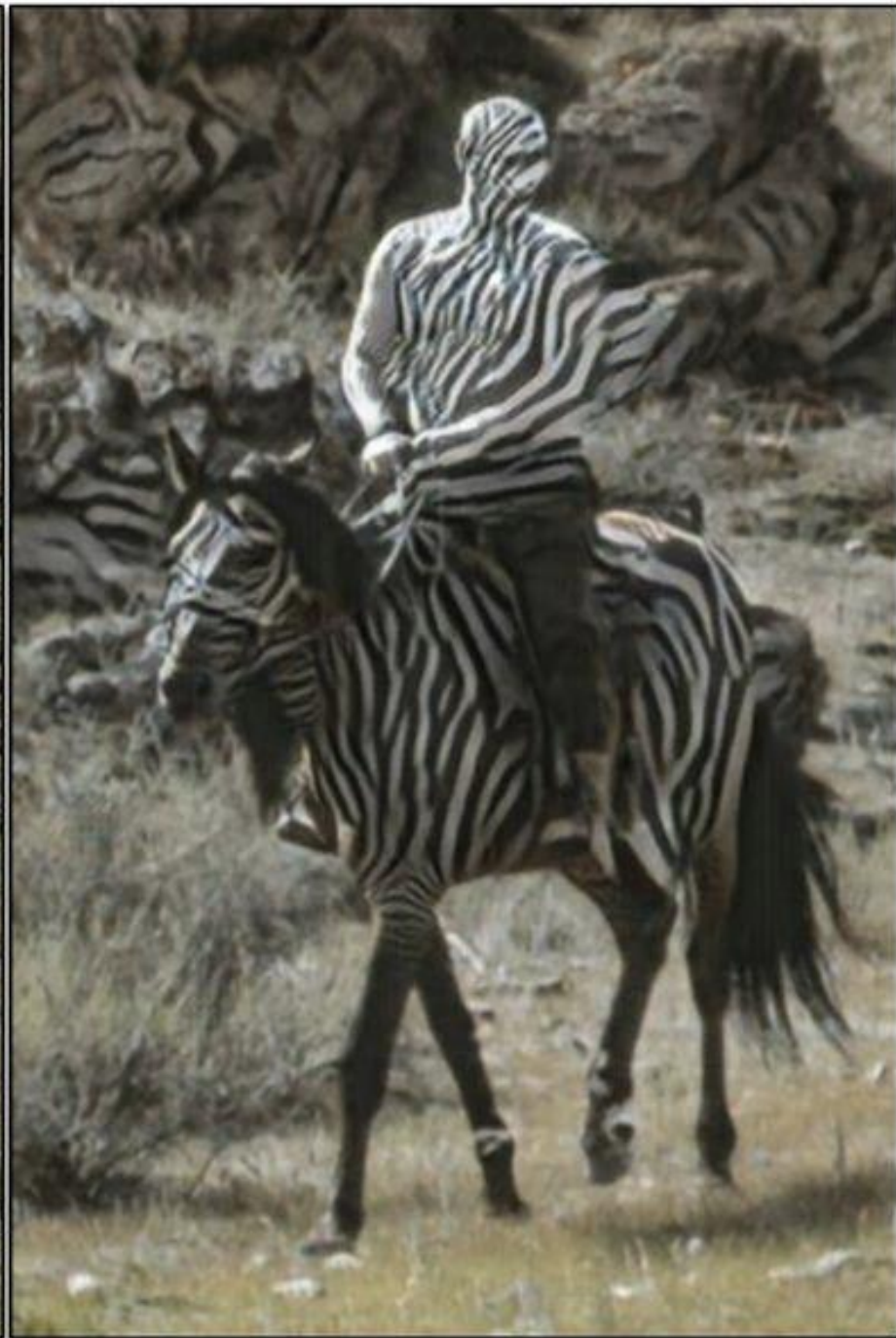
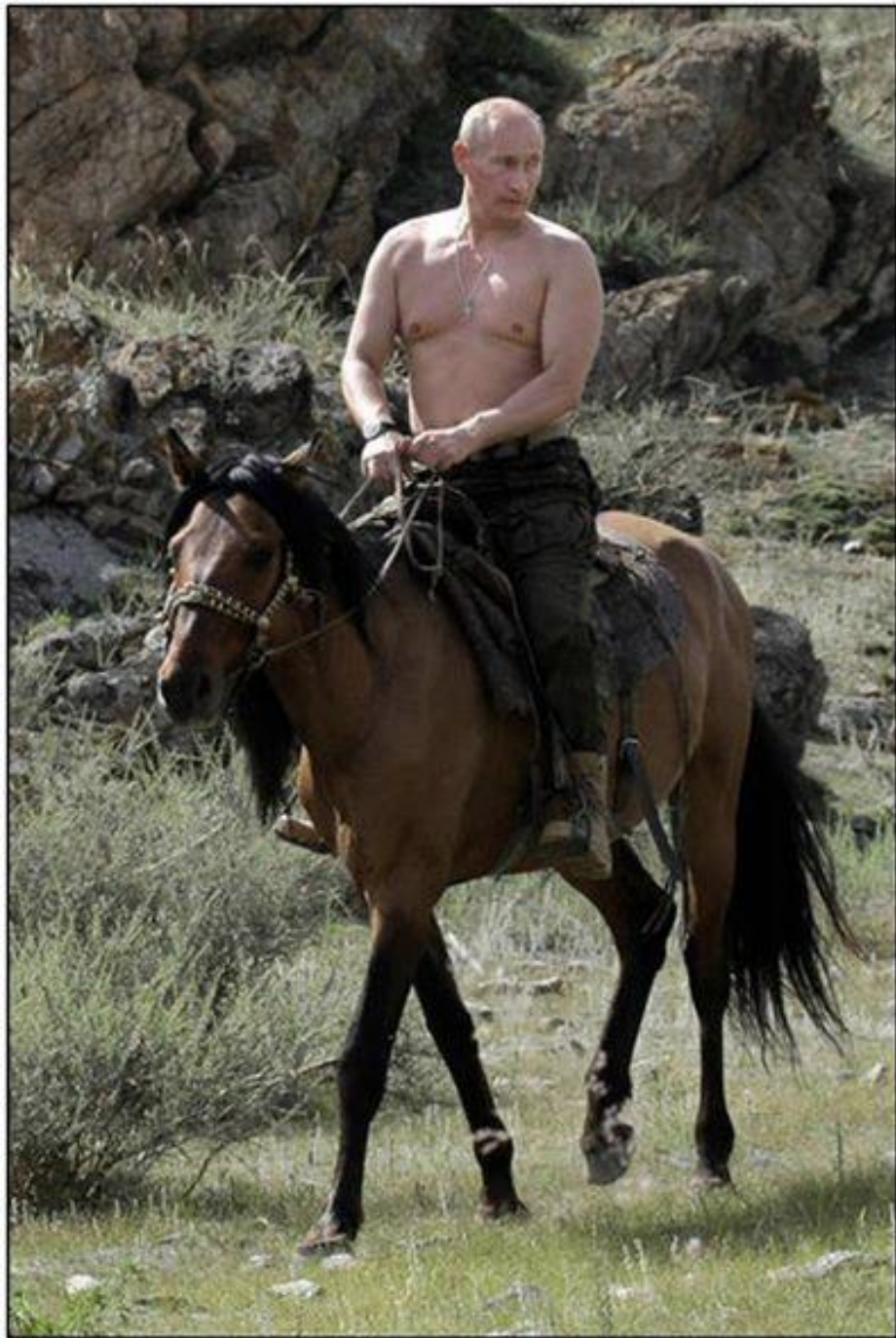

# Everybody Dance Now

ICCV 2019

Caroline Chan\*

Shiry Ginosar

Tinghui Zhou†

Alexei A. Efros

UC Berkeley

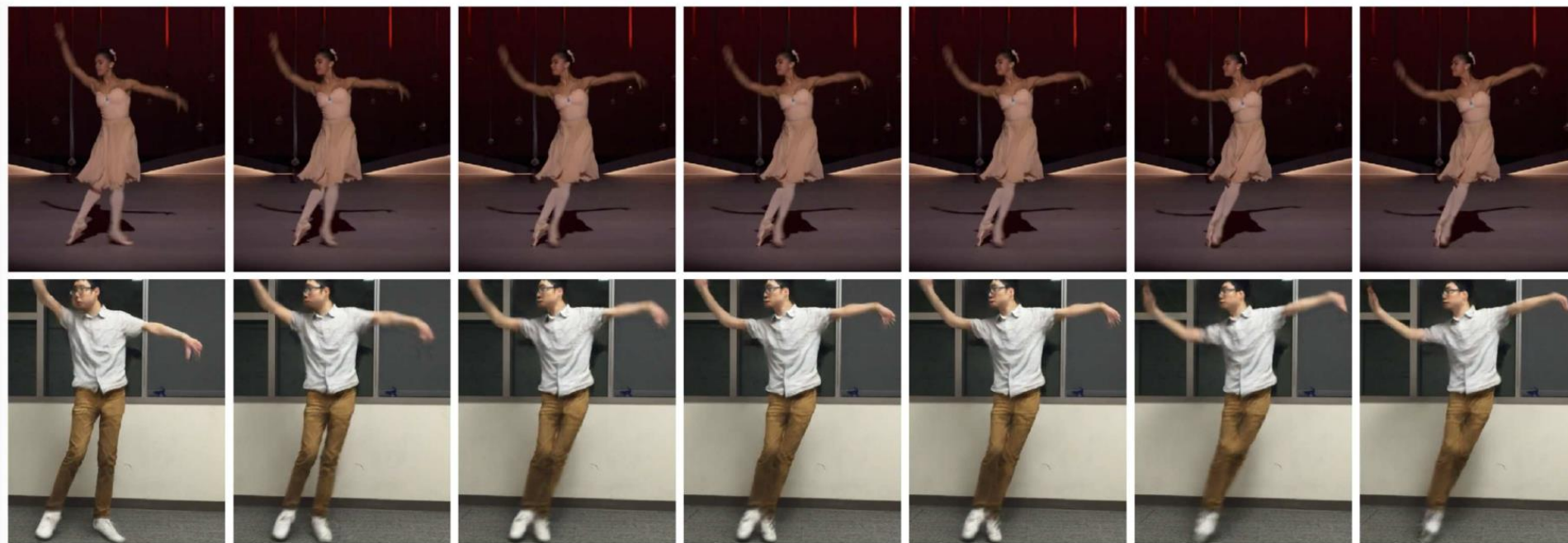

Figure 1: “Do as I Do” motion transfer: given a YouTube clip of a ballerina (top), and a video of a graduate student performing various motions, our method transfers the ballerina’s performance onto the student (bottom). Video: <https://youtu.be/mSaIrz8lM1U>



# Everybody Dance Now



Video to Pose  
→  
Open Pose  
  
Pose to Video  
←  
Conditional GAN

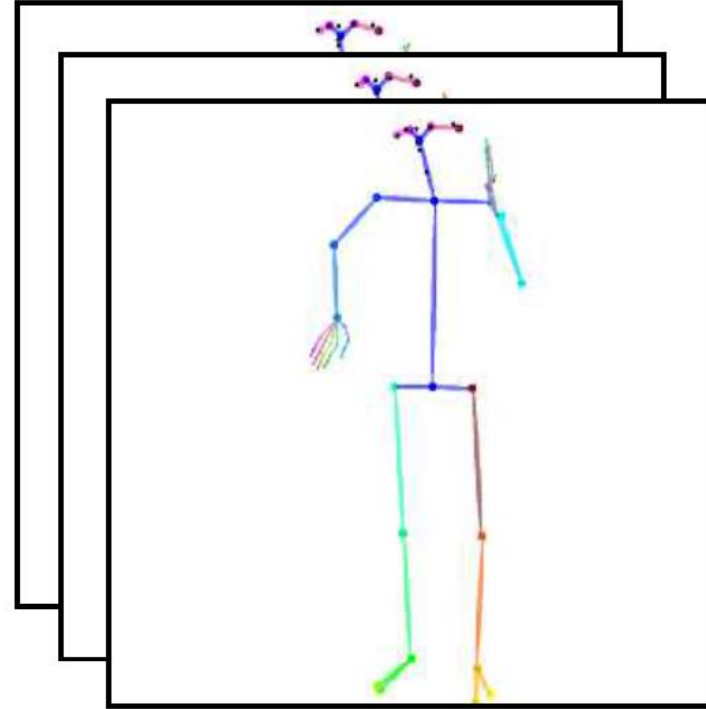



# Everybody Dance Now

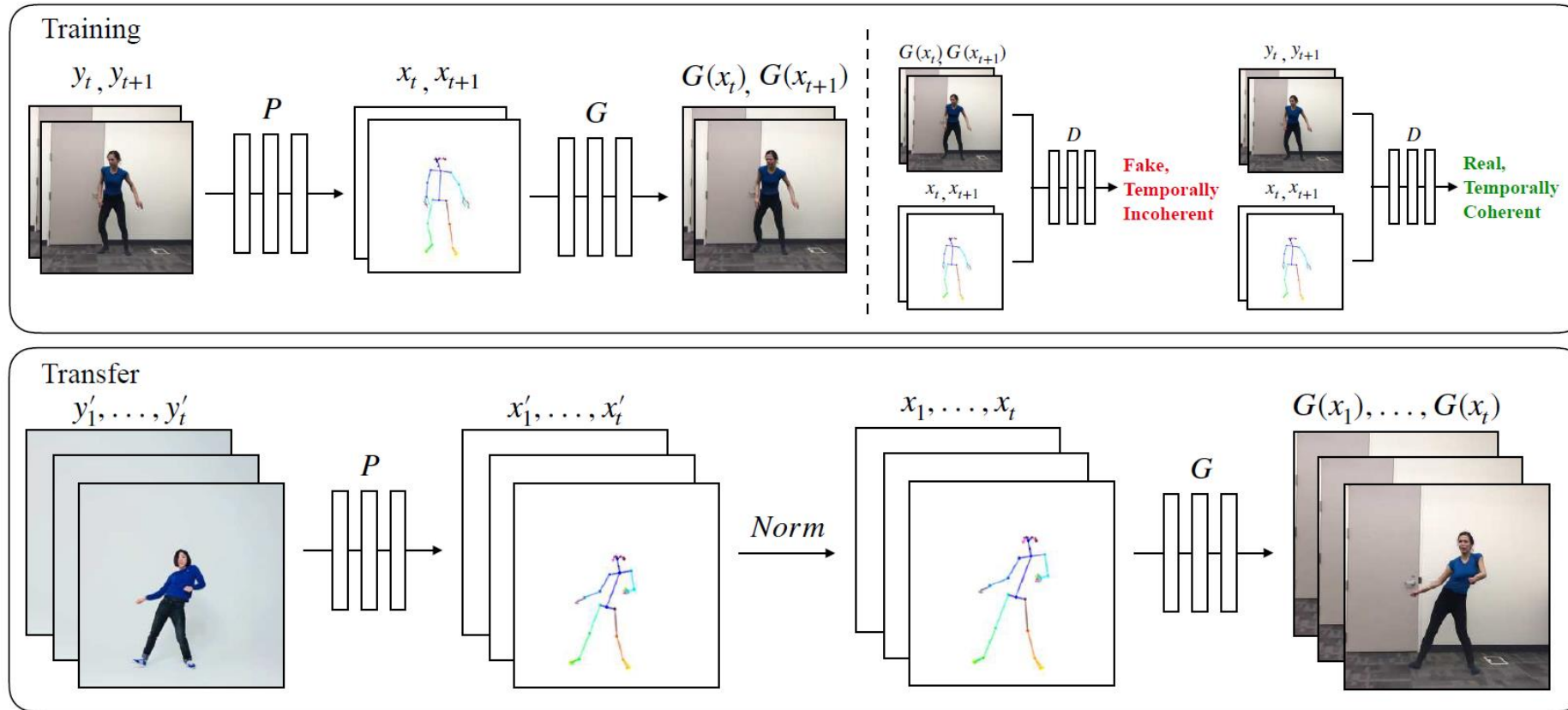

- Optimize a body GAN, face GAN, and temporal smoothness
- Discriminator conditions on pose and previous image and uses a perceptual distance for loss

# Everybody Dance Now Video

<https://www.youtube.com/watch?v=PCBTZh41Ris>

# How to detect deep fakes?

- “Everybody dance now” provides a classifier to identify videos produced by their system
- Google is creating DeepFake data for researchers:  
<https://ai.googleblog.com/2019/09/contributing-data-to-deepfake-detection.html>
- Deep fake detection article:  
<https://nerdist.com/article/deepfake-detector/>  
<https://youtu.be/RoGHVI-w9bE>



# Summary

- Digital forgeries are an increasingly major problem as it becomes easier to fake images
- A variety of automatic and semi-automatic methods are available for detection of well-done forgeries
  - Checking lighting consistency
  - Checking demosaicking consistency (for high quality images)
  - Checking JPEG compression level consistency (for low quality images)
- “Deep fakes” have recently become effective, and deep fake detection is a hot research topic

# Upcoming

- Next: How the Kinect Works
- After that: Computational Cameras