

Chapter 2: Memory Hierarchy Design (Part 3)

Introduction

Caches

Main Memory (Section 2.2)

Virtual Memory (Section 2.4, Appendix B.4, B.5)

Memory Technologies

Dynamic Random Access Memory (DRAM)

- Optimized for density, not speed

 - One transistor cells

- Multiplexed address pins

 - Row Address Strobe (RAS)

 - Column Address Strobe (CAS)

- Cycle time > access time

 - Destructive reads

- Must refresh every few ms

 - Access every row

- Sold as dual inline memory modules (DIMMs)

Memory Technologies, cont.

Static Random Access Memory (SRAM)

Optimized for speed, then density

Typically 6 transistors per cell

Separate address pins

Static \Rightarrow No Refresh

Greater power dissipation than DRAM

Access time = cycle time

DRAM Organization

DIMM

Rank

Bank

Array

Row buffer

See figure 1.5 in

The Memory System: You Can't Avoid It, You Can't Ignore It, You Can't Fake It

By Bruce Jacob

Synthesis Lectures on Computer Architecture, Morgan & Claypool

Series editor: Mark Hill

Downloadable from U of I network

<https://www.morganclaypool.com/doi/pdfplus/10.2200/S00201ED1V01Y200907CAC007>

DRAM Organization

Rank: chips needed to respond to a single request

Assume 64 bit data bus

For 8 bit DRAM, need 8 chips in a rank

For 4 bit DRAM, need 16 chips in a rank

Can have multiple ranks per DIMM

Bank: A chip is divided into multiple independent banks for **pipelined** access

Array: A bank consists of many arrays, 1 array per bit of output, for **parallel** access

Row buffer: A “**cache**” that preserves the last row read from a bank

Internals of a DRAM Array

See Figure 1.6 of the synthesis lecture

Steps to access a bit

Pre-charge bit lines

Activate row: turn on word line for the row, brings data to sense
amps

Column read: send subset of data (columns)

(Restore data)

DRAM Optimizations – Page Mode

Unoptimized DRAM

First read entire row

Then select column from row

Stores entire row in a buffer

Page Mode

Row buffer acts like an SRAM

By changing column address, random bits can be accessed
within a row.

DRAM Optimizations – Synchronous DRAM

Previously, DRAM had asynchronous interface

Each transfer involves handshaking with controller

Synchronous DRAM (SDRAM)

- Clock added to interface

- Register to hold number of bytes requested

- Send multiple bytes per request

Double Data Rate (DDR)

- Send data on rising and falling edge of clock

Simple Main Memory

Consider a memory with these parameters:

1 cycle to send address

6 cycles to access each word

1 cycle to send word back to CPU/Cache

What's the miss penalty for a 4word block?

$$(1 + 6 \text{ cycles} + 1 \text{ cycle}) \times 4 \text{ words} \\ = 32 \text{ cycles}$$

How can we speed this up?

Wider Main Memory

Make the memory wider

Read out 2 (or more) words in parallel

Memory parameters:

1 cycle to send address

6 cycles to access each *doubleword*

1 cycle to send doubleword back to CPU/Cache

Miss penalty for a 4 word block:

$$(1 + 6 \text{ cycles} + 1 \text{ cycle}) \times 2 \text{ doublewords} \\ = 16 \text{ cycles}$$

Interleaved Main Memory

Organize memory in banks

Subsequent words map to different banks

Word A in bank $(A \bmod M)$

Within a bank, word A in location $(A \text{ div } M)$

Word address

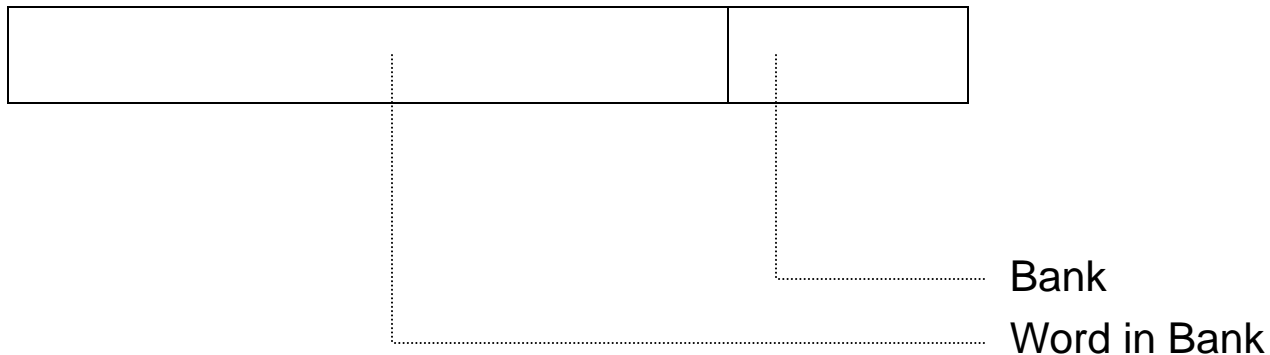

How many banks to include?

*Interleaved Main Memory***

Organize memory in banks

Subsequent words map to different banks

Word A in bank $(A \bmod M)$

Within a bank, word A in location $(A \text{ div } M)$

Word address

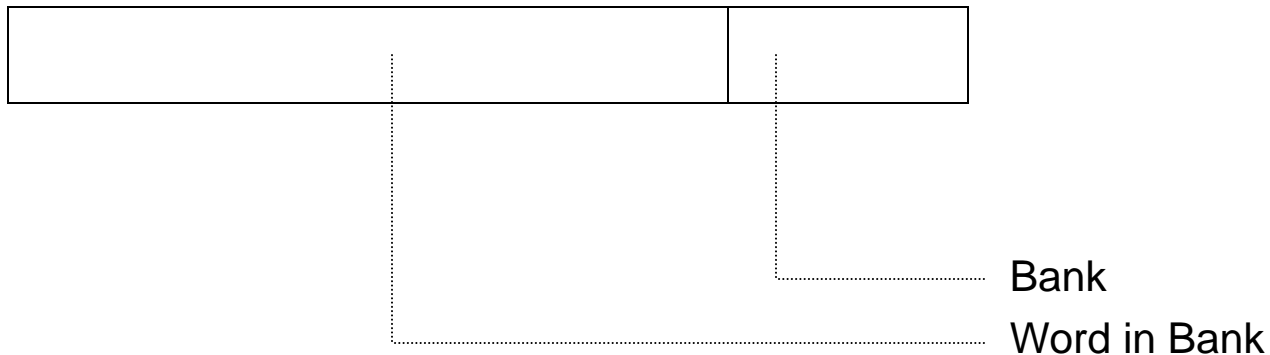

How many banks to include?

banks \geq # clock cycles to access word in a bank

Production year	Chip size	DRAM type	Best case access time (no precharge)			Precharge needed
			RAS time (ns)	CAS time (ns)	Total (ns)	Total (ns)
2000	256M bit	DDR1	21	21	42	63
2002	512M bit	DDR1	15	15	30	45
2004	1G bit	DDR2	15	15	30	45
2006	2G bit	DDR2	10	10	20	30
2010	4G bit	DDR3	13	13	26	39
2016	8G bit	DDR4	13	13	26	39

Figure 2.4 Capacity and access times for DDR SDRAMs by year of production. Access time is for a random memory word and assumes a new row must be opened. If the row is in a different bank, we assume the bank is precharged; if the row is not open, then a precharge is required, and the access time is longer. As the number of banks has increased, the ability to hide the precharge time has also increased. DDR4 SDRAMs were initially expected in 2014, but did not begin production until early 2016.

Standard	I/O clock rate	M transfers/s	DRAM name	MiB/s/DIMM	DIMM name
DDR1	133	266	DDR266	2128	PC2100
DDR1	150	300	DDR300	2400	PC2400
DDR1	200	400	DDR400	3200	PC3200
DDR2	266	533	DDR2-533	4264	PC4300
DDR2	333	667	DDR2-667	5336	PC5300
DDR2	400	800	DDR2-800	6400	PC6400
DDR3	533	1066	DDR3-1066	8528	PC8500
DDR3	666	1333	DDR3-1333	10,664	PC10700
DDR3	800	1600	DDR3-1600	12,800	PC12800
DDR4	1333	2666	DDR4-2666	21,300	PC21300

Figure 2.5 Clock rates, bandwidth, and names of DDR DRAMS and DIMMs in 2016. Note the numerical relationship between the columns. The third column is twice the second, and the fourth uses the number from the third column in the name of the DRAM chip. The fifth column is eight times the third column, and a rounded version of this number is used in the name of the DIMM. DDR4 saw significant first use in 2016.

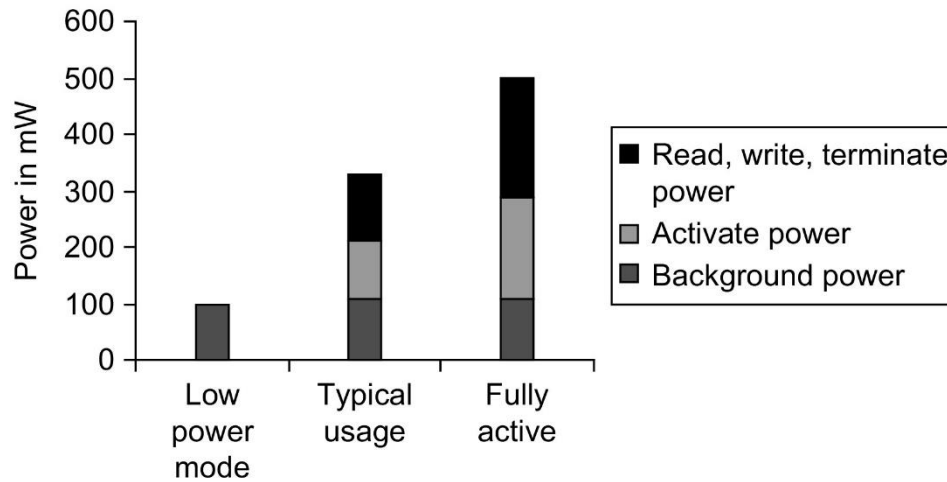

Figure 2.6 Power consumption for a DDR3 SDRAM operating under three conditions: low-power (shutdown) mode, typical system mode (DRAM is active 30% of the time for reads and 15% for writes), and fully active mode, where the DRAM is continuously reading or writing. Reads and writes assume bursts of eight transfers. These data are based on a Micron 1.5V 2GB DDR3-1066, although similar savings occur in DDR4 SDRAMs.

Other Technologies

Graphics Data RAMS (GDDR)

Wider (32 bits), higher clock, connect directly to GPUs (soldered to board vs. DIMMs)

Die stacked DRAMs / 3D / High Bandwidth Memory (HBM)

Nonvolatile memory (later)

Flash

Phase change

Reliability: Parity, ECC, chipkill

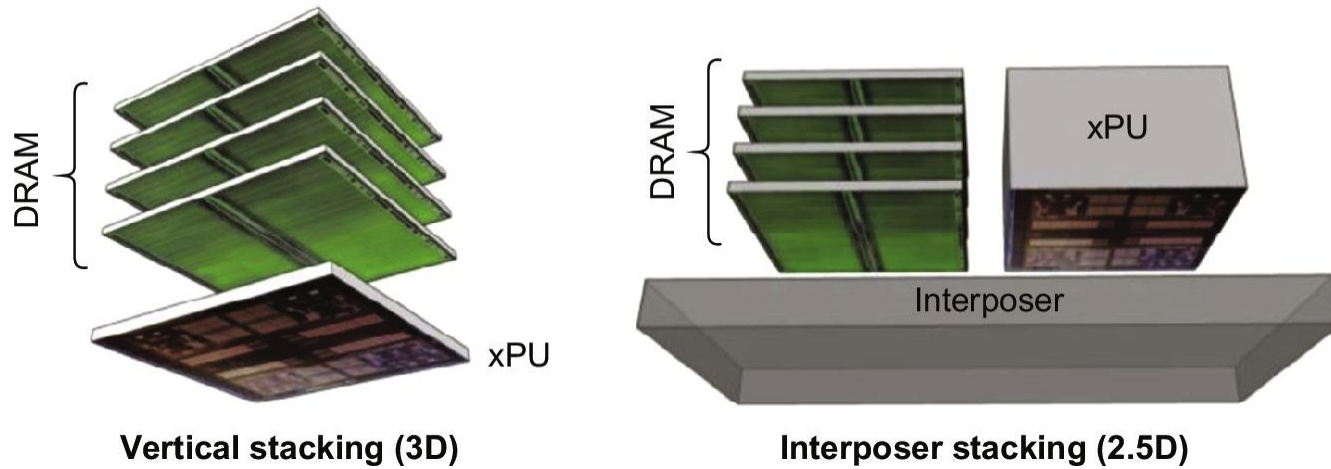

Figure 2.7 Two forms of die stacking. The 2.5D form is available now. 3D stacking is under development and faces heat management challenges due to the CPU.

Virtual Memory

User operates in a virtual address space, mapping between virtual space and main memory is determined at runtime

Original Motivation

- Avoid overlays

- Use main memory as a cache for disk

Current motivation

- Relocation

- Protection

- Sharing

- Fast startup

Engineered differently than CPU caches

- Miss access time $O(1,000,000)$

- Miss access time \gg miss transfer time

Virtual Memory, cont.

Blocks, called *pages*, are 512 to 16K bytes.

Page placement

Fully-associative -- avoid expensive misses

Page identification

Address translation -- virtual to physical address

Indirection through one or two page tables

Translation cached in translation buffer

Page replacement

Approx. LRU

Write strategy

Writeback (with page dirty bit)

Address Translation

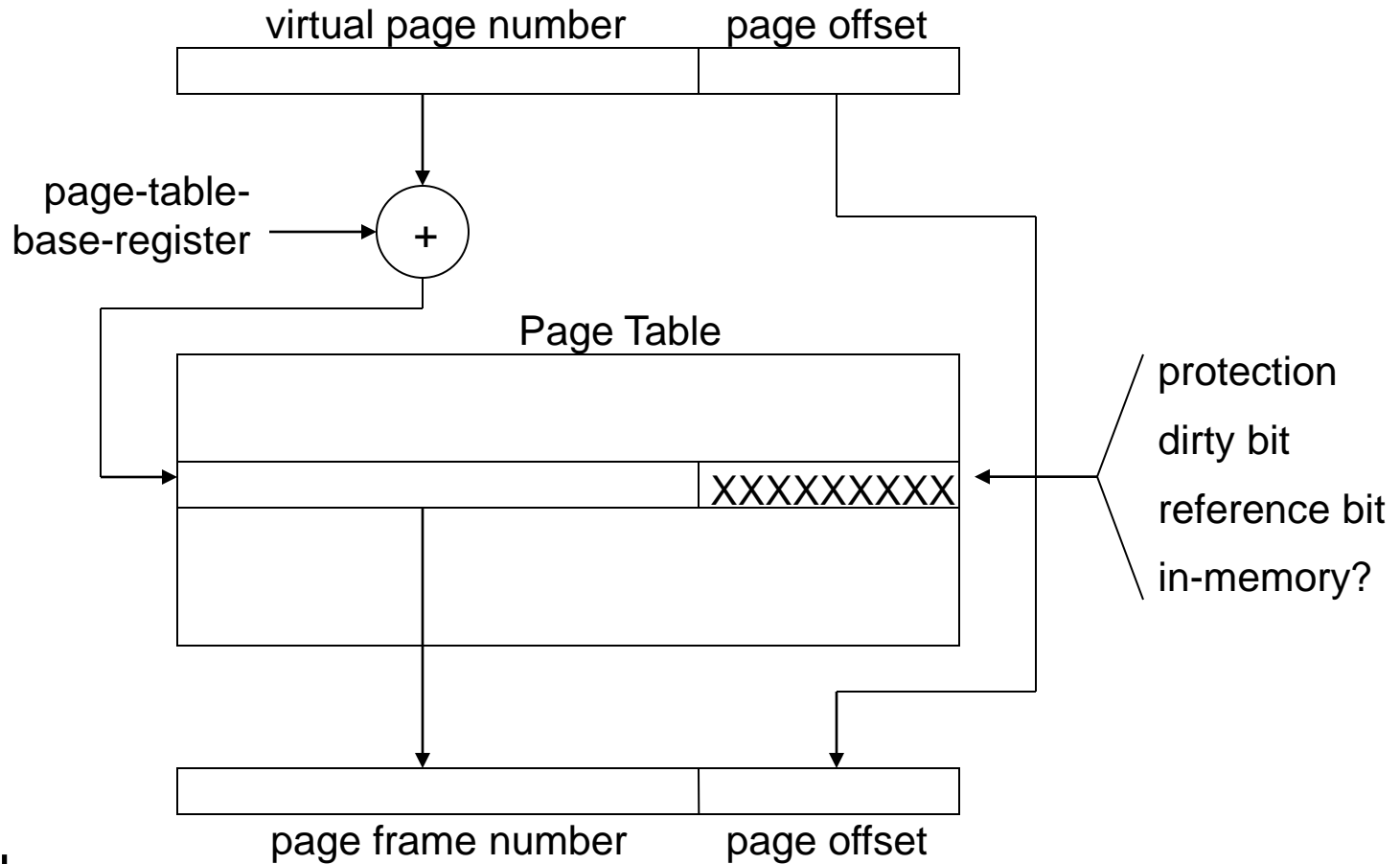

Logical Path

Two memory operations

Often two or three levels of page tables

TOO SLOW!

Address Translation

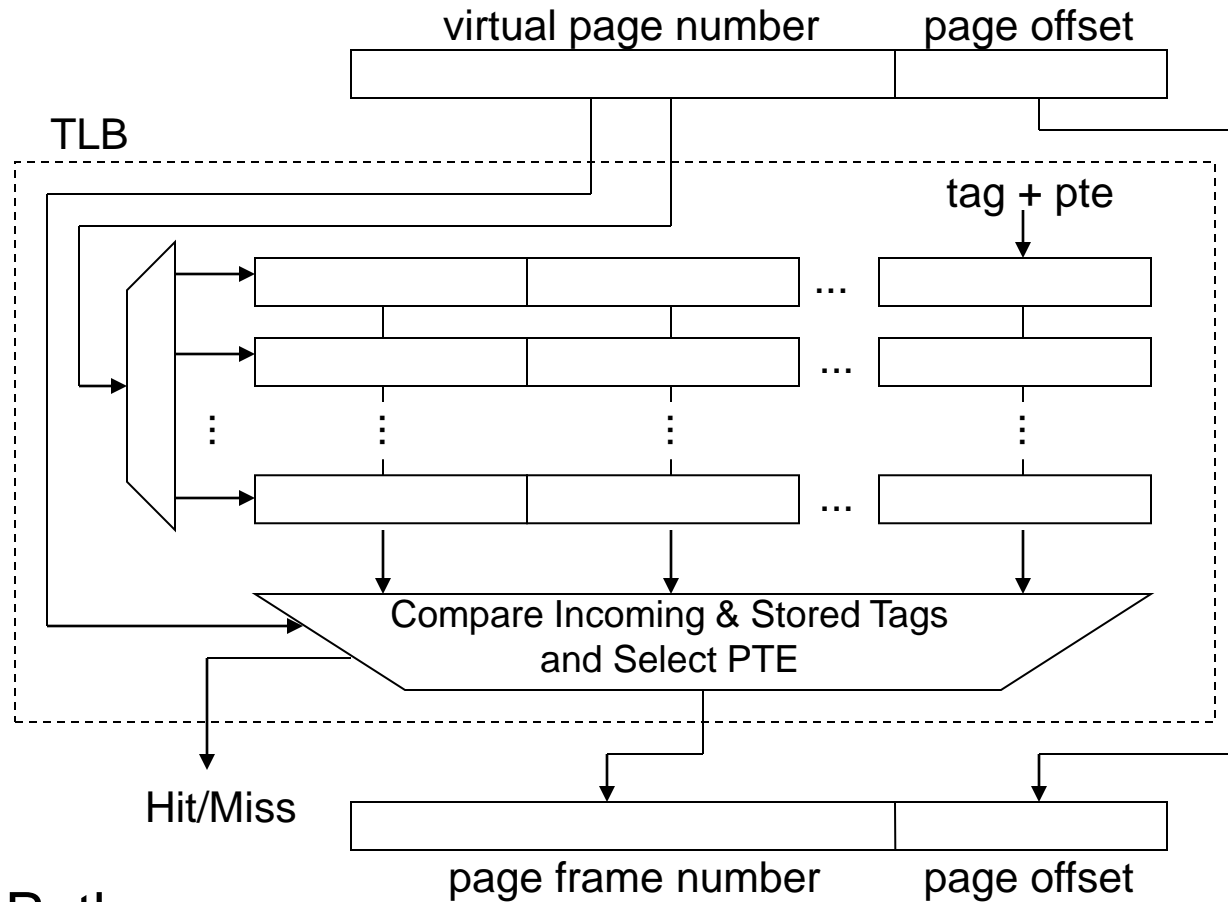

Fast Path

Translation Lookaside Buffer (TLB, TB)

A cache w/ PTEs for data

Number of entries 32 to 1024

Address Translation / Cache Interaction

Address Translation

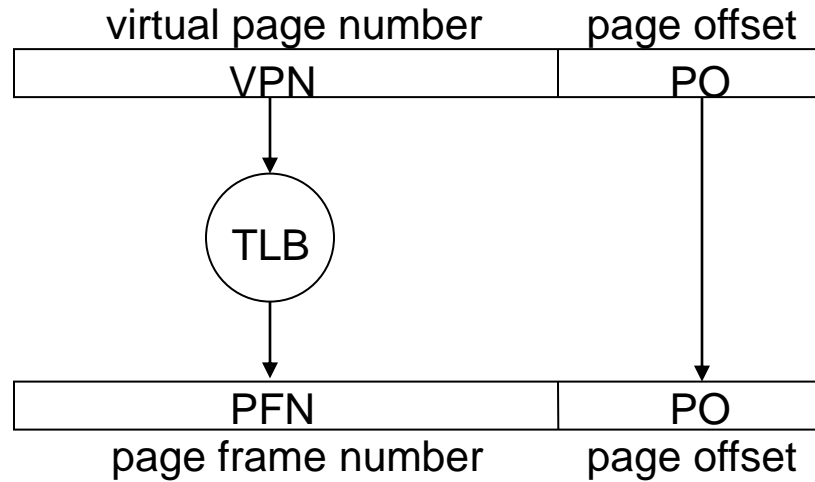

Cache Lookup

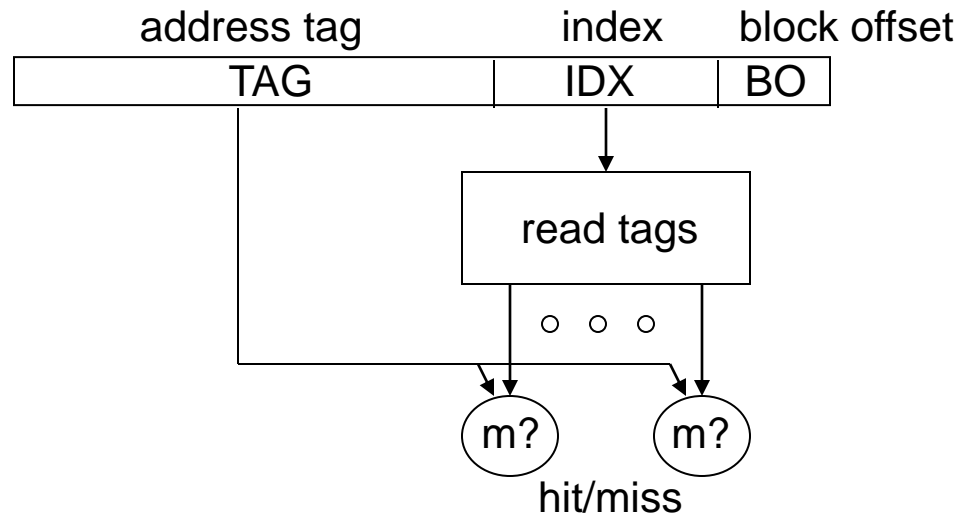

Sequential TLB Access

Address translation before cache lookup

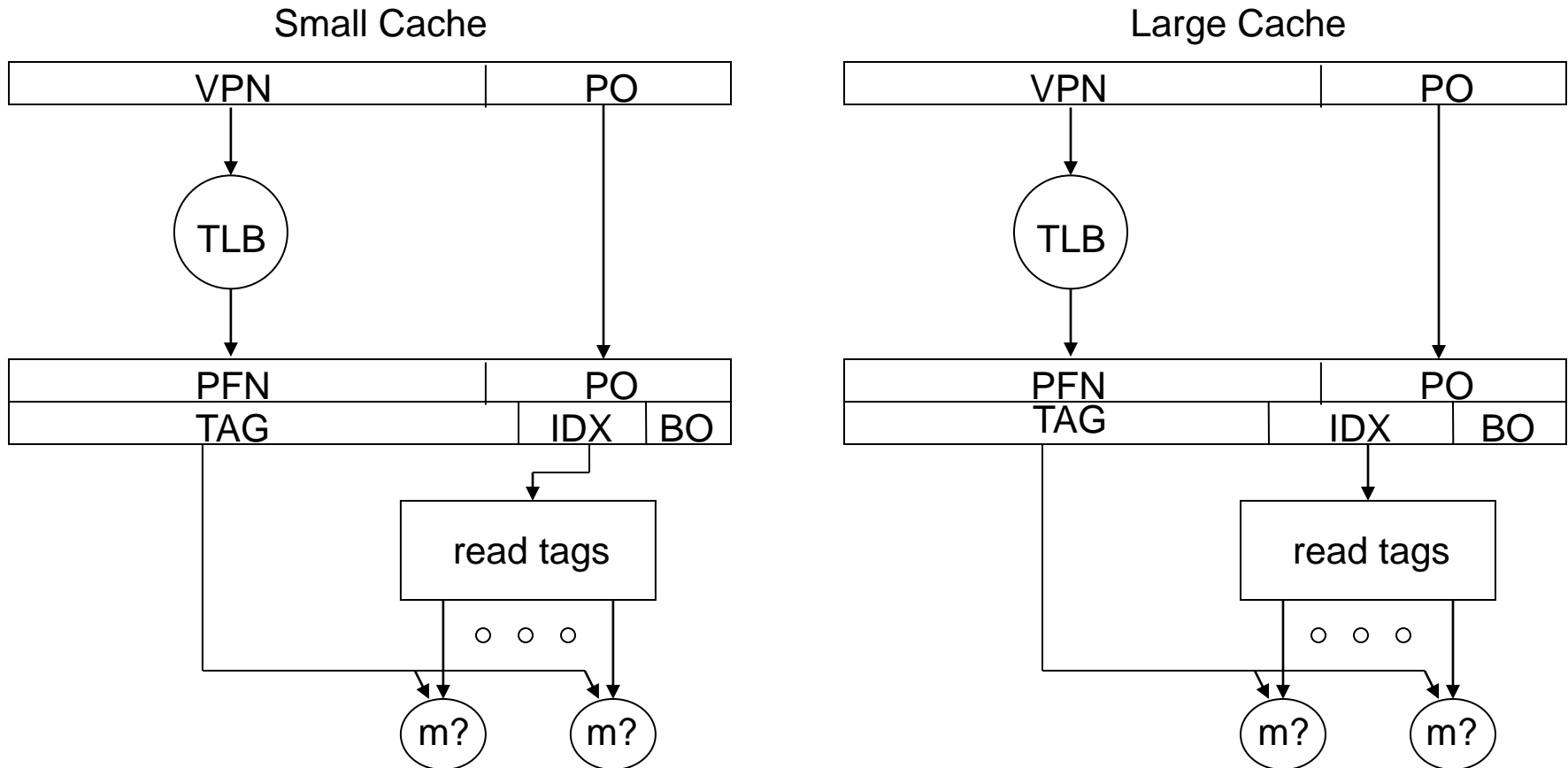

Problems

Slow

May increase cycle time, CPI, pipeline depth

Parallel TLB Access

Address translation in parallel with cache lookup

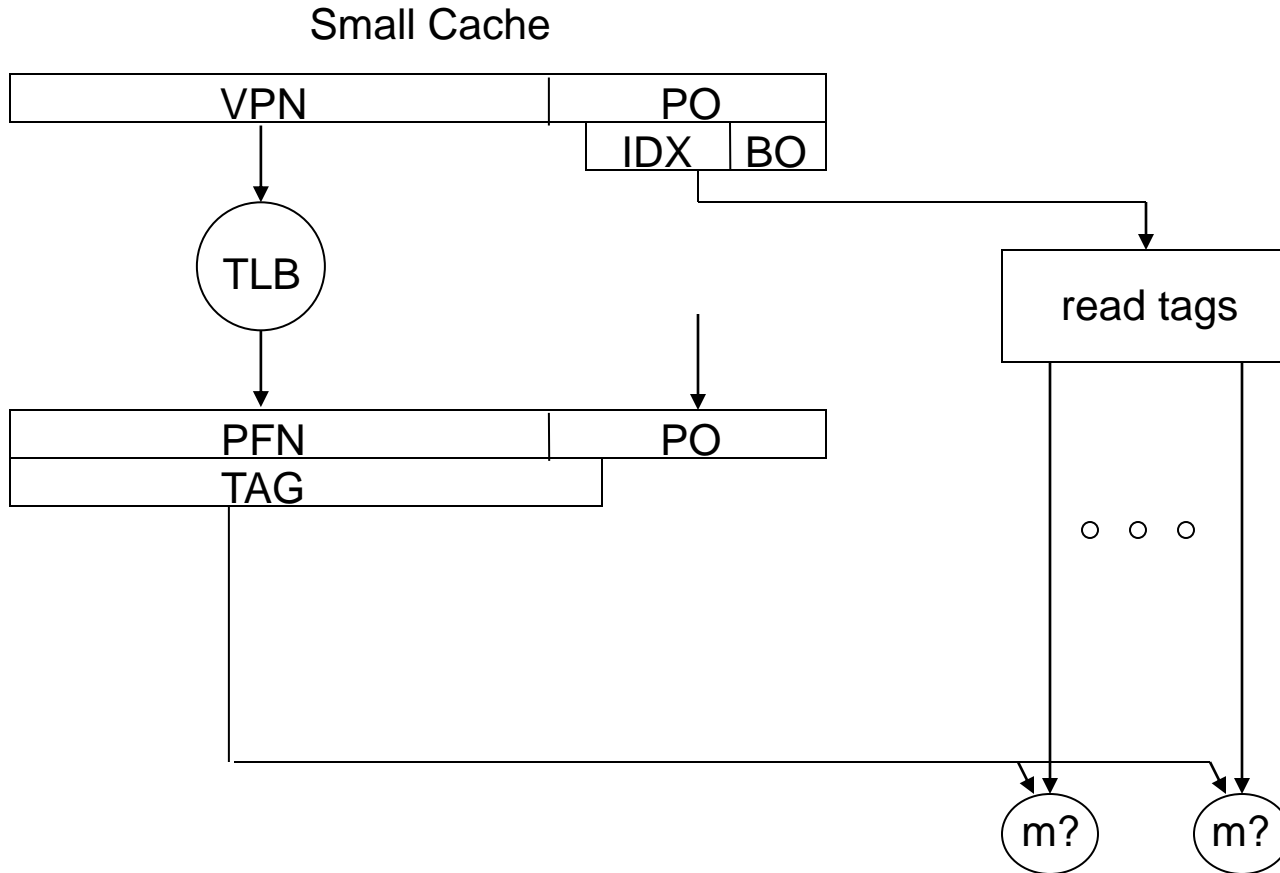

Parallel TLB Access

Address translation in parallel with cache lookup

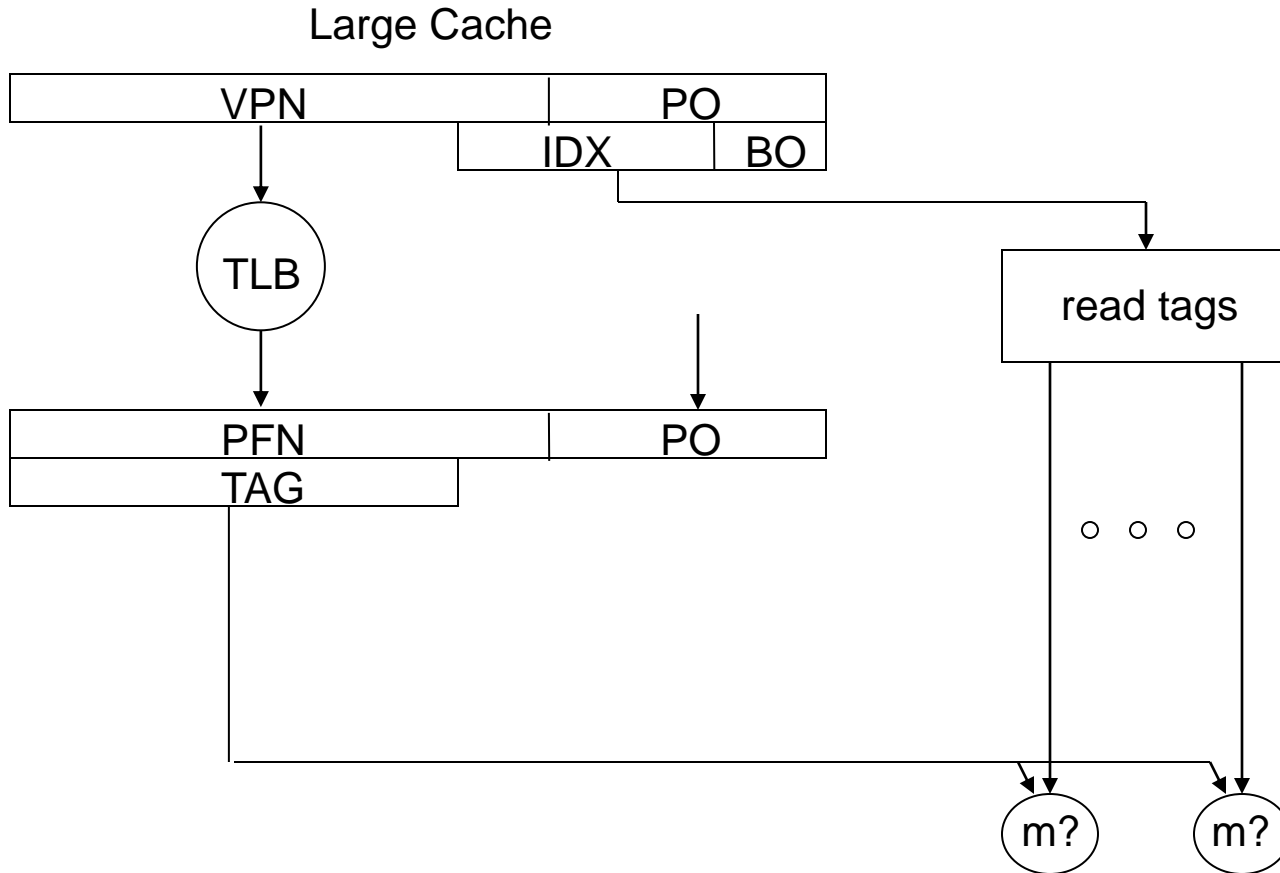

Index taken from virtual page number

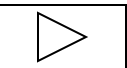

Parallel TLB Access**

Address translation in parallel with cache lookup

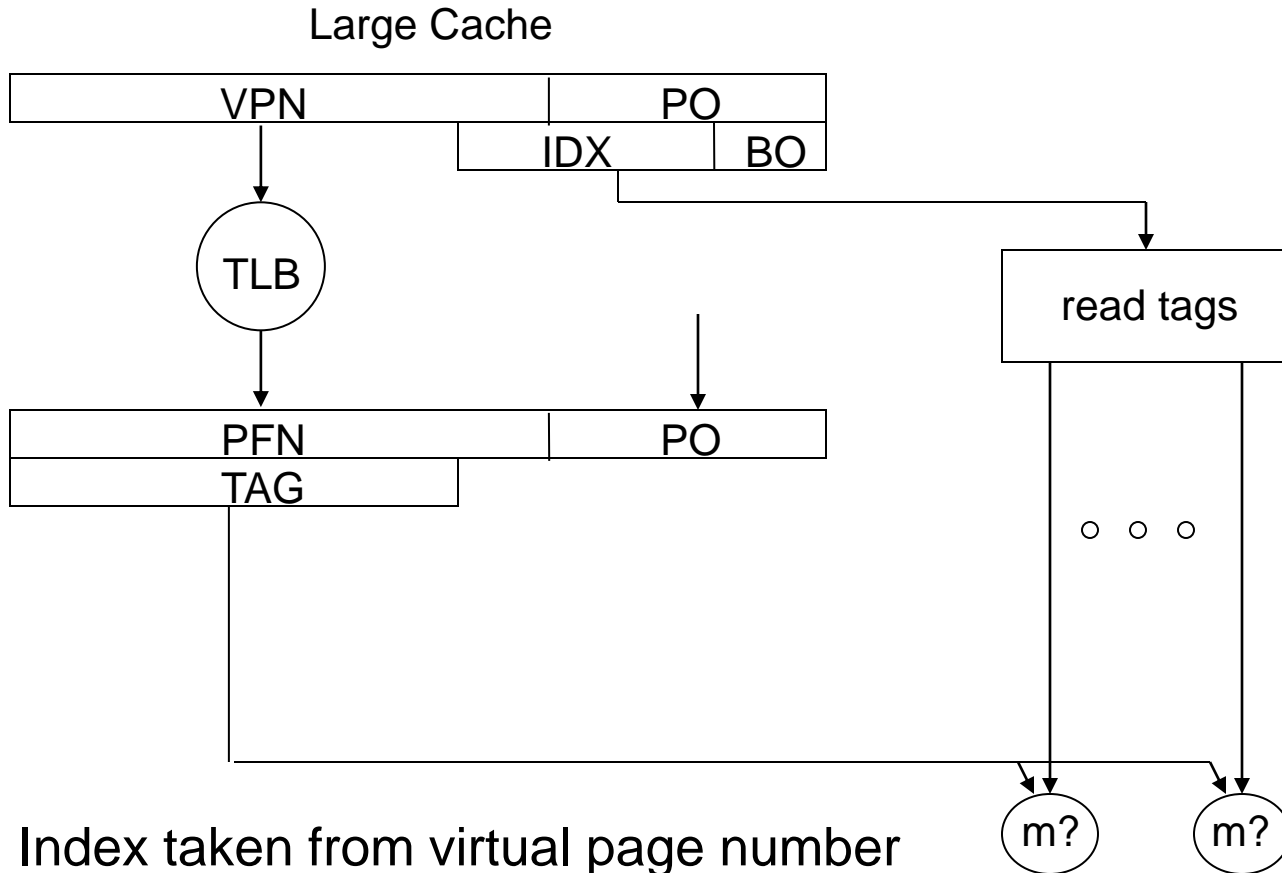

Index taken from virtual page number

Could cause problems with synonyms

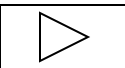

Virtual Address Synonyms

Virtual Address Space

Physical Address Space

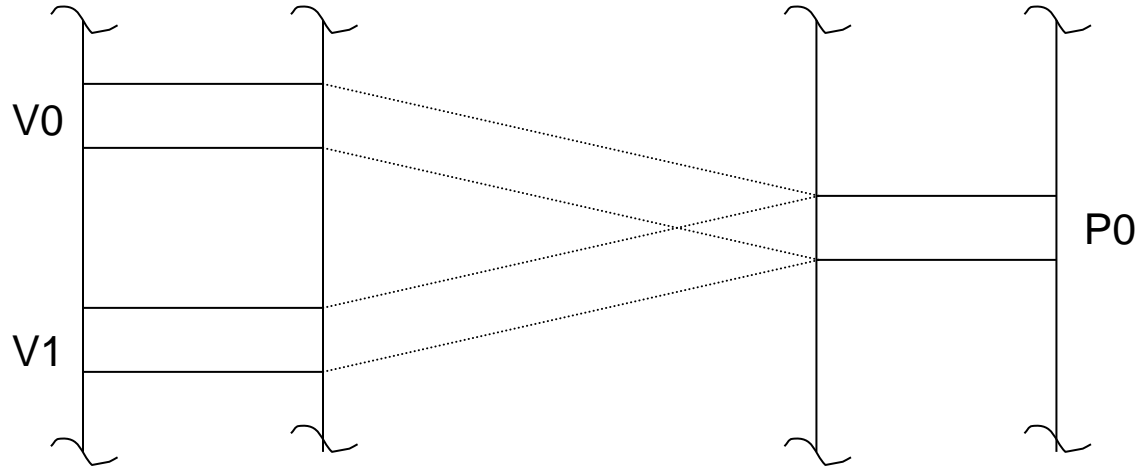

	Tag	Data
Virtual Index		
V0		
V1		

Solutions to Synonyms

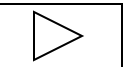

*Solutions to Synonyms***

- (1) Limit cache size to page size times assoc
Extract index from page offset

*Solutions to Synonyms***

- (1) Limit cache size to page size times assoc
Extract index from page offset
- (2) Search all sets in parallel
e.g., 64 KB 4way cache w/ 4KB pages
Search 4 sets (16 entries) in parallel

*Solutions to Synonyms***

- (1) Limit cache size to page size times assoc
Extract index from page offset
- (2) Search all sets in parallel
e.g., 64 KB 4way cache w/ 4KB pages
Search 4 sets (16 entries) in parallel
- (3) Restrict page placement in operating system
Guarantee that $\text{Index}(VA) == \text{Index}(PA)$

*Solutions to Synonyms***

- (1) Limit cache size to page size times assoc
Extract index from page offset
- (2) Search all sets in parallel
e.g., 64 KB 4way cache w/ 4KB pages
Search 4 sets (16 entries) in parallel
- (3) Restrict page placement in operating system
Guarantee that $\text{Index}(VA) == \text{Index}(PA)$
- (4) Eliminate by operating system convention
Single virtual address space
Restrictive sharing model

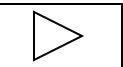

Virtual Address Cache

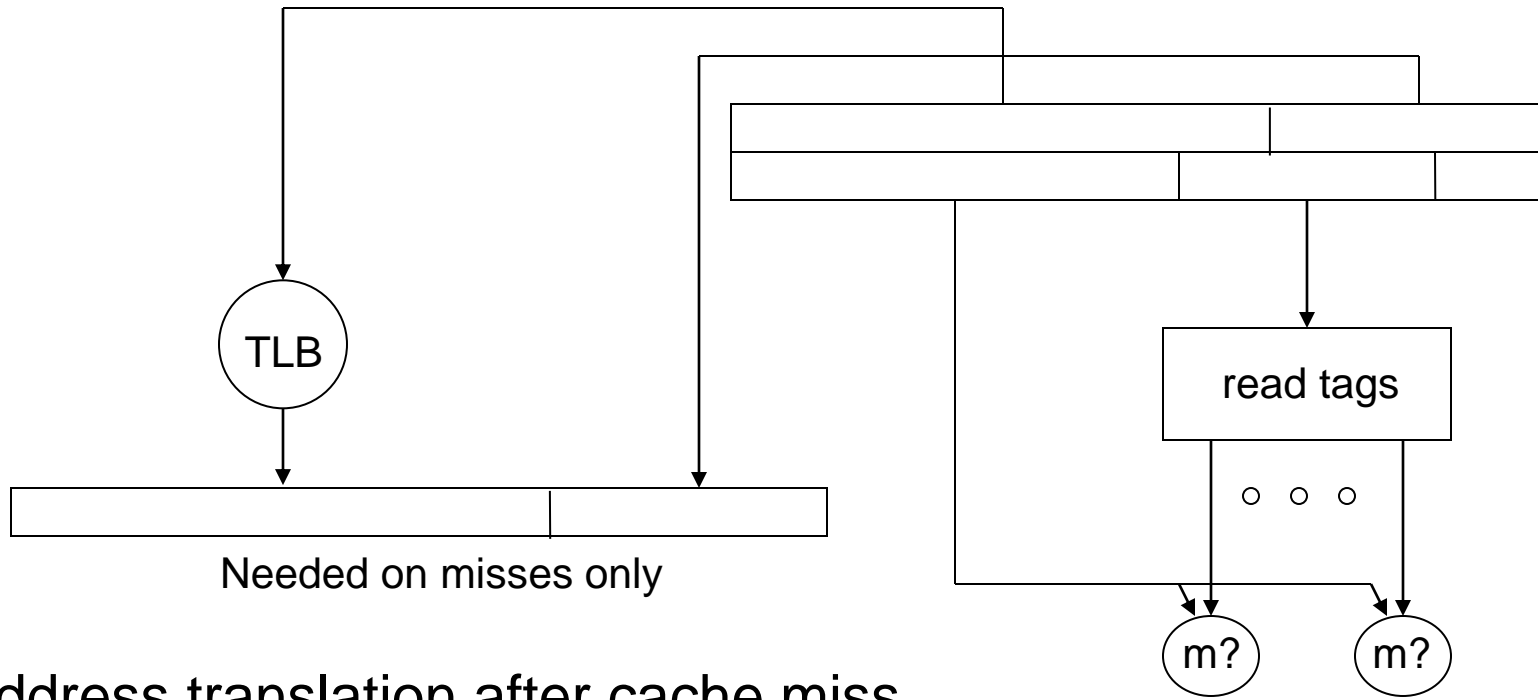

Address translation after cache miss

Implies fast lookup even for large caches

Must handle

Virtual address synonyms (aliases)

Virtual address space changes

Status and protection bit changes

Protection

Goal:

One process should not be able to interfere with the execution of another

Process model

Privileged kernel

Independent user processes

Primitives vs. Policy

Architecture provides the primitives

Operating system implements the policy

Problems arise when hardware implements policy

Protection Primitives

User vs. Kernel

- At least one privileged mode

- Usually implemented as mode bit(s)

How do we switch to kernel mode?

- Change mode and continue execution at *predetermined* location

Hardware to compare mode bits to access rights

- Access certain resources only in kernel mode

Protection Primitives, cont.

Base and Bounds

Privileged registers

Base \leq Address \leq Bounds

Pagelevel protection

Protection bits in page table entry

Cache them in TLB