

Breadth First Search, Dijkstra's Algorithm for Shortest Paths

Lecture 17

Tuesday, October 27, 2020

Algorithms & Models of Computation

CS/ECE 374, Fall 2020

17.1

Maps as graphs

Maps as graphs

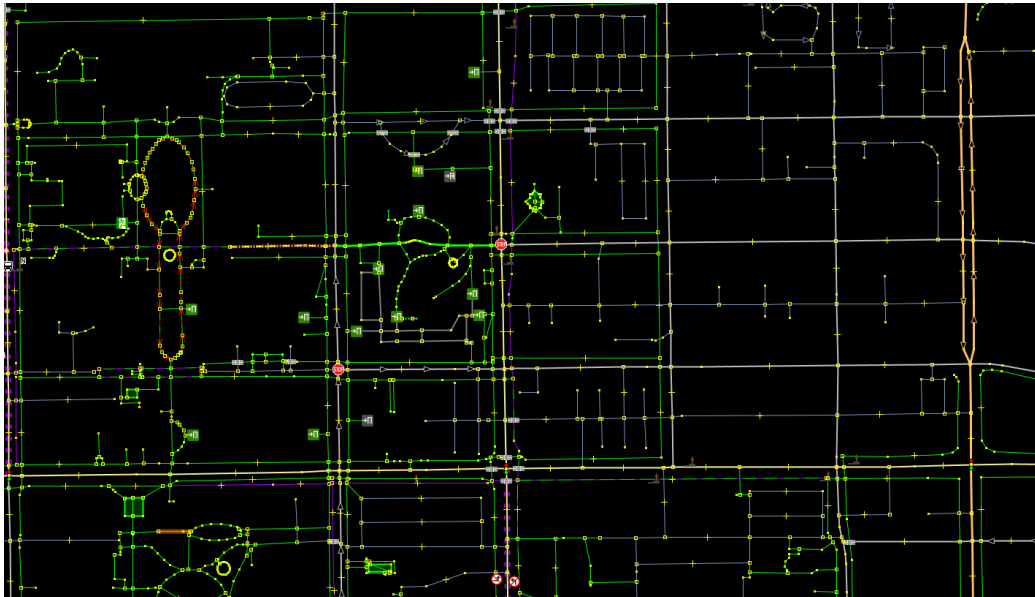

Maps as graphs II

- ① Map was downloaded from <https://www.openstreetmap.org>
- ② Open source alternative to google map.
- ③ Nice app (can download maps) + routing.
- ④ Graphs are everywhere, and easy to get and use.

THE END

...

(for now)

Algorithms & Models of Computation

CS/ECE 374, Fall 2020

17.2

Breadth First Search

Breadth First Search (BFS)

Overview

- A **BFS** is obtained from **BasicSearch** by processing edges using a queue data structure.
- B It processes the vertices in the graph in the order of their shortest distance from the vertex **s** (the start vertex).

As such...

- 1 **DFS** good for exploring graph structure
- 2 **BFS** good for exploring distances

xkcd take on DFS

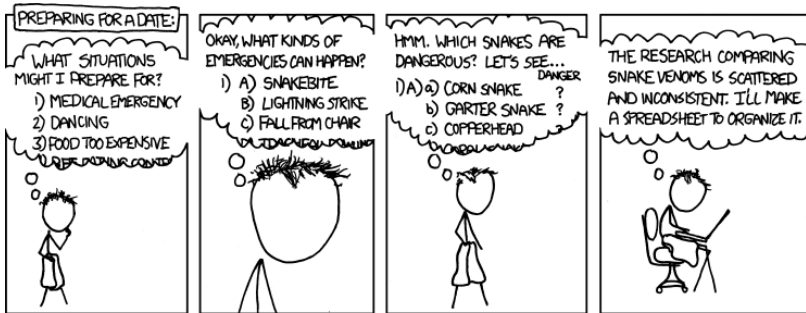

Queue Data Structure

Queues

A **queue** is a list of elements which supports the operations:

- 1 **enqueue**: Adds an element to the end of the list
- 2 **dequeue**: Removes an element from the front of the list

Elements are extracted in **first-in first-out (FIFO)** order, i.e., elements are picked in the order in which they were inserted.

BFS Algorithm

Given (undirected or directed) graph $G = (V, E)$ and node $s \in V$

BFS(s)

Mark all vertices as unvisited

Initialize search tree T to be empty

Mark vertex s as visited

set Q to be the empty queue

enqueue(Q, s)

while Q is nonempty **do**

$u =$ **dequeue**(Q)

for each vertex $v \in \text{Adj}(u)$

if v is not visited **then**

 add edge (u, v) to T

 Mark v as visited and **enqueue**(v)

Proposition

BFS(s) runs in $O(n + m)$ time.

BFS: An Example in Undirected Graphs

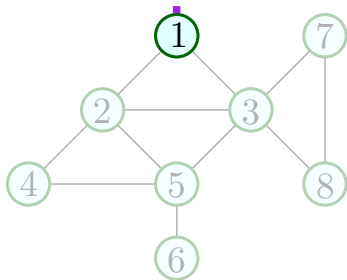
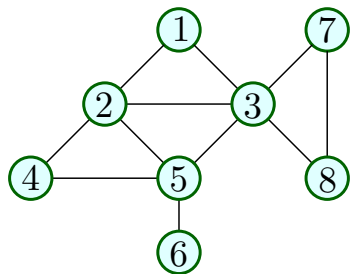

6

T1. [1]

T2. [2,3]

T3. [3,4,5]

T4. [4,5,7,8]

T5. [5,7,8]

T6. [7,8,6]

T7. [8,6]

T8. [6]

T9. []

BFS tree is the set of purple edges.

BFS: An Example in Undirected Graphs

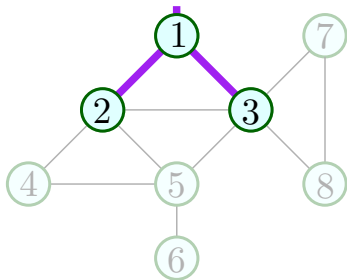
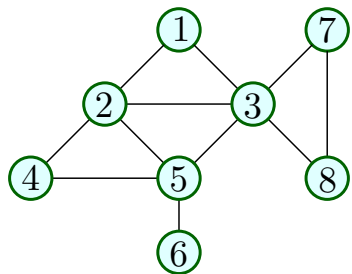

6

- T1. [1]
- T2. [2,3]
- T3. [3,4,5]

- T4. [4,5,7,8]
- T5. [5,7,8]
- T6. [7,8,6]

- T7. [8,6]
- T8. [6]
- T9. []

BFS tree is the set of purple edges.

BFS: An Example in Undirected Graphs

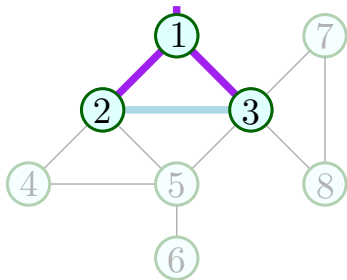
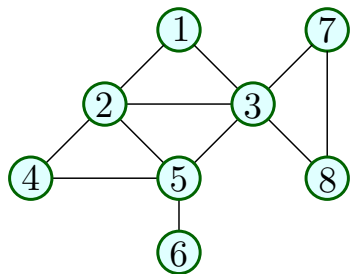

6

- T1. [1]
- T2. [2,3]
- T3. [3,4,5]

- T4. [4,5,7,8]
- T5. [5,7,8]
- T6. [7,8,6]

- T7. [8,6]
- T8. [6]
- T9. []

BFS tree is the set of purple edges.

BFS: An Example in Undirected Graphs

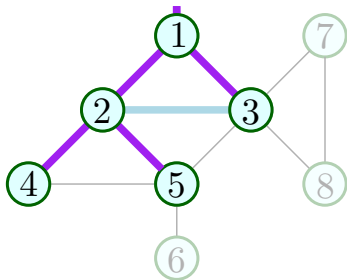
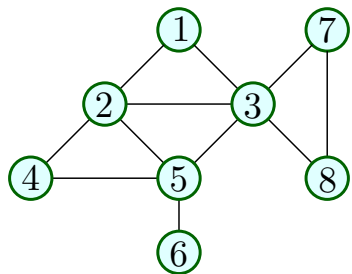

6

- T1. [1]
- T2. [2,3]
- T3. [3,4,5]

- T4. [4,5,7,8]
- T5. [5,7,8]
- T6. [7,8,6]

- T7. [8,6]
- T8. [6]
- T9. []

BFS tree is the set of purple edges.

BFS: An Example in Undirected Graphs

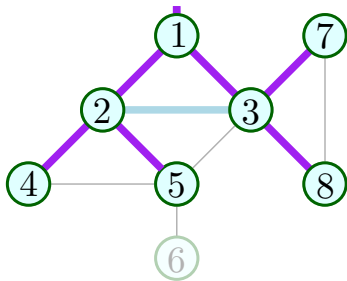
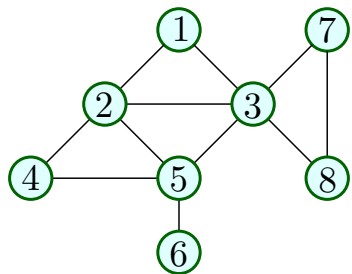

6

T1. [1]
T2. [2,3]
T3. [3,4,5]

T4. [4,5,7,8]
T5. [5,7,8]
T6. [7,8,6]

T7. [8,6]
T8. [6]
T9. []

BFS tree is the set of purple edges.

BFS: An Example in Undirected Graphs

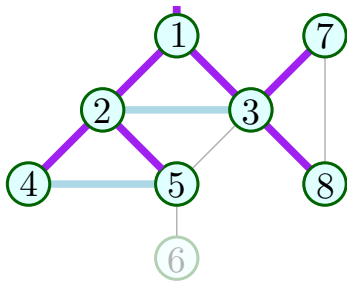
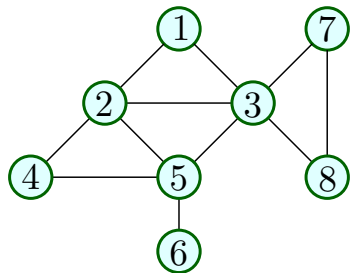

6

- T1. [1]
- T2. [2,3]
- T3. [3,4,5]

- T4. [4,5,7,8]
- T5. [5,7,8]
- T6. [7,8,6]

- T7. [8,6]
- T8. [6]
- T9. []

BFS tree is the set of purple edges.

BFS: An Example in Undirected Graphs

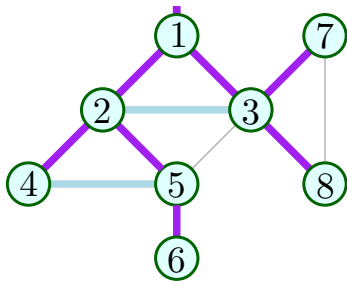
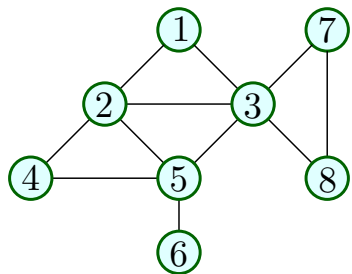

6

- T1. [1]
- T2. [2,3]
- T3. [3,4,5]

- T4. [4,5,7,8]
- T5. [5,7,8]
- T6. [7,8,6]

- T7. [8,6]
- T8. [6]
- T9. []

BFS tree is the set of purple edges.

BFS: An Example in Undirected Graphs

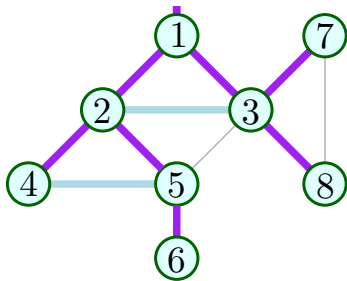
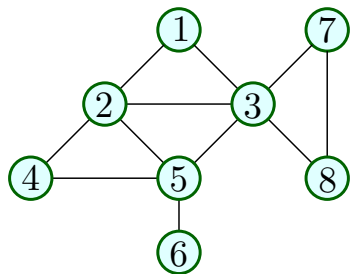

6

- T1. [1]
- T2. [2,3]
- T3. [3,4,5]

- T4. [4,5,7,8]
- T5. [5,7,8]
- T6. [7,8,6]

- T7. [8,6]
- T8. [6]
- T9. []

BFS tree is the set of purple edges.

BFS: An Example in Undirected Graphs

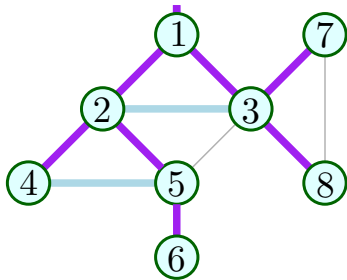
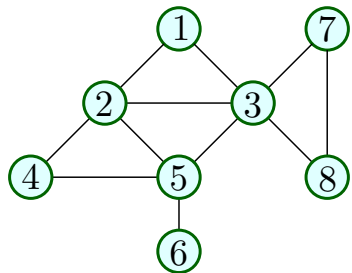

6

- T1. [1]
- T2. [2,3]
- T3. [3,4,5]

- T4. [4,5,7,8]
- T5. [5,7,8]
- T6. [7,8,6]

- T7. [8,6]
- T8. [6]
- T9. []

BFS tree is the set of purple edges.

BFS: An Example in Undirected Graphs

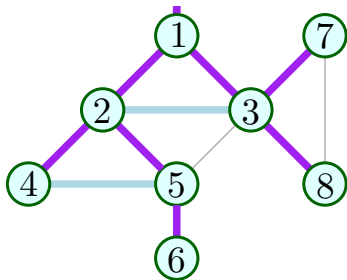
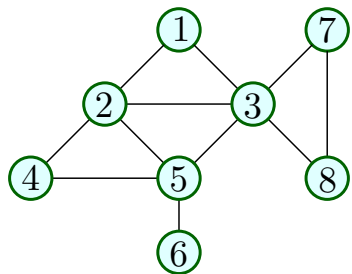

6

- T1. [1]
- T2. [2,3]
- T3. [3,4,5]

- T4. [4,5,7,8]
- T5. [5,7,8]
- T6. [7,8,6]

- T7. [8,6]
- T8. [6]
- T9. []

BFS tree is the set of purple edges.

BFS: An Example in Undirected Graphs

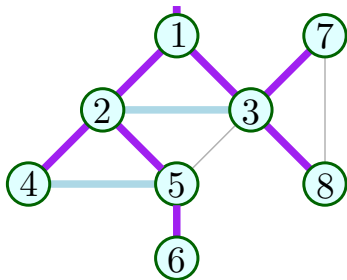
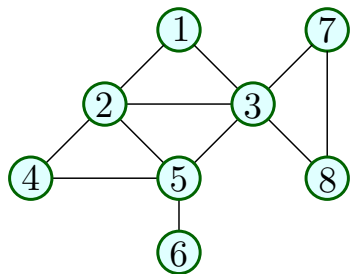

6

- T1. [1]
- T2. [2,3]
- T3. [3,4,5]

- T4. [4,5,7,8]
- T5. [5,7,8]
- T6. [7,8,6]

- T7. [8,6]
- T8. [6]
- T9. []

BFS tree is the set of purple edges.

BFS: An Example in Undirected Graphs

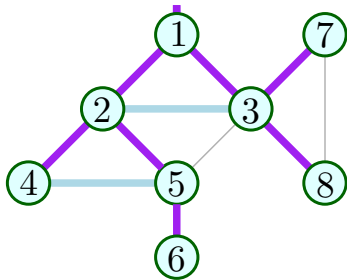
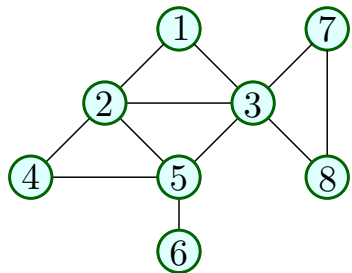

6

- T1. [1]
- T2. [2,3]
- T3. [3,4,5]

- T4. [4,5,7,8]
- T5. [5,7,8]
- T6. [7,8,6]

- T7. [8,6]
- T8. [6]
- T9. []

BFS tree is the set of purple edges.

BFS: An Example in Directed Graphs

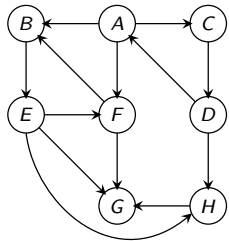

THE END

...

(for now)

17.2.1

BFS with distances and layers

BFS with distances

BFS(s)

Mark all vertices as unvisited; **for each** v **set** $\text{dist}(v) = \infty$

Initialize search tree T to be empty

Mark vertex s as visited **and set** $\text{dist}(s) = 0$

set Q to be the empty queue

enqueue(s)

while Q is nonempty **do**

$u = \text{dequeue}(Q)$

for each vertex $v \in \text{Adj}(u)$ **do**

if v is not visited **do**

 add edge (u, v) to T

 Mark v as visited, **enqueue**(v)

and set $\text{dist}(v) = \text{dist}(u) + 1$

Properties of BFS: Undirected Graphs

Theorem

The following properties hold upon termination of **BFS**(s)

- Ⓐ Search tree contains exactly the set of vertices in the connected component of s .
- Ⓑ If $\text{dist}(u) < \text{dist}(v)$ then u is visited before v .
- Ⓒ For every vertex u , $\text{dist}(u)$ is the length of a shortest path (in terms of number of edges) from s to u .
- Ⓓ If u, v are in connected component of s and $e = \{u, v\}$ is an edge of G , then $|\text{dist}(u) - \text{dist}(v)| \leq 1$.

Properties of BFS: Directed Graphs

Theorem

The following properties hold upon termination of **BFS**(s):

- Ⓐ The search tree contains exactly the set of vertices reachable from s
- Ⓑ If $\text{dist}(u) < \text{dist}(v)$ then u is visited before v
- Ⓒ For every vertex u , $\text{dist}(u)$ is indeed the length of shortest path from s to u
- Ⓓ If u is reachable from s and $e = (u, v)$ is an edge of G , then $\text{dist}(v) - \text{dist}(u) \leq 1$.
Not necessarily the case that $\text{dist}(u) - \text{dist}(v) \leq 1$.

BFS with Layers

BFSLayers(s):

Mark all vertices as unvisited and initialize T to be empty

Mark s as visited and set $L_0 = \{s\}$

$i = 0$

while L_i is not empty **do**

 initialize L_{i+1} to be an empty list

for each u in L_i **do**

for each edge $(u, v) \in \text{Adj}(u)$ **do**

 if v is not visited

 mark v as visited

 add (u, v) to tree T

 add v to L_{i+1}

$i = i + 1$

Running time: $O(n + m)$

BFS with Layers

BFSLayers(s):

Mark all vertices as unvisited and initialize T to be empty

Mark s as visited and set $L_0 = \{s\}$

$i = 0$

while L_i is not empty **do**

 initialize L_{i+1} to be an empty list

for each u in L_i **do**

for each edge $(u, v) \in \text{Adj}(u)$ **do**

 if v is not visited

 mark v as visited

 add (u, v) to tree T

 add v to L_{i+1}

$i = i + 1$

Running time: $O(n + m)$

Example

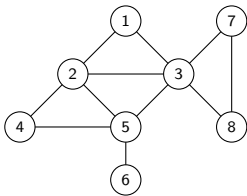

BFS with Layers: Properties

Proposition

The following properties hold on termination of **BFS**Layers(s).

- 1 **BFS**Layers(s) outputs a **BFS** tree
- 2 L_i is the set of vertices at distance exactly i from s
- 3 If G is undirected, each edge $e = \{u, v\}$ is one of three types:
 - 1 tree edge between two consecutive layers
 - 2 non-tree forward/backward edge between two consecutive layers
 - 3 non-tree cross-edge with both u, v in same layer
 - 4 \implies Every edge in the graph is either between two vertices that are either (i) in the same layer, or (ii) in two consecutive layers.

Example

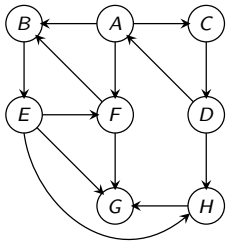

BFS with Layers: Properties

For directed graphs

Proposition

The following properties hold on termination of **BFSLayers**(s), if G is directed.
For each edge $e = (u, v)$ is one of four types:

- 1 a tree edge between consecutive layers, $u \in L_i, v \in L_{i+1}$ for some $i \geq 0$
- 2 a non-tree forward edge between consecutive layers
- 3 a non-tree backward edge
- 4 a cross-edge with both u, v in same layer

THE END

...

(for now)

17.3

Shortest Paths and Dijkstra's Algorithm

17.3.1

Problem definition

Shortest Path Problems

Shortest Path Problems

Input A (undirected or directed) graph $G = (V, E)$ with edge lengths (or costs).
For edge $e = (u, v)$, $\ell(e) = \ell(u, v)$ is its length.

- 1 Given nodes s, t find shortest path from s to t .
- 2 Given node s find shortest path from s to all other nodes.
- 3 Find shortest paths for all pairs of nodes.

Many applications!

Shortest Path Problems

Shortest Path Problems

Input A (undirected or directed) graph $G = (V, E)$ with edge lengths (or costs).
For edge $e = (u, v)$, $\ell(e) = \ell(u, v)$ is its length.

- 1 Given nodes s, t find shortest path from s to t .
- 2 Given node s find shortest path from s to all other nodes.
- 3 Find shortest paths for all pairs of nodes.

Many applications!

Single-Source Shortest Paths:

Non-Negative Edge Lengths

1 Single-Source Shortest Path Problems

- 1 **Input:** A (undirected or directed) graph $G = (V, E)$ with **non-negative** edge lengths. For edge $e = (u, v)$, $\ell(e) = \ell(u, v)$ is its length.
- 2 Given nodes s, t find shortest path from s to t .
- 3 Given node s find shortest path from s to all other nodes.

2

- 1 Restrict attention to directed graphs
- 2 Undirected graph problem can be reduced to directed graph problem - how?
 - 1 Given undirected graph G , create a new directed graph G' by replacing each edge $\{u, v\}$ in G by (u, v) and (v, u) in G' .
 - 2 set $\ell(u, v) = \ell(v, u) = \ell(\{u, v\})$
 - 3 Exercise: show reduction works. **Relies on non-negativity!**

Single-Source Shortest Paths:

Non-Negative Edge Lengths

① Single-Source Shortest Path Problems

- ① **Input:** A (undirected or directed) graph $G = (V, E)$ with **non-negative** edge lengths. For edge $e = (u, v)$, $\ell(e) = \ell(u, v)$ is its length.
- ② Given nodes s, t find shortest path from s to t .
- ③ Given node s find shortest path from s to all other nodes.

②

- ① Restrict attention to directed graphs
- ② Undirected graph problem can be reduced to directed graph problem - how?
 - ① Given undirected graph G , create a new directed graph G' by replacing each edge $\{u, v\}$ in G by (u, v) and (v, u) in G' .
 - ② set $\ell(u, v) = \ell(v, u) = \ell(\{u, v\})$
 - ③ Exercise: show reduction works. **Relies on non-negativity!**

Single-Source Shortest Paths:

Non-Negative Edge Lengths

① Single-Source Shortest Path Problems

- ① **Input:** A (undirected or directed) graph $G = (V, E)$ with **non-negative** edge lengths. For edge $e = (u, v)$, $\ell(e) = \ell(u, v)$ is its length.
- ② Given nodes s, t find shortest path from s to t .
- ③ Given node s find shortest path from s to all other nodes.

②

- ① Restrict attention to directed graphs
- ② Undirected graph problem can be reduced to directed graph problem - how?
 - ① Given undirected graph G , create a new directed graph G' by replacing each edge $\{u, v\}$ in G by (u, v) and (v, u) in G' .
 - ② set $\ell(u, v) = \ell(v, u) = \ell(\{u, v\})$
 - ③ Exercise: show reduction works. **Relies on non-negativity!**

THE END

...

(for now)

17.3.2

Shortest path via continuous Dijkstra

Animation

See animation here:

<https://youtu.be/t7UjtzqIXSA>

Also:

<https://youtu.be/pktZ1Q0A67s>

THE END

...

(for now)

17.3.3

Shortest path in the weighted case using
BFS

Single-Source Shortest Paths via BFS

① **Special case:** All edge lengths are 1.

① Run **BFS**(s) to get shortest path distances from s to all other nodes.

② $O(m + n)$ time algorithm.

② **Special case:** Suppose $\ell(e)$ is an integer for all e ?

Can we use **BFS**? Reduce to unit edge-length problem by placing $\ell(e) - 1$ dummy nodes on e .

Single-Source Shortest Paths via BFS

- 1 **Special case:** All edge lengths are 1.
 - 1 Run **BFS**(s) to get shortest path distances from s to all other nodes.
 - 2 $O(m + n)$ time algorithm.
- 2 **Special case:** Suppose $\ell(e)$ is an integer for all e ?
Can we use **BFS**? Reduce to unit edge-length problem by placing $\ell(e) - 1$ dummy nodes on e .

Single-Source Shortest Paths via BFS

① **Special case:** All edge lengths are 1.

① Run **BFS**(s) to get shortest path distances from s to all other nodes.

② $O(m + n)$ time algorithm.

② **Special case:** Suppose $\ell(e)$ is an integer for all e ?

Can we use **BFS**? Reduce to unit edge-length problem by placing $\ell(e) - 1$ dummy nodes on e .

Single-Source Shortest Paths via BFS

- ① **Special case:** All edge lengths are 1.
 - ① Run **BFS**(s) to get shortest path distances from s to all other nodes.
 - ② $O(m + n)$ time algorithm.
- ② **Special case:** Suppose $\ell(e)$ is an integer for all e ?
Can we use **BFS**? Reduce to unit edge-length problem by placing $\ell(e) - 1$ dummy nodes on e .

Example of edge refinement

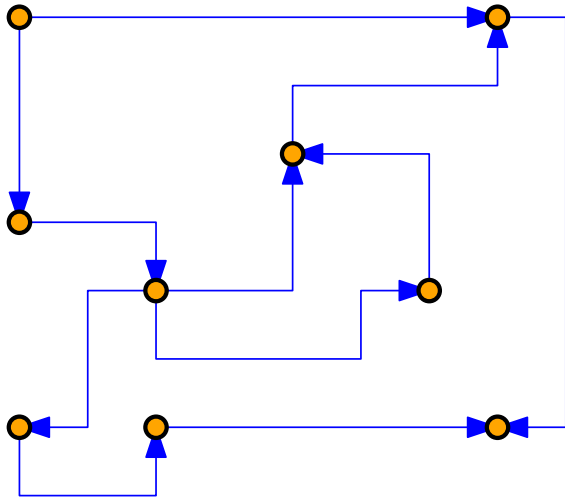

Example of edge refinement

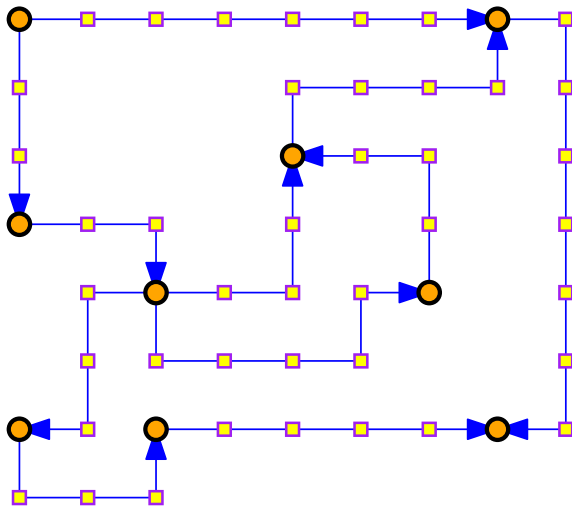

Example of edge refinement

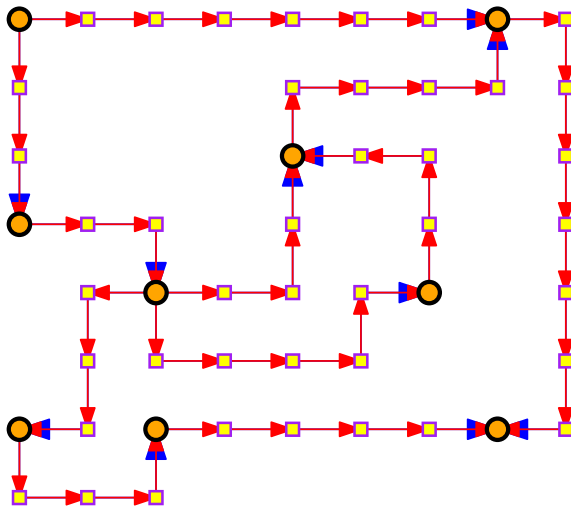

Shortest path using BFS

Let $L = \max_e \ell(e)$. New graph has $O(mL)$ edges and $O(mL + n)$ nodes. **BFS** takes $O(mL + n)$ time. Not efficient if L is large.

Why does BFS kind of works?

Why does **BFS** work?

BFS(s) explores nodes in increasing distance from s

Why does BFS kind of works?

Why does **BFS** work?

BFS(s) explores nodes in increasing distance from s

THE END

...

(for now)

17.3.4

On the hereditary nature of shortest paths

You can not shortcut a shortest path

Lemma

G : directed graph with non-negative edge lengths.

$\text{dist}(s, v)$: shortest path length from s to v .

If $s = v_0 \rightarrow v_1 \rightarrow v_2 \rightarrow \dots \rightarrow v_k$ shortest path from s to v_k then for any $0 \leq i < j \leq k$:

$v_i \rightarrow v_{i+1} \rightarrow \dots \rightarrow v_j$ is shortest path from v_i to v_j

Proof.

Suppose not. Then for some $0 \leq i < j \leq k$ there is a path P' from v_i to v_j of length strictly less than that of $s = v_i \rightarrow v_{i+1} \rightarrow \dots \rightarrow v_j$. Then the path

$$s = v_0 \rightarrow v_1 \rightarrow \dots \rightarrow v_i \bullet P' \bullet v_j \rightarrow v_{j+1} \rightarrow \dots \rightarrow v_k$$

is a strictly shorter path from s to v_k than $s = v_0 \rightarrow v_1 \dots \rightarrow v_k$. □

You can not shortcut a shortest path

Lemma

G : directed graph with non-negative edge lengths.

$\text{dist}(s, v)$: shortest path length from s to v .

If $s = v_0 \rightarrow v_1 \rightarrow v_2 \rightarrow \dots \rightarrow v_k$ shortest path from s to v_k then for any $0 \leq i < j \leq k$:

$v_i \rightarrow v_{i+1} \rightarrow \dots \rightarrow v_j$ is shortest path from v_i to v_j

Proof.

Suppose not. Then for some $0 \leq i < j \leq k$ there is a path P' from v_i to v_j of length strictly less than that of $s = v_i \rightarrow v_{i+1} \rightarrow \dots \rightarrow v_j$. Then the path

$$s = v_0 \rightarrow v_1 \rightarrow \dots \rightarrow v_i \bullet P' \bullet v_j \rightarrow v_{j+1} \rightarrow \dots \rightarrow v_k$$

is a strictly shorter path from s to v_k than $s = v_0 \rightarrow v_1 \dots \rightarrow v_k$. □

A proof by picture

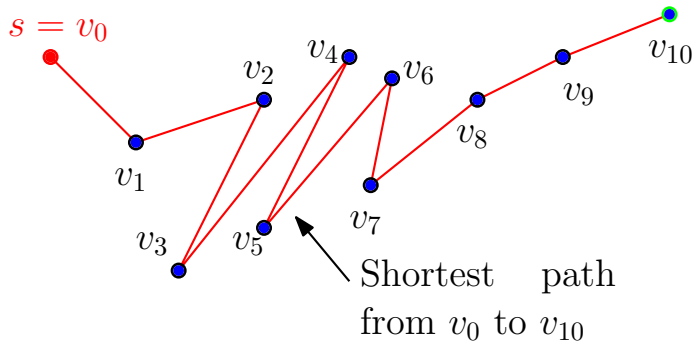

A proof by picture

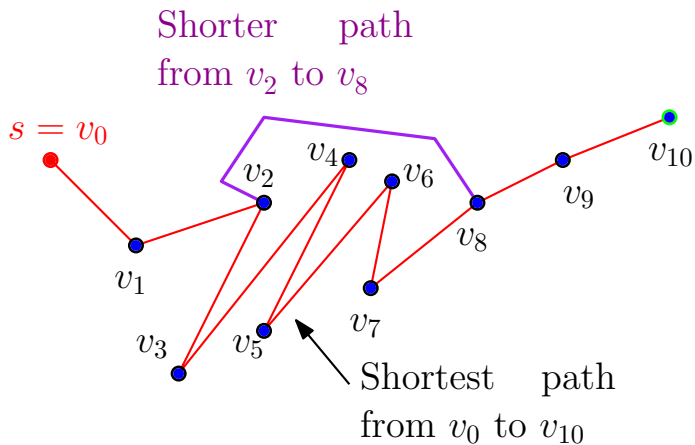

A proof by picture

A shorter path
from v_0 to v_{10} .
A contradiction.

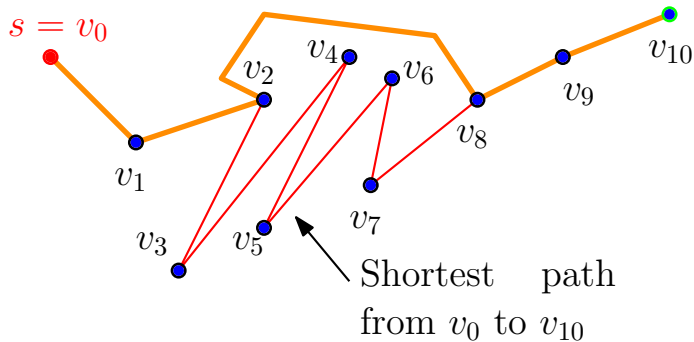

What we really need...

Corollary

G : directed graph with non-negative edge lengths.

$\text{dist}(s, v)$: shortest path length from s to v .

If $s = v_0 \rightarrow v_1 \rightarrow v_2 \rightarrow \dots \rightarrow v_k$ shortest path from s to v_k then for any $0 \leq i \leq k$:

- 1 $s = v_0 \rightarrow v_1 \rightarrow v_2 \rightarrow \dots \rightarrow v_i$ is shortest path from s to v_i
- 2 $\text{dist}(s, v_i) \leq \text{dist}(s, v_k)$. *Relies on non-neg edge lengths.*

THE END

...

(for now)

17.3.5

The basic algorithm: Find the i th closest vertex

A Basic Strategy

Explore vertices in increasing order of distance from s :

(For simplicity assume that nodes are at different distances from s and that no edge has zero length)

```
Initialize for each node  $v$ ,  $\text{dist}(s, v) = \infty$ 
Initialize  $X = \{s\}$ ,
for  $i = 2$  to  $|V|$  do
    (* Invariant:  $X$  contains the  $i - 1$  closest nodes to  $s$  *)
    Among nodes in  $V - X$ , find the node  $v$  that is the
         $i$ th closest to  $s$ 
    Update  $\text{dist}(s, v)$ 
     $X = X \cup \{v\}$ 
```

How can we implement the step in the for loop?

A Basic Strategy

Explore vertices in increasing order of distance from s :

(For simplicity assume that nodes are at different distances from s and that no edge has zero length)

```
Initialize for each node  $v$ ,  $\text{dist}(s, v) = \infty$   
Initialize  $X = \{s\}$ ,  
for  $i = 2$  to  $|V|$  do  
    (* Invariant:  $X$  contains the  $i - 1$  closest nodes to  $s$  *)  
    Among nodes in  $V - X$ , find the node  $v$  that is the  
         $i$ th closest to  $s$   
    Update  $\text{dist}(s, v)$   
     $X = X \cup \{v\}$ 
```

How can we implement the step in the for loop?

Finding the i th closest node

- 1 X contains the $i - 1$ closest nodes to s
- 2 Want to find the i th closest node from $V - X$.

What do we know about the i th closest node?

Claim

Let P be a shortest path from s to v where v is the i th closest node. Then, all intermediate nodes in P belong to X .

Proof.

If P had an intermediate node u not in X then u will be closer to s than v . Implies v is not the i th closest node to s - recall that X already has the $i - 1$ closest nodes. \square

Finding the i th closest node

- 1 X contains the $i - 1$ closest nodes to s
- 2 Want to find the i th closest node from $V - X$.

What do we know about the i th closest node?

Claim

Let P be a shortest path from s to v where v is the i th closest node. Then, all intermediate nodes in P belong to X .

Proof.

If P had an intermediate node u not in X then u will be closer to s than v . Implies v is not the i th closest node to s - recall that X already has the $i - 1$ closest nodes. \square

Finding the i th closest node

- 1 X contains the $i - 1$ closest nodes to s
- 2 Want to find the i th closest node from $V - X$.

What do we know about the i th closest node?

Claim

Let P be a shortest path from s to v where v is the i th closest node. Then, all intermediate nodes in P belong to X .

Proof.

If P had an intermediate node u not in X then u will be closer to s than v . Implies v is not the i th closest node to s - recall that X already has the $i - 1$ closest nodes. \square

Finding the i th closest node repeatedly

An example

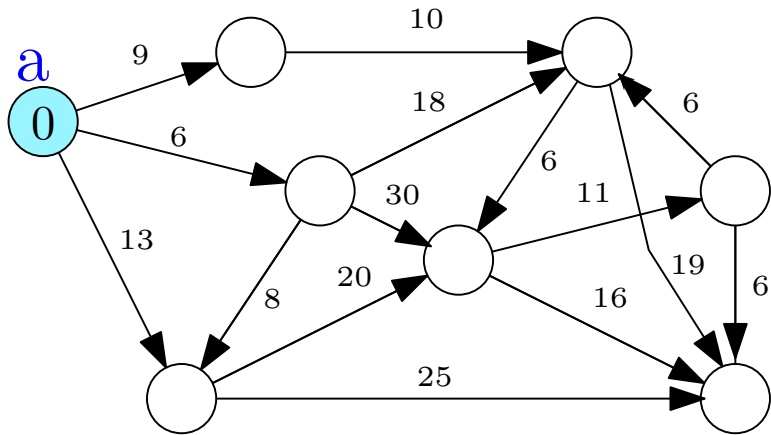

Finding the i th closest node repeatedly

An example

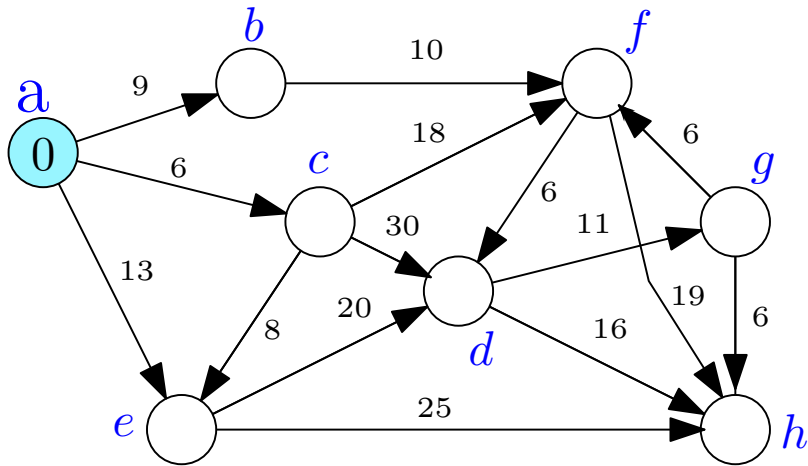

Finding the i th closest node repeatedly

An example

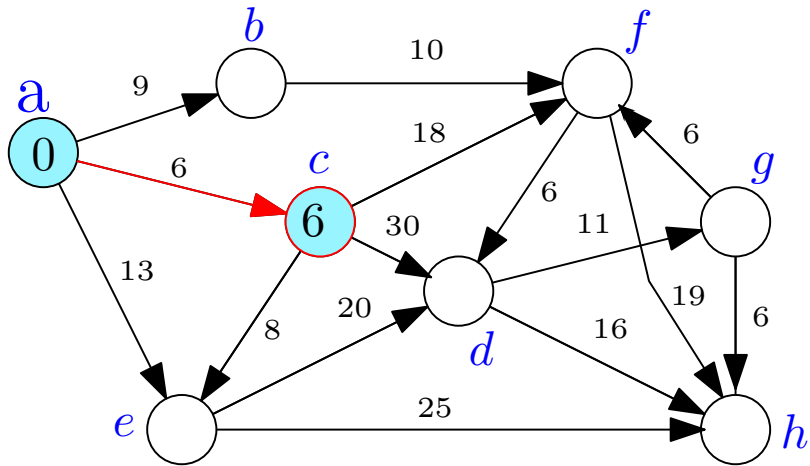

Finding the i th closest node repeatedly

An example

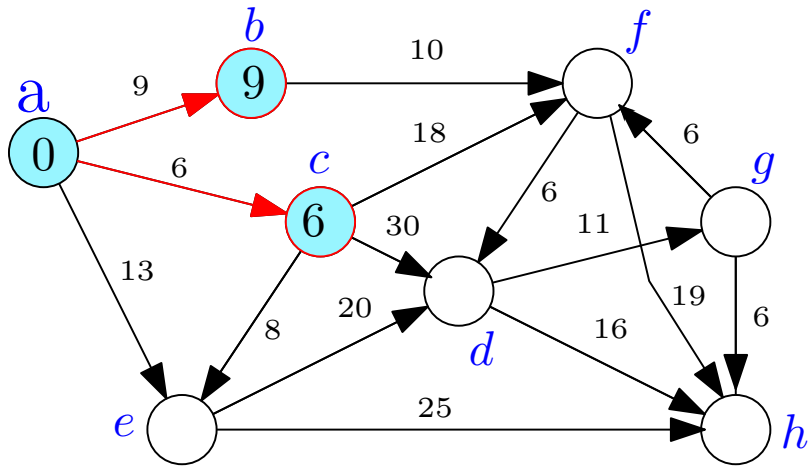

Finding the i th closest node repeatedly

An example

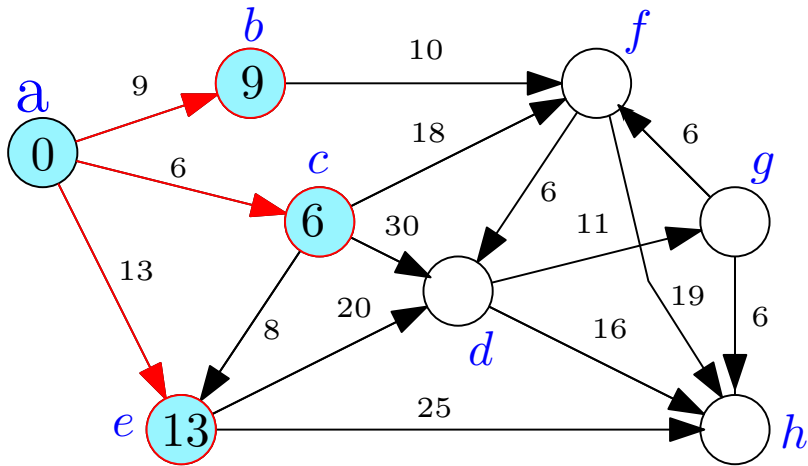

Finding the i th closest node repeatedly

An example

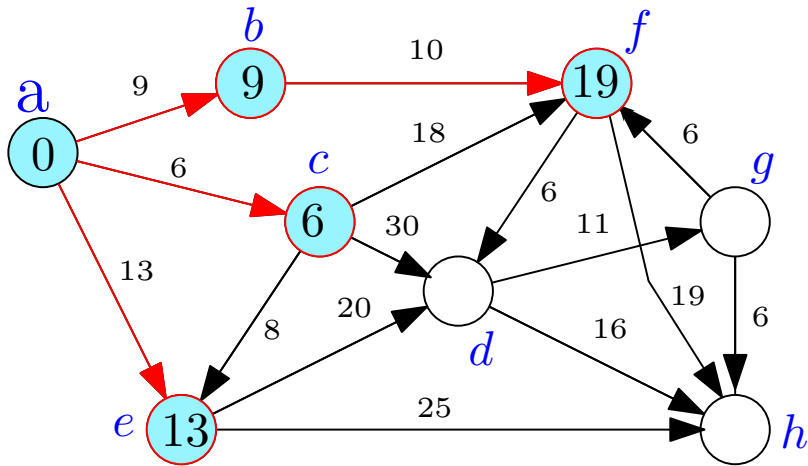

Finding the i th closest node repeatedly

An example

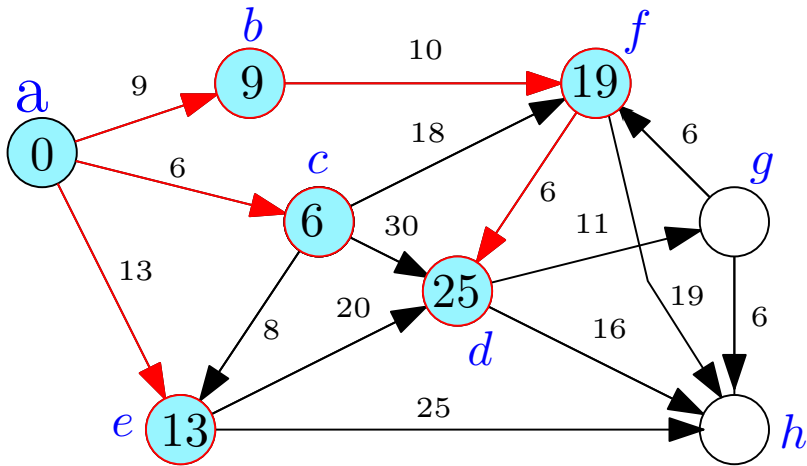

Finding the i th closest node repeatedly

An example

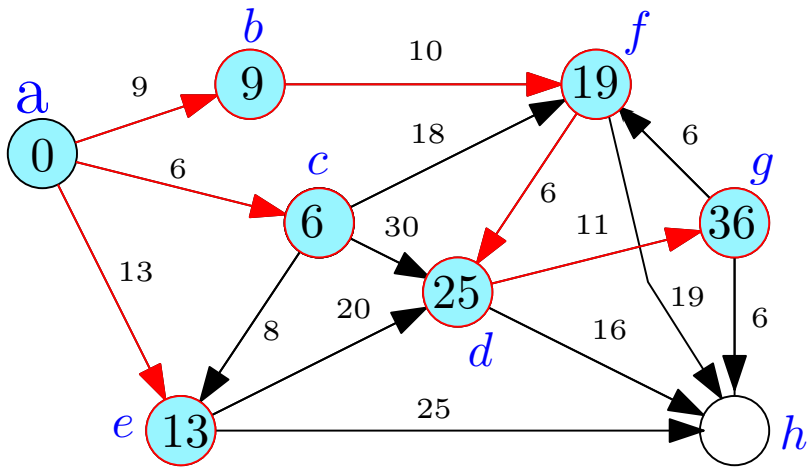

Finding the i th closest node repeatedly

An example

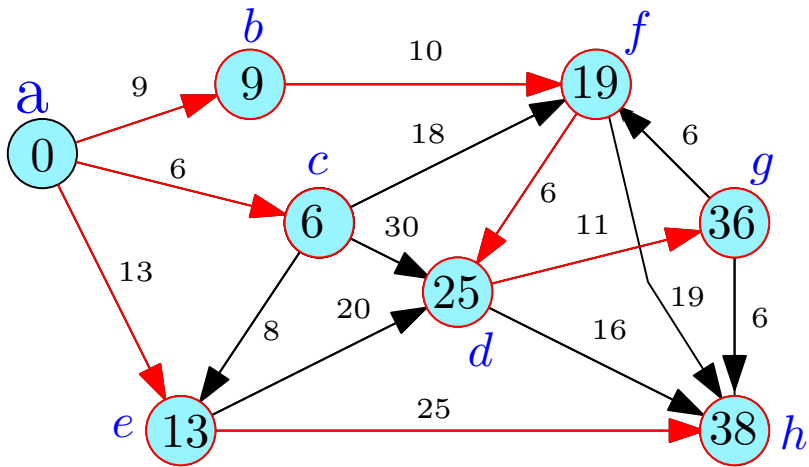

Finding the i th closest node

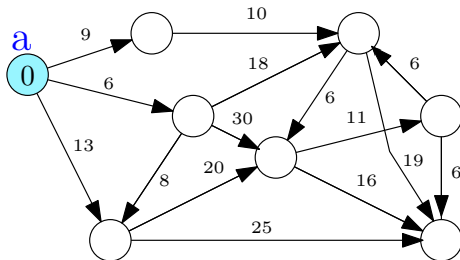

Corollary

The i th closest node is adjacent to X .

Summary

Proved that the basic algorithm is (intuitively) correct...

...but is missing details

...and how to implement efficiently?

THE END

...

(for now)

17.3.6

How to compute the i th closest vertex?

Finding the i th closest node

- 1 X contains the $i - 1$ closest nodes to s
- 2 Want to find the i th closest node from $V - X$.
- 1 For each $u \in V - X$ let $P(s, u, X)$ be a shortest path from s to u using only nodes in X as intermediate vertices.
- 2 Let $d'(s, u)$ be the length of $P(s, u, X)$

Observations: for each $u \in V - X$,

- 1 $\text{dist}(s, u) \leq d'(s, u)$ since we are constraining the paths
- 2 $d'(s, u) = \min_{t \in X} (\text{dist}(s, t) + \ell(t, u))$ - Why?

Lemma (d' has the right value for i th vertex)

If v is the i th closest node to s , then $d'(s, v) = \text{dist}(s, v)$.

Finding the i th closest node

- 1 X contains the $i - 1$ closest nodes to s
- 2 Want to find the i th closest node from $V - X$.
- 1 For each $u \in V - X$ let $P(s, u, X)$ be a shortest path from s to u using only nodes in X as intermediate vertices.
- 2 Let $d'(s, u)$ be the length of $P(s, u, X)$

Observations: for each $u \in V - X$,

- 1 $\text{dist}(s, u) \leq d'(s, u)$ since we are constraining the paths
- 2 $d'(s, u) = \min_{t \in X} (\text{dist}(s, t) + \ell(t, u))$ - Why?

Lemma (d' has the right value for i th vertex)

If v is the i th closest node to s , then $d'(s, v) = \text{dist}(s, v)$.

Finding the i th closest node

- 1 X contains the $i - 1$ closest nodes to s
- 2 Want to find the i th closest node from $V - X$.
- 1 For each $u \in V - X$ let $P(s, u, X)$ be a shortest path from s to u using only nodes in X as intermediate vertices.
- 2 Let $d'(s, u)$ be the length of $P(s, u, X)$

Observations: for each $u \in V - X$,

- 1 $\text{dist}(s, u) \leq d'(s, u)$ since we are constraining the paths
- 2 $d'(s, u) = \min_{t \in X} (\text{dist}(s, t) + \ell(t, u))$ - Why?

Lemma (d' has the right value for i th vertex)

If v is the i th closest node to s , then $d'(s, v) = \text{dist}(s, v)$.

Finding the i th closest node

Lemma (d' has the right value for i th vertex)

Given:

- 1 X : Set of $i - 1$ closest nodes to s .
- 2 $d'(s, u) = \min_{t \in X} (\text{dist}(s, t) + \ell(t, u))$

If v is an i th closest node to s , then $d'(s, v) = \text{dist}(s, v)$.

Proof.

Let v be the i th closest node to s . Then there is a shortest path P from s to v that contains only nodes in X as intermediate nodes (see previous claim). Therefore $d'(s, v) = \text{dist}(s, v)$. □

Finding the i th closest node

Lemma (d' has the right value for i th vertex)

If v is an i th closest node to s , then $d'(s, v) = \text{dist}(s, v)$.

Corollary

The i th closest node to s is the node $v \in V - X$ such that $d'(s, v) = \min_{u \in V - X} d'(s, u)$.

Proof.

For every node $u \in V - X$, $\text{dist}(s, u) \leq d'(s, u)$ and for the i th closest node v , $\text{dist}(s, v) = d'(s, v)$. Moreover, $\text{dist}(s, u) \geq \text{dist}(s, v)$ for each $u \in V - X$. \square

Algorithm

```
Initialize for each node  $v$ :  $\text{dist}(s, v) = \infty$ 
Initialize  $X = \emptyset$ ,  $d'(s, s) = 0$ 
for  $i = 1$  to  $|V|$  do
    (* Invariant:  $X$  contains the  $i - 1$  closest nodes to  $s$  *)
    (* Invariant:  $d'(s, u)$  is shortest path distance from  $u$  to  $s$ 
    using only  $X$  as intermediate nodes*)
    Let  $v$  be such that  $d'(s, v) = \min_{u \in V - X} d'(s, u)$ 
     $\text{dist}(s, v) = d'(s, v)$ 
     $X = X \cup \{v\}$ 
    for each node  $u$  in  $V - X$  do
         $d'(s, u) = \min_{t \in X} (\text{dist}(s, t) + \ell(t, u))$ 
```

Correctness: By induction on i using previous lemmas.

Running time: $O(n \cdot (n + m))$ time.

- ① n outer iterations. In each iteration, $d'(s, u)$ for each u by scanning all edges out of nodes in X ; $O(m + n)$ time/iteration.

Algorithm

```
Initialize for each node  $v$ :  $\text{dist}(s, v) = \infty$   
Initialize  $X = \emptyset$ ,  $d'(s, s) = 0$   
for  $i = 1$  to  $|V|$  do  
    (* Invariant:  $X$  contains the  $i - 1$  closest nodes to  $s$  *)  
    (* Invariant:  $d'(s, u)$  is shortest path distance from  $u$  to  $s$   
    using only  $X$  as intermediate nodes*)  
    Let  $v$  be such that  $d'(s, v) = \min_{u \in V - X} d'(s, u)$   
     $\text{dist}(s, v) = d'(s, v)$   
     $X = X \cup \{v\}$   
    for each node  $u$  in  $V - X$  do  
         $d'(s, u) = \min_{t \in X} (\text{dist}(s, t) + \ell(t, u))$ 
```

Correctness: By induction on i using previous lemmas.

Running time: $O(n \cdot (n + m))$ time.

- ① n outer iterations. In each iteration, $d'(s, u)$ for each u by scanning all edges out of nodes in X ; $O(m + n)$ time/iteration.

Algorithm

```
Initialize for each node  $v$ :  $\text{dist}(s, v) = \infty$   
Initialize  $X = \emptyset$ ,  $d'(s, s) = 0$   
for  $i = 1$  to  $|V|$  do  
    (* Invariant:  $X$  contains the  $i - 1$  closest nodes to  $s$  *)  
    (* Invariant:  $d'(s, u)$  is shortest path distance from  $u$  to  $s$   
    using only  $X$  as intermediate nodes*)  
    Let  $v$  be such that  $d'(s, v) = \min_{u \in V - X} d'(s, u)$   
     $\text{dist}(s, v) = d'(s, v)$   
     $X = X \cup \{v\}$   
    for each node  $u$  in  $V - X$  do  
         $d'(s, u) = \min_{t \in X} (\text{dist}(s, t) + \ell(t, u))$ 
```

Correctness: By induction on i using previous lemmas.

Running time: $O(n \cdot (n + m))$ time.

- ① n outer iterations. In each iteration, $d'(s, u)$ for each u by scanning all edges out of nodes in X ; $O(m + n)$ time/iteration.

Algorithm

```
Initialize for each node  $v$ :  $\text{dist}(s, v) = \infty$   
Initialize  $X = \emptyset$ ,  $d'(s, s) = 0$   
for  $i = 1$  to  $|V|$  do  
    (* Invariant:  $X$  contains the  $i - 1$  closest nodes to  $s$  *)  
    (* Invariant:  $d'(s, u)$  is shortest path distance from  $u$  to  $s$   
    using only  $X$  as intermediate nodes*)  
    Let  $v$  be such that  $d'(s, v) = \min_{u \in V - X} d'(s, u)$   
     $\text{dist}(s, v) = d'(s, v)$   
     $X = X \cup \{v\}$   
    for each node  $u$  in  $V - X$  do  
         $d'(s, u) = \min_{t \in X} (\text{dist}(s, t) + \ell(t, u))$ 
```

Correctness: By induction on i using previous lemmas.

Running time: $O(n \cdot (n + m))$ time.

- ① n outer iterations. In each iteration, $d'(s, u)$ for each u by scanning all edges out of nodes in X ; $O(m + n)$ time/iteration.

THE END

...

(for now)

17.3.7

Dijkstra's algorithm

Example: Dijkstra algorithm in action

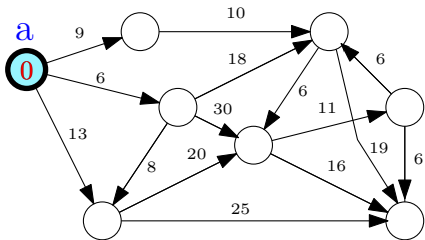

Example: Dijkstra algorithm in action

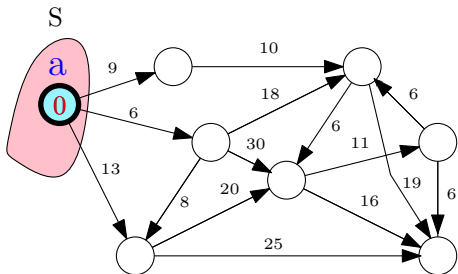

Example: Dijkstra algorithm in action

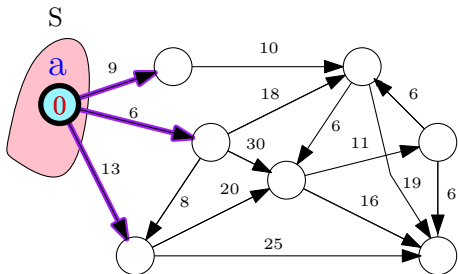

Example: Dijkstra algorithm in action

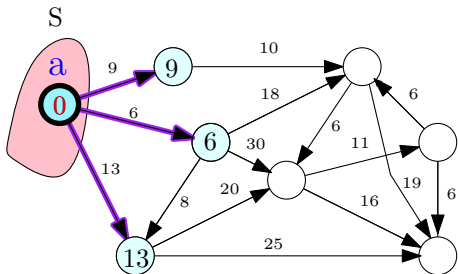

Example: Dijkstra algorithm in action

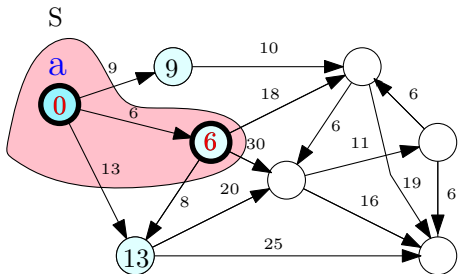

Example: Dijkstra algorithm in action

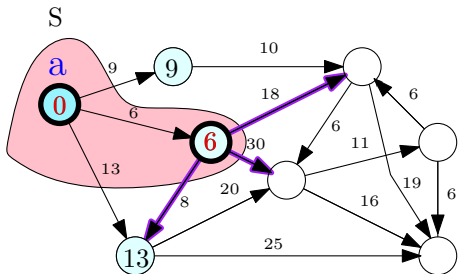

Example: Dijkstra algorithm in action

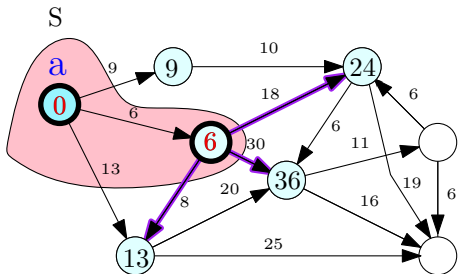

Example: Dijkstra algorithm in action

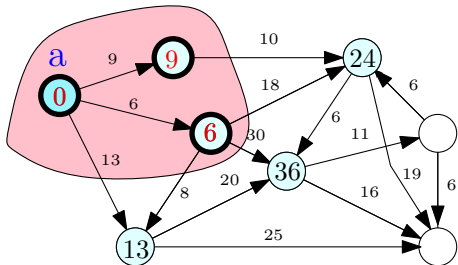

Example: Dijkstra algorithm in action

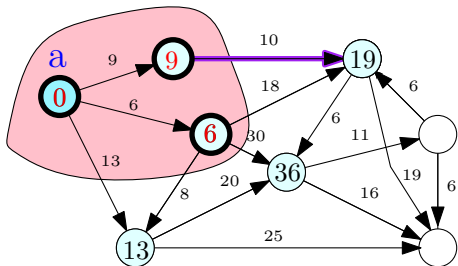

Example: Dijkstra algorithm in action

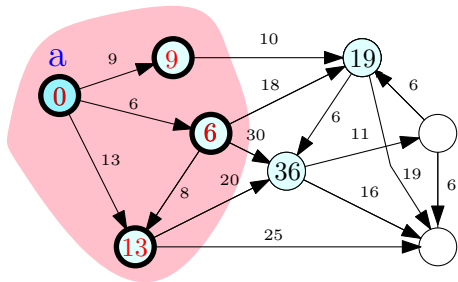

Example: Dijkstra algorithm in action

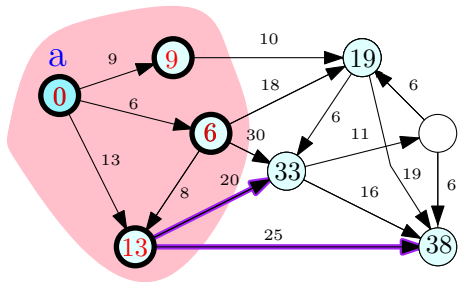

Example: Dijkstra algorithm in action

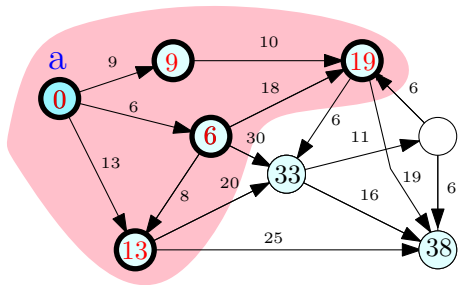

Example: Dijkstra algorithm in action

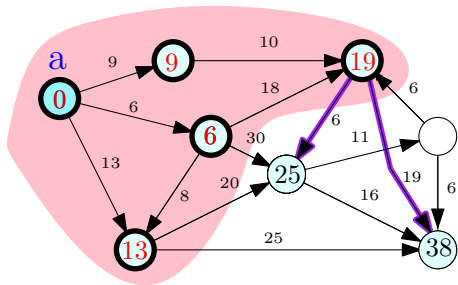

Example: Dijkstra algorithm in action

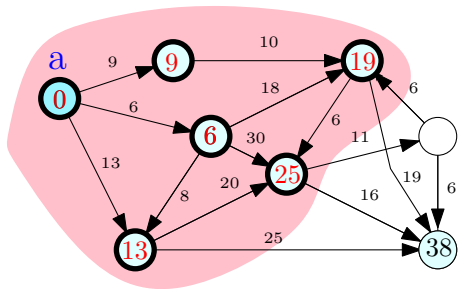

Example: Dijkstra algorithm in action

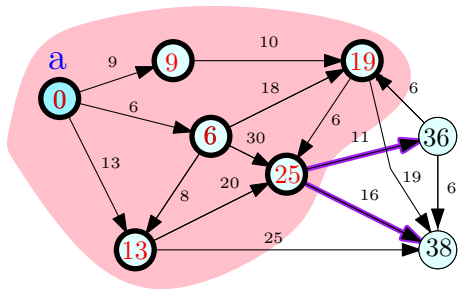

Example: Dijkstra algorithm in action

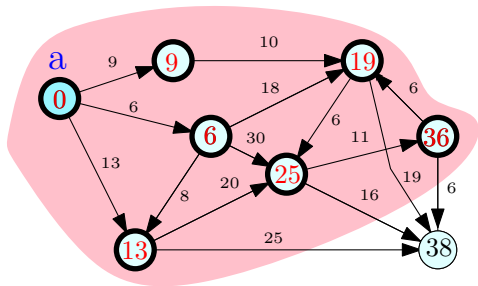

Example: Dijkstra algorithm in action

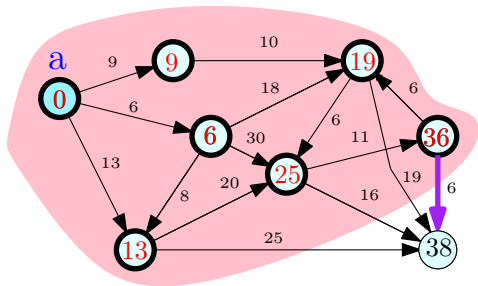

Example: Dijkstra algorithm in action

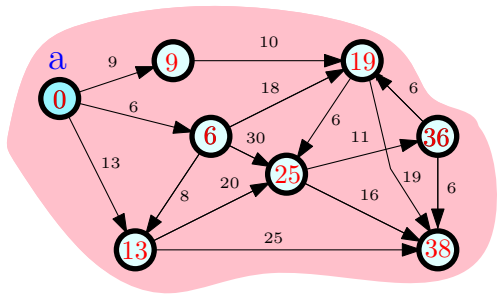

Improved Algorithm

- 1 Main work is to compute the $d'(s, u)$ values in each iteration
- 2 $d'(s, u)$ changes from iteration i to $i + 1$ only because of the node v that is added to X in iteration i .

```
Initialize for each node  $v$ ,  $\text{dist}(s, v) = d'(s, v) = \infty$   
Initialize  $X = \emptyset$ ,  $d'(s, s) = 0$   
for  $i = 1$  to  $|V|$  do  
    //  $X$  contains the  $i - 1$  closest nodes to  $s$ ,  
    // and the values of  $d'(s, u)$  are current  
    Let  $v$  be node realizing  $d'(s, v) = \min_{u \in V - X} d'(s, u)$   
     $\text{dist}(s, v) = d'(s, v)$   
     $X = X \cup \{v\}$   
    Update  $d'(s, u)$  for each  $u$  in  $V - X$  as follows:  
         $d'(s, u) = \min(d'(s, u), \text{dist}(s, v) + \ell(v, u))$ 
```

Running time: $O(m + n^2)$ time.

- 1 n outer iterations and in each iteration following steps
- 2 updating $d'(s, u)$ after v is added takes $O(\text{deg}(v))$ time so total work is $O(m)$

Improved Algorithm

- 1 Main work is to compute the $d'(s, u)$ values in each iteration
- 2 $d'(s, u)$ changes from iteration i to $i + 1$ only because of the node v that is added to X in iteration i .

```
Initialize for each node  $v$ ,  $\text{dist}(s, v) = d'(s, v) = \infty$   
Initialize  $X = \emptyset$ ,  $d'(s, s) = 0$   
for  $i = 1$  to  $|V|$  do  
    //  $X$  contains the  $i - 1$  closest nodes to  $s$ ,  
    // and the values of  $d'(s, u)$  are current  
    Let  $v$  be node realizing  $d'(s, v) = \min_{u \in V - X} d'(s, u)$   
     $\text{dist}(s, v) = d'(s, v)$   
     $X = X \cup \{v\}$   
    Update  $d'(s, u)$  for each  $u$  in  $V - X$  as follows:  
         $d'(s, u) = \min(d'(s, u), \text{dist}(s, v) + \ell(v, u))$ 
```

Running time: $O(m + n^2)$ time.

- 1 n outer iterations and in each iteration following steps
- 2 updating $d'(s, u)$ after v is added takes $O(\text{deg}(v))$ time so total work is $O(m)$

Improved Algorithm

```
Initialize for each node  $v$ ,  $\text{dist}(s, v) = d'(s, v) = \infty$   
Initialize  $X = \emptyset$ ,  $d'(s, s) = 0$   
for  $i = 1$  to  $|V|$  do  
    //  $X$  contains the  $i - 1$  closest nodes to  $s$ ,  
    // and the values of  $d'(s, u)$  are current  
    Let  $v$  be node realizing  $d'(s, v) = \min_{u \in V - X} d'(s, u)$   
     $\text{dist}(s, v) = d'(s, v)$   
     $X = X \cup \{v\}$   
    Update  $d'(s, u)$  for each  $u$  in  $V - X$  as follows:  
         $d'(s, u) = \min(d'(s, u), \text{dist}(s, v) + \ell(v, u))$ 
```

Running time: $O(m + n^2)$ time.

- 1 n outer iterations and in each iteration following steps
- 2 updating $d'(s, u)$ after v is added takes $O(\text{deg}(v))$ time so total work is $O(m)$ since a node enters X only once
- 3 Finding v from $d'(s, u)$ values is $O(n)$ time

Dijkstra's Algorithm

- 1 eliminate $d'(s, u)$ and let $\text{dist}(s, u)$ maintain it
- 2 update dist values after adding v by scanning edges out of v

```
Initialize for each node  $v$ ,  $\text{dist}(s, v) = \infty$   
Initialize  $X = \emptyset$ ,  $\text{dist}(s, s) = 0$   
for  $i = 1$  to  $|V|$  do  
  Let  $v$  be such that  $\text{dist}(s, v) = \min_{u \in V-X} \text{dist}(s, u)$   
   $X = X \cup \{v\}$   
  for each  $u$  in  $\text{Adj}(v)$  do  
     $\text{dist}(s, u) = \min(\text{dist}(s, u), \text{dist}(s, v) + \ell(v, u))$ 
```

Priority Queues to maintain dist values for faster running time

- 1 Using heaps and standard priority queues: $O((m + n) \log n)$
- 2 Using Fibonacci heaps: $O(m + n \log n)$.

Dijkstra's Algorithm

- 1 eliminate $d'(s, u)$ and let $\text{dist}(s, u)$ maintain it
- 2 update dist values after adding v by scanning edges out of v

```
Initialize for each node  $v$ ,  $\text{dist}(s, v) = \infty$   
Initialize  $X = \emptyset$ ,  $\text{dist}(s, s) = 0$   
for  $i = 1$  to  $|V|$  do  
  Let  $v$  be such that  $\text{dist}(s, v) = \min_{u \in V - X} \text{dist}(s, u)$   
   $X = X \cup \{v\}$   
  for each  $u$  in  $\text{Adj}(v)$  do  
     $\text{dist}(s, u) = \min(\text{dist}(s, u), \text{dist}(s, v) + \ell(v, u))$ 
```

Priority Queues to maintain dist values for faster running time

- 1 Using heaps and standard priority queues: $O((m + n) \log n)$
- 2 Using Fibonacci heaps: $O(m + n \log n)$.

THE END

...

(for now)

17.3.8

Dijkstra using priority queues

Priority Queues

Data structure to store a set S of n elements where each element $v \in S$ has an associated real/integer key $k(v)$ such that the following operations:

- 1 **makePQ**: create an empty queue.
- 2 **findMin**: find the minimum key in S .
- 3 **extractMin**: Remove $v \in S$ with smallest key and return it.
- 4 **insert**($v, k(v)$): Add new element v with key $k(v)$ to S .
- 5 **delete**(v): Remove element v from S .
- 6 **decreaseKey**($v, k'(v)$): decrease key of v from $k(v)$ (current key) to $k'(v)$ (new key). Assumption: $k'(v) \leq k(v)$.
- 7 **meld**: merge two separate priority queues into one.

All operations can be performed in $O(\log n)$ time.

decreaseKey is implemented via **delete** and **insert**.

Priority Queues

Data structure to store a set S of n elements where each element $v \in S$ has an associated real/integer key $k(v)$ such that the following operations:

- 1 **makePQ**: create an empty queue.
- 2 **findMin**: find the minimum key in S .
- 3 **extractMin**: Remove $v \in S$ with smallest key and return it.
- 4 **insert**($v, k(v)$): Add new element v with key $k(v)$ to S .
- 5 **delete**(v): Remove element v from S .
- 6 **decreaseKey**($v, k'(v)$): decrease key of v from $k(v)$ (current key) to $k'(v)$ (new key). Assumption: $k'(v) \leq k(v)$.
- 7 **meld**: merge two separate priority queues into one.

All operations can be performed in $O(\log n)$ time.

decreaseKey is implemented via **delete** and **insert**.

Priority Queues

Data structure to store a set S of n elements where each element $v \in S$ has an associated real/integer key $k(v)$ such that the following operations:

- 1 **makePQ**: create an empty queue.
- 2 **findMin**: find the minimum key in S .
- 3 **extractMin**: Remove $v \in S$ with smallest key and return it.
- 4 **insert**($v, k(v)$): Add new element v with key $k(v)$ to S .
- 5 **delete**(v): Remove element v from S .
- 6 **decreaseKey**($v, k'(v)$): decrease key of v from $k(v)$ (current key) to $k'(v)$ (new key). Assumption: $k'(v) \leq k(v)$.
- 7 **meld**: merge two separate priority queues into one.

All operations can be performed in $O(\log n)$ time.

decreaseKey is implemented via **delete** and **insert**.

Dijkstra's Algorithm using Priority Queues

```
 $Q \leftarrow \text{makePQ}()$   
 $\text{insert}(Q, (s, 0))$   
for each node  $u \neq s$  do  
     $\text{insert}(Q, (u, \infty))$   
 $X \leftarrow \emptyset$   
for  $i = 1$  to  $|V|$  do  
     $(v, \text{dist}(s, v)) = \text{extractMin}(Q)$   
     $X = X \cup \{v\}$   
    for each  $u$  in  $\text{Adj}(v)$  do  
         $\text{decreaseKey}(Q, (u, \min(\text{dist}(s, u), \text{dist}(s, v) + \ell(v, u))))$ .
```

Priority Queue operations:

- 1 $O(n)$ **insert** operations
- 2 $O(n)$ **extractMin** operations
- 3 $O(m)$ **decreaseKey** operations

Implementing Priority Queues via Heaps

Using Heaps

Store elements in a heap based on the key value

- 1 All operations can be done in $O(\log n)$ time

Dijkstra's algorithm can be implemented in $O((n + m) \log n)$ time.

Implementing Priority Queues via Heaps

Using Heaps

Store elements in a heap based on the key value

- 1 All operations can be done in $O(\log n)$ time

Dijkstra's algorithm can be implemented in $O((n + m) \log n)$ time.

Priority Queues: Fibonacci Heaps/Relaxed Heaps

Fibonacci Heaps

- ① **extractMin**, **insert**, **delete**, **meld** in $O(\log n)$ time
- ② **decreaseKey** in $O(1)$ amortized time: ℓ **decreaseKey** operations for $\ell \geq n$ take together $O(\ell)$ time
- ③ Relaxed Heaps: **decreaseKey** in $O(1)$ worst case time but at the expense of **meld** (not necessary for Dijkstra's algorithm)

- ① Dijkstra's algorithm can be implemented in $O(n \log n + m)$ time. If $m = \Omega(n \log n)$, running time is linear in input size.
- ② Data structures are complicated to analyze/implement. Recent work has obtained data structures that are easier to analyze and implement, and perform well in practice. Rank-Pairing Heaps, for example.
- ③ Boost library implements both Fibonacci heaps and rank-pairing heaps.

Priority Queues: Fibonacci Heaps/Relaxed Heaps

Fibonacci Heaps

- 1 **extractMin**, **insert**, **delete**, **meld** in $O(\log n)$ time
- 2 **decreaseKey** in $O(1)$ amortized time: ℓ **decreaseKey** operations for $\ell \geq n$ take together $O(\ell)$ time
- 3 Relaxed Heaps: **decreaseKey** in $O(1)$ worst case time but at the expense of **meld** (not necessary for Dijkstra's algorithm)

- 1 Dijkstra's algorithm can be implemented in $O(n \log n + m)$ time. If $m = \Omega(n \log n)$, running time is linear in input size.
- 2 Data structures are complicated to analyze/implement. Recent work has obtained data structures that are easier to analyze and implement, and perform well in practice. Rank-Pairing Heaps, for example.
- 3 Boost library implements both Fibonacci heaps and rank-pairing heaps.

Priority Queues: Fibonacci Heaps/Relaxed Heaps

Fibonacci Heaps

- 1 **extractMin**, **insert**, **delete**, **meld** in $O(\log n)$ time
 - 2 **decreaseKey** in $O(1)$ amortized time: ℓ **decreaseKey** operations for $\ell \geq n$ take together $O(\ell)$ time
 - 3 Relaxed Heaps: **decreaseKey** in $O(1)$ worst case time but at the expense of **meld** (not necessary for Dijkstra's algorithm)
-
- 1 Dijkstra's algorithm can be implemented in $O(n \log n + m)$ time. If $m = \Omega(n \log n)$, running time is linear in input size.
 - 2 Data structures are complicated to analyze/implement. Recent work has obtained data structures that are easier to analyze and implement, and perform well in practice. Rank-Pairing Heaps, for example.
 - 3 Boost library implements both Fibonacci heaps and rank-pairing heaps.

Priority Queues: Fibonacci Heaps/Relaxed Heaps

Fibonacci Heaps

- 1 **extractMin**, **insert**, **delete**, **meld** in $O(\log n)$ time
 - 2 **decreaseKey** in $O(1)$ amortized time: ℓ **decreaseKey** operations for $\ell \geq n$ take together $O(\ell)$ time
 - 3 Relaxed Heaps: **decreaseKey** in $O(1)$ worst case time but at the expense of **meld** (not necessary for Dijkstra's algorithm)
-
- 1 Dijkstra's algorithm can be implemented in $O(n \log n + m)$ time. If $m = \Omega(n \log n)$, running time is linear in input size.
 - 2 Data structures are complicated to analyze/implement. Recent work has obtained data structures that are easier to analyze and implement, and perform well in practice. Rank-Pairing Heaps, for example.
 - 3 Boost library implements both Fibonacci heaps and rank-pairing heaps.

THE END

...

(for now)

17.4

Shortest path trees and variants

Algorithms & Models of Computation

CS/ECE 374, Fall 2020

17.4.1

Shortest Path Tree

Shortest Path Tree

Dijkstra's algorithm finds the shortest path distances from s to V .

Question: How do we find the paths themselves?

```
Q = makePQ()
insert(Q, (s, 0))
prev(s) ← null
for each node  $u \neq s$  do
    insert(Q, (u,  $\infty$ ))
    prev(u) ← null

X =  $\emptyset$ 
for  $i = 1$  to  $|V|$  do
    ( $v$ ,  $\text{dist}(s, v)$ ) = extractMin(Q)
    X = X  $\cup$  { $v$ }
    for each  $u$  in Adj( $v$ ) do
        if ( $\text{dist}(s, v) + \ell(v, u) < \text{dist}(s, u)$ ) then
            decreaseKey(Q, ( $u$ ,  $\text{dist}(s, v) + \ell(v, u)$ ))
            prev(u) =  $v$ 
```

Shortest Path Tree

Dijkstra's algorithm finds the shortest path distances from s to V .

Question: How do we find the paths themselves?

```
Q = makePQ()
insert(Q, (s, 0))
prev(s) ← null
for each node u ≠ s do
    insert(Q, (u, ∞) )
    prev(u) ← null

X = ∅
for i = 1 to |V| do
    (v, dist(s, v)) = extractMin(Q)
    X = X ∪ {v}
    for each u in Adj(v) do
        if (dist(s, v) + ℓ(v, u) < dist(s, u)) then
            decreaseKey(Q, (u, dist(s, v) + ℓ(v, u)))
            prev(u) = v
```

Shortest Path Tree

Lemma

The edge set $(u, \text{prev}(u))$ is the reverse of a shortest path tree rooted at s . For each u , the reverse of the path from u to s in the tree is a shortest path from s to u .

Proof Sketch.

- 1 The edge set $\{(u, \text{prev}(u)) \mid u \in V\}$ induces a directed in-tree rooted at s (Why?)
- 2 Use induction on $|X|$ to argue that the tree is a shortest path tree for nodes in V .



Shortest paths to s

Dijkstra's algorithm gives shortest paths from s to all nodes in V .

How do we find shortest paths from all of V to s ?

- 1 In undirected graphs shortest path from s to u is a shortest path from u to s so there is no need to distinguish.
- 2 In directed graphs, use Dijkstra's algorithm in G^{rev} !

Shortest paths to s

Dijkstra's algorithm gives shortest paths from s to all nodes in V .

How do we find shortest paths from all of V to s ?

- 1 In undirected graphs shortest path from s to u is a shortest path from u to s so there is no need to distinguish.
- 2 In directed graphs, use Dijkstra's algorithm in G^{rev} !

THE END

...

(for now)

17.4.2

Variants on the shortest path problem

Shortest paths between sets of nodes

Suppose we are given $S \subset V$ and $T \subset V$. Want to find shortest path from S to T defined as:

$$\mathbf{dist}(S, T) = \min_{s \in S, t \in T} \mathbf{dist}(s, t)$$

How do we find $\mathbf{dist}(S, T)$?

Example Problem

You want to go from your house to a friend's house. Need to pick up some dessert along the way and hence need to stop at one of the many potential stores along the way. How do you calculate the “shortest” trip if you include this stop?

Given $G = (V, E)$ and edge lengths $\ell(e), e \in E$. Want to go from s to t . A subset $X \subset V$ that corresponds to stores. Want to find $\min_{x \in X} d(s, x) + d(x, t)$.

Basic solution: Compute for each $x \in X$, $d(s, x)$ and $d(x, t)$ and take minimum. $2|X|$ shortest path computations. $O(|X|(m + n \log n))$.

Better solution: Compute shortest path distances from s to every node $v \in V$ with one Dijkstra. Compute from every node $v \in V$ shortest path distance to t with one Dijkstra.

Example Problem

You want to go from your house to a friend's house. Need to pick up some dessert along the way and hence need to stop at one of the many potential stores along the way. How do you calculate the "shortest" trip if you include this stop?

Given $G = (V, E)$ and edge lengths $\ell(e), e \in E$. Want to go from s to t . A subset $X \subset V$ that corresponds to stores. Want to find $\min_{x \in X} d(s, x) + d(x, t)$.

Basic solution: Compute for each $x \in X$, $d(s, x)$ and $d(x, t)$ and take minimum. $2|X|$ shortest path computations. $O(|X|(m + n \log n))$.

Better solution: Compute shortest path distances from s to every node $v \in V$ with one Dijkstra. Compute from every node $v \in V$ shortest path distance to t with one Dijkstra.

Example Problem

You want to go from your house to a friend's house. Need to pick up some dessert along the way and hence need to stop at one of the many potential stores along the way. How do you calculate the "shortest" trip if you include this stop?

Given $G = (V, E)$ and edge lengths $\ell(e), e \in E$. Want to go from s to t . A subset $X \subset V$ that corresponds to stores. Want to find $\min_{x \in X} d(s, x) + d(x, t)$.

Basic solution: Compute for each $x \in X$, $d(s, x)$ and $d(x, t)$ and take minimum. $2|X|$ shortest path computations. $O(|X|(m + n \log n))$.

Better solution: Compute shortest path distances from s to every node $v \in V$ with one Dijkstra. Compute from every node $v \in V$ shortest path distance to t with one Dijkstra.

Example Problem

You want to go from your house to a friend's house. Need to pick up some dessert along the way and hence need to stop at one of the many potential stores along the way. How do you calculate the "shortest" trip if you include this stop?

Given $G = (V, E)$ and edge lengths $\ell(e), e \in E$. Want to go from s to t . A subset $X \subset V$ that corresponds to stores. Want to find $\min_{x \in X} d(s, x) + d(x, t)$.

Basic solution: Compute for each $x \in X$, $d(s, x)$ and $d(x, t)$ and take minimum. $2|X|$ shortest path computations. $O(|X|(m + n \log n))$.

Better solution: Compute shortest path distances from s to every node $v \in V$ with one Dijkstra. Compute from every node $v \in V$ shortest path distance to t with one Dijkstra.

THE END

...

(for now)